

RESOL DeltaSol[®] ES

Mounting

Connection

Handling

Fault localization

Examples



48000820

Thanks for buying a RESOL.

Read this manual carefully to get the best performance from this unit.

DeltaSol[®] ES



manual

www.resol.com

Contents

Imprint	2	2.2	System monitoring display	22
Security devices	2	2.2.1	Channel indication.....	22
Technical data and function survey	3	2.2.2	Tool bar	22
1. Installation	4	2.2.3	System screen.....	23
1.1 Mounting.....	4	2.3	Blinking codes.....	23
1.2 Electrical wiring.....	4	2.3.1	System screen blinking codes.....	23
1.2.1 Connection survey.....	4	2.3.2	LED blinking codes.....	23
1.2.2 Actuators.....	5	3. Commissioning	24	
1.2.3 Bus.....	5	4. Control parameter and indication channels	25	
1.2.4 Sensors.....	6	4.1 Channel overview.....	25	
1.2.5 Power connection.....	6	4.2.1-7 Indication channels	31	
1.3 Allocation of terminals	7	4.3.1-15 Adjustment channels.....	32	
1.3.1-30 Systems 1-30.....	7	5. Tips for fault localization	37	
2 Operation and function	22	5.1 Miscellaneous.....	38	
2.1 Adjustment buttons	22	6. Accessory	40	

Safety regulations:

Please read the following information carefully before installing and operating the controller. In this way damage to the solar system by wrong installation will be avoided. Please observe that the mounting is adapted to the characteristics of the building, that the local regulations are respected and is conform with the technical rules.

DIN 4757, part 1

Solar heating systems with water and water mixtures as heat transfer medium; Demands to the safety realization.

DIN 4757, part 2

Solar heating systems with organic heat transfer medium; Demands to safety realization.

DIN 4757, part 3

Solar heating systems; solar collectors; Meanings; safety regulations; Testing of standstill temperature

DIN 4757, part 4

Solar thermal systems; solar collectors; determination of efficiency, heat capacity and pressure loss.

In addition to that European standards are worked out:

EN 12975-1

Thermal solar systems and their components; collectors, part 1: General demands.

EN 12975-2

Thermal solar systems and their components; collectors; part 2: Test processes

EN 12976-1

Thermal solar systems and their components; prefabricated systems, part 1: General demands.

EN 12976-2

Thermal solar systems and their components; prefabricated systems, part 2: Test processes

EN 12977-1

Thermal solar systems and their components; Customer-designed manufactured systems, part 1: General demands.

EN 12977-2

Thermal solar systems and their components; Customer-designed manufactured systems, part 2: Test processes

EN 12977-3

Thermal solar systems and their components; Customer-designed manufactured systems, part 3: Performance test of warm water tanks.

Imprint:

This mounting- and operation manual including all parts is copyrighted. Another use outside the copyright requires the approval of RESOL - Elektronische Regelungen GmbH. This especially applies for copies, translations, micro films and the storage into electronic systems.

Editor: RESOL - Elektronische Regelungen GmbH

Important notice:

We took a lot of care over the texts and drawings of this manual and to the best of our knowledge and consent. As faults can never be excluded, please note: Your own calculations and plans under consideration of the current norms and DIN-directions should only be basis for your projects. We don't offer a guarantee for the completeness of the drawings and texts of this manual - they only represent some examples. They can only be used on own risk. No liability is assumed for incorrect, incomplete or false information and the resulting damages.

Errors and technical changes excepted.

- 36 basic solar systems selectable
- illuminated system-monitoring display
- pump speed control, solar operating hours counter and heat quantity measurement
- 10 sensor inputs
- 6 relay outputs
- function control
- RESOLVBus®

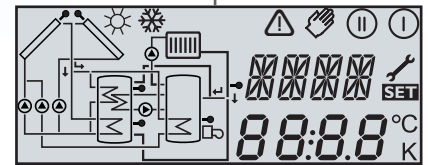

Scope of delivery:

- 1 x DeltaSol® ES
- 1 x accessory bag
 - 2 x screws and dowels
 - 4 x strain-relief and screws
 - 1 x condenser 4,7 nF

Additionally enclosed in the full kit:

- 2 x sensor FKP6
- 3 x sensor FRP6

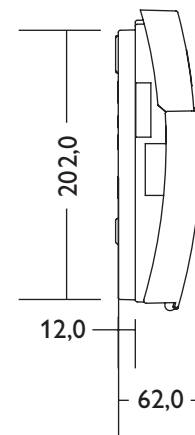
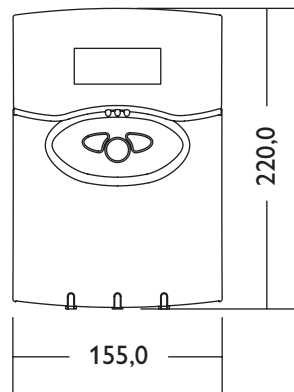

Technical data

Housing: plastic, PC-ABS and PMMA

Protection type:
IP 20 / DIN 40 050

Environmental-temp.: 0...40 °C

Size: 220 x 155 x 62 mm

Mounting: wall mounting, mounting into patch-panels is possible

Display: multi-functional combined display with illuminated background, stored system sketches and pictograms, a 4-digit alpha-numerical 16-segment display and a 4-digit numerical 7-segment display as well as a 2 coloured LED. The controller can be equipped optionally with an illuminated 4-digit LC-text display.

Operation: by 3 pushbuttons in the front of the housing

Functions: solar- and heating controller with pre-programmed and selectable system schemes, just as: standard solar system, 2-tank systems, east-/west collectors, heating circuit back-up, heat exchange regulation, thermostatic after-heating, solid hot fuel boilers, add-on functions and options just as heat quantity measurement, collector cooling function, tube collector special function, anti-freeze function, minimum temperature limitation, pump speed control, balancing of heat quantity output, function control according to BAW-guidelines.

Sensor inputs: 10 sensor inputs for Pt1000, CS10, V40

Relay outputs: 6 relay outputs, 3 of them for pump speed control

Bus: RESOLVBus®

Power supply: 115V~

Breaking capacity:
4 (1)A (115) V~

Dimensioning surge voltage:
2,5 kV

Effectiveness: Typ 1.b / Typ 1.y

Degree of pollution 2



Electrostatic discharge can cause damages of electronic components



Attention: high-voltaged components

1. Installation

1.1 Mounting

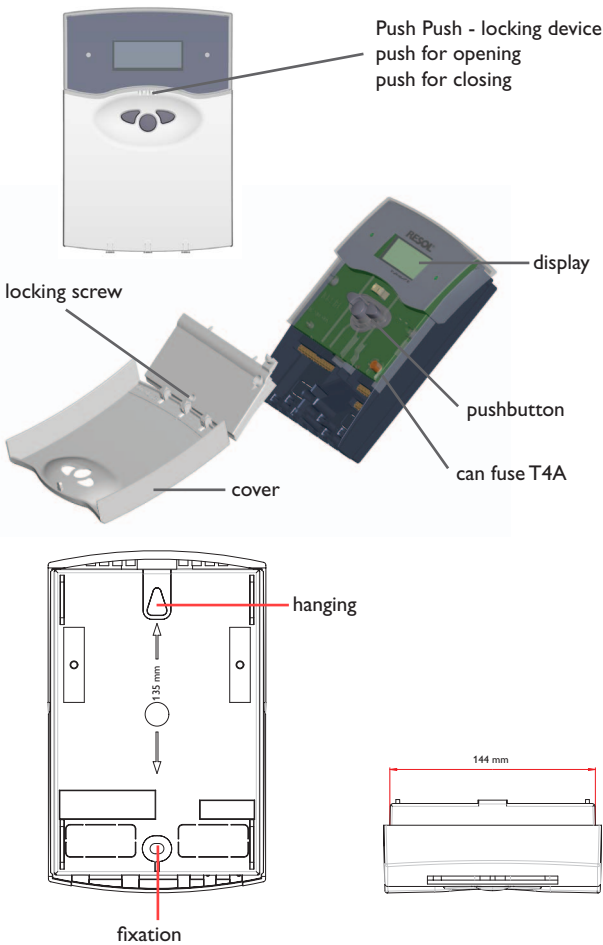

Warning!
Switch-off power supply before opening the housing.

The unit has to be located internally. It is not suitable for installation in hazardous locations and should not be sited near to any electromagnetic fields. The controller must additionally be equipped with an all-polar gap of at least 3 mm or with a gap according to the valid installation regulations, e.g. LS-switches or fuses. Please pay attention to a separate laying of the sensor lines and the AC power supply.

1. Unscrew the cross-recessed screw of the cover and remove it from the housing.
2. Mark the upper fastening point on the underground and premount the enclosed dowel and screw.
3. Hang up the housing at the upper fastening point and mark the lower fastening point on the underground (hole pitch 135 mm), afterwards put the lower dowel.
4. Fasten the housing at the underground.
5. Connection is to be effected according to terminal allocation.
6. The housing is to be closed properly.

1.2 Electrical connection

1.2.1 Survey of electrical connections

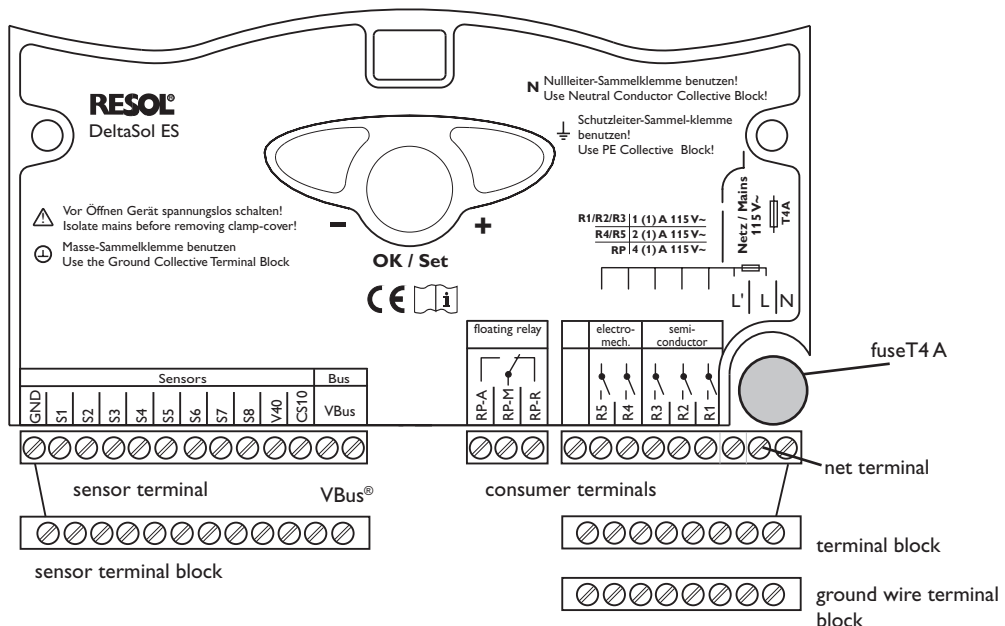

1.2.2 Actuators

(pumps, valves, etc.)

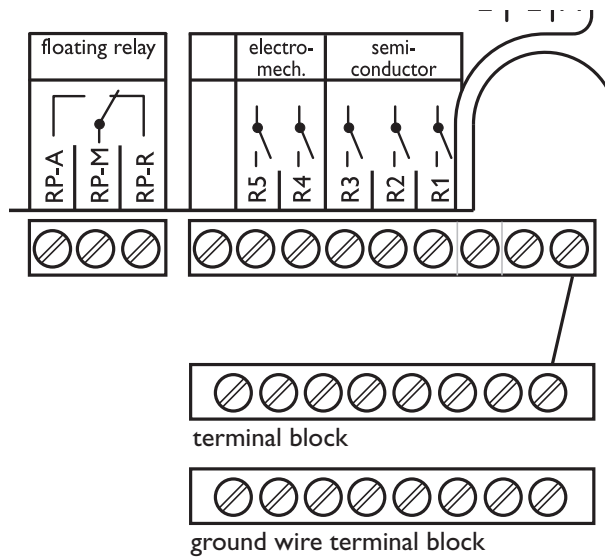

The controller is equipped with 6 relays totally, to which the **consumers** (actuators), just as pumps, valves and auxiliary relays are to be connected:

- **The relays R1 ...R3** are semi-conductor relays, appropriated for pump speed control as well:
 - R1 ...R3 = normally open contact R1 ...R3
 - N = neutral conductor N (terminal block)
 - PE = ground wire PE (terminal block)
- **The relays R4 and R5** are electro-mechanic relays with 1 shutter:
 - R4, R5 = normally open contacts R4, R5
 - N = neutral conductor N (terminal block)
 - PE = ground wire PE (terminal block)
- **The relay RP** is a potential-free relay with change-over-contact:
 - RP-M = middle contact RP
 - RP-A = normally open contact RP
 - RP-R = break contact RP

RP switches parallel to R3 in all systems with afterheating (SYS 3, 10, 12, 15, 19, 22, 25, 28) to provide a boiler demand if necessary.

Please note:

the relays R1 up to R3 are designed for pump speed control as semi-conductor relays. They need a minimum load of 20W (power consumption of the consumer) for perfect functioning. In case that auxiliary relays, motor valves, etc. are connected, the enclosed condensor must be parallelly connected to the corresponding relay output.

Attention: in case that auxiliary relays or valves are connected, the minimum pump speed is to be adjusted to 100 %.

1.2.3 Data communication / Bus

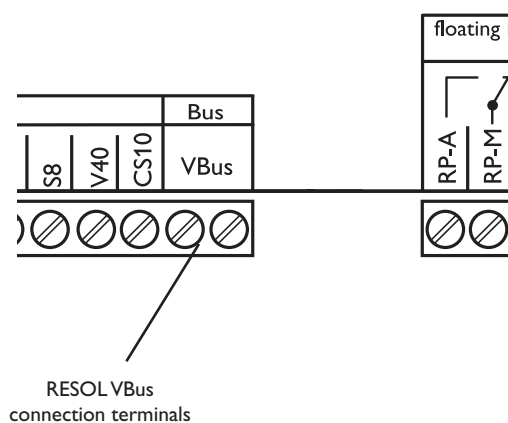

The controller is equipped with the RESOL **VBus**® for data communication with or without power supply of external modules. Connection is effected without any polarity to both terminals marked „VBus“. One or more RESOL VBus modules can be connected by this data-bus, e.g.:

- RESOL WMZ-M1, calorimeter module
- RESOL large displays
- RESOL data logger

1.2.4 Sensors

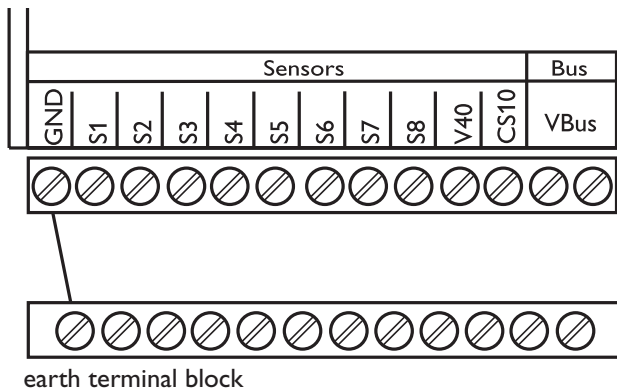

The controller is totally equipped with 10 sensor inputs. The earth connection for sensors is effected by the earth terminal block (GND).

- The **temperature sensors** are connected to the terminals S1 ...S8 and GND regardless of the polarity.
- A **flowmeter** RESOLV40 can be connectd to the terminals V40 and GND regardless of the polarity.
- The **irradiation sensor (CS10)** is to be connected to the terminals CS10 and GND with respect to polarity. Connect the terminal GND of the sensor to the terminal GND of the controller, and the terminal CS of the sensor to the terminal CS10 of the controller.

1.2.5 Power connection

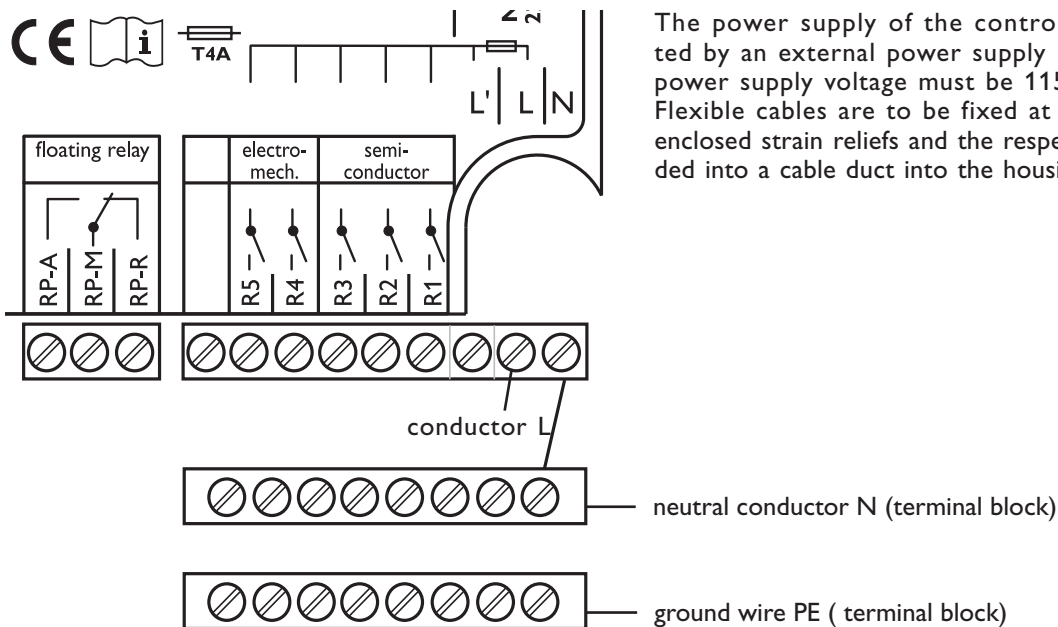

The power supply of the controller must be effected by an external power supply (last step!) and the power supply voltage must be 115 Volt (50 ...60 Hz). Flexible cables are to be fixed at the housing by the enclosed strain reliefs and the respective screws or leaded into a cable duct into the housing of the controller.

2. Operation and function

2.1 Pushbuttons for adjustment

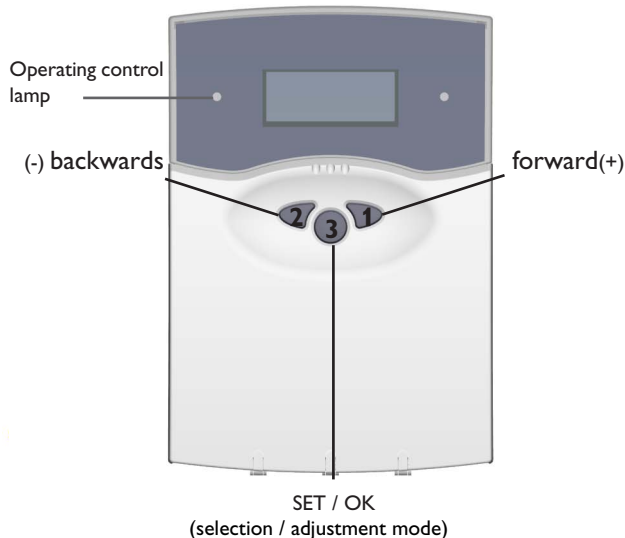

The controller is operated by 3 pushbuttons below the display. The forward-key (1) is used for scrolling forward through the indication menu or to increase the adjustment values. The backwards-key (2) is accordingly used for the reverse function.

For adjustment of last indication channel, keep button 1 pressed for 2 seconds. If an **adjustment value** is shown on the display, **SEt** is indicated. In this case you can press the key „Set“ (3) in order to change into input mode.

Select a channel by keys 1 and 2
Shortly press key 3, so that „SEt“ flashes
Adjust the value by keys 1 and 2
Shortly press key 3, so that „SEt“ permanently appears, the adjusted value is now saved.

2.2 System-Monitoring-Display

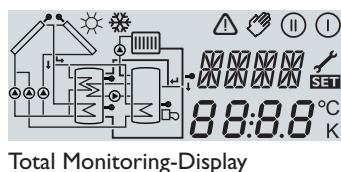

The system monitoring display consists of 3 blocks:
indication of the channel, tool bar and **system screen** (active system scheme).

2.2.1 Channel indication

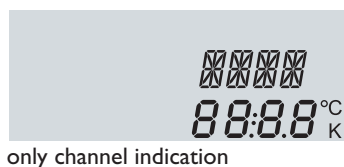

The **indication channel** consists of two lines. The upper line is an alphanumeric 16-segment indication, in which mainly the channel names / menu items are shown. In the lower 7-segment indication, the channel values and the adjustment parameter are indicated. Temperatures and temperature differences are indicated in °C or K.

2.2.2 Tool bar



The additional symbols of the **tool bar** indicate the current system status.

Symbol	normal	flashing
ⓘ	Relais 1 activated	
Ⓜ	Relais 2 activated	
☀	Tank maximum limitation activated / tank maximum temperature exceeded	Collector cooling function activated Recooling function activated
❄	Option antifreeze activated	Collector minimum function activated Antifreeze function activated
⚠		Collector emergency shutdown activated or tank shutdown
⚠ + 🔧		Sensor defect
⚠ + 🧤		Manual operation
SEt	At adjustment mode	An adjustment channel is changed SET-Modus

2.2.3 System-Screen

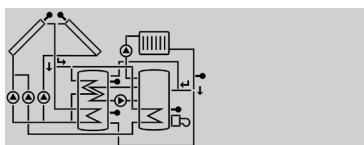

only system screen

The system screen (active system scheme) shows the schemes selected on the controller. It consists of several system component symbols, which are - depending on the current status of the system - either flashing, permanently shown or hidden.

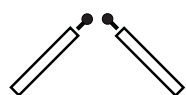
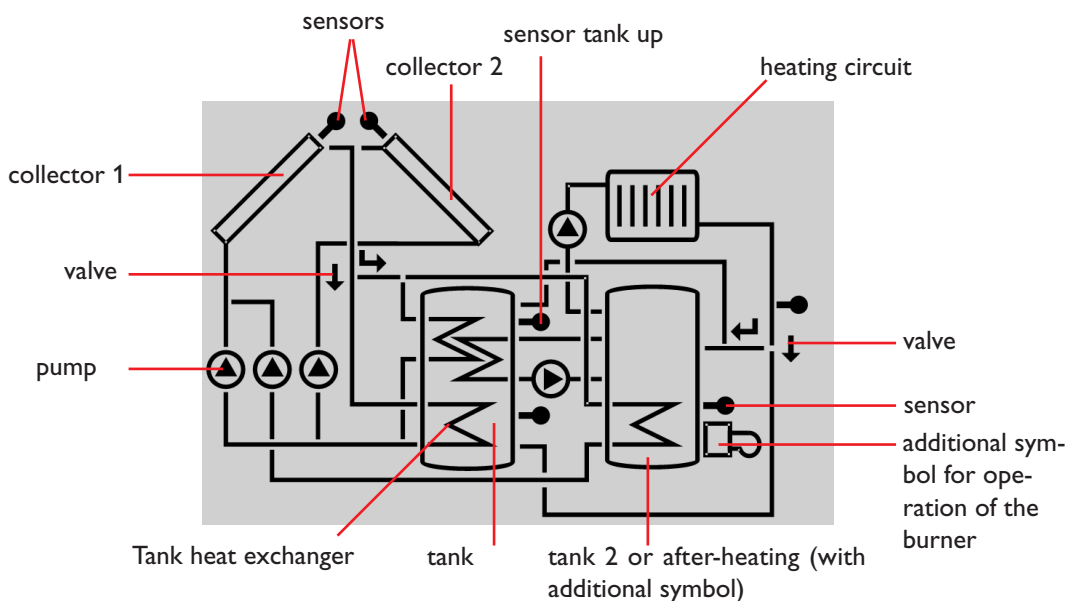

Collectors
wit collector sensor



Temperature sensor

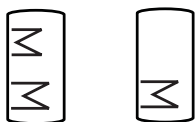

Tank 1 and 2
with heat exchanger



Heating circuit



Pump



3-way-valve
Just the current flow direction respectively the circuit direction is shown.



After-heating
with burner symbol

2.3 Blinking codes

2.3.1 System-Screen blinking codes

- Pumps are blinking during starting phase
- Sensors are blinking if the respective sensor indication channel is selected.
- Sensors are blinking quickly in case of sensor defect.
- Burner symbol is blinking if after-heating is activated.

2.3.2 LED blinking codes

- Constantly green: everything alright
manual operation
- Red blinking: Sensor defect
(sensor symbol is quickly blinking)

3. Commissioning

On commissioning you have to adjust primarily the system scheme!

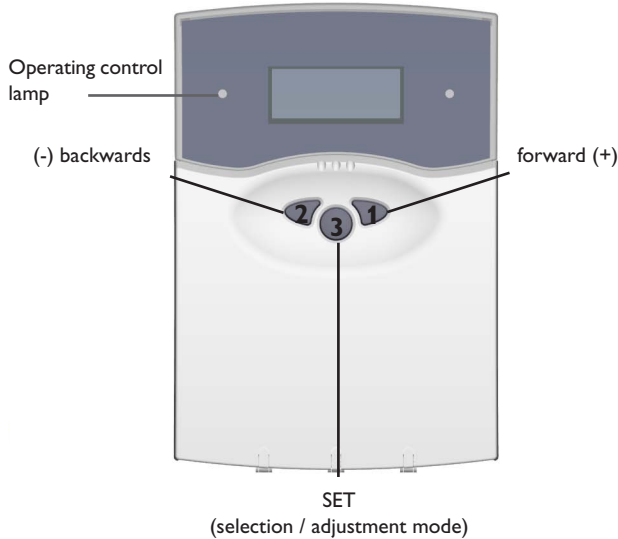

1. Ac power supply must be activated. The controller passes an initialisation phase in which the operating control lamp flashes red and green. After having finished the initialisation, the controller is in automatic operation (factory settings). The preadjusted system scheme is Arr 1.

2. Adjust the time in the adjustment channel **TIME**. By pressing once the pushbutton **SET** the hours are shown (blinking), by pressing again the minutes are shown (blinking). The time can be adjusted by pushbuttons 1 and 2 and be stored by a last pressing of the pushbutton **SET**.

3. - Select **Arr**

- change into **SET**-mode (see 2.1)
- Select system scheme by Arr-characteristics
- Adjustments are stored by pressing **SET**

4. If the solar sensor CS10 is used

- change into **SET**-mode (see 2.1)
- select **CS10** type by characteristics
- adjustments are stored by pressing **SET**

Now the controller is ready for operation and should enable an optimum operation of the solar system.

PLEASE NOTE:

System status is resetto factory settings by modification of the system!

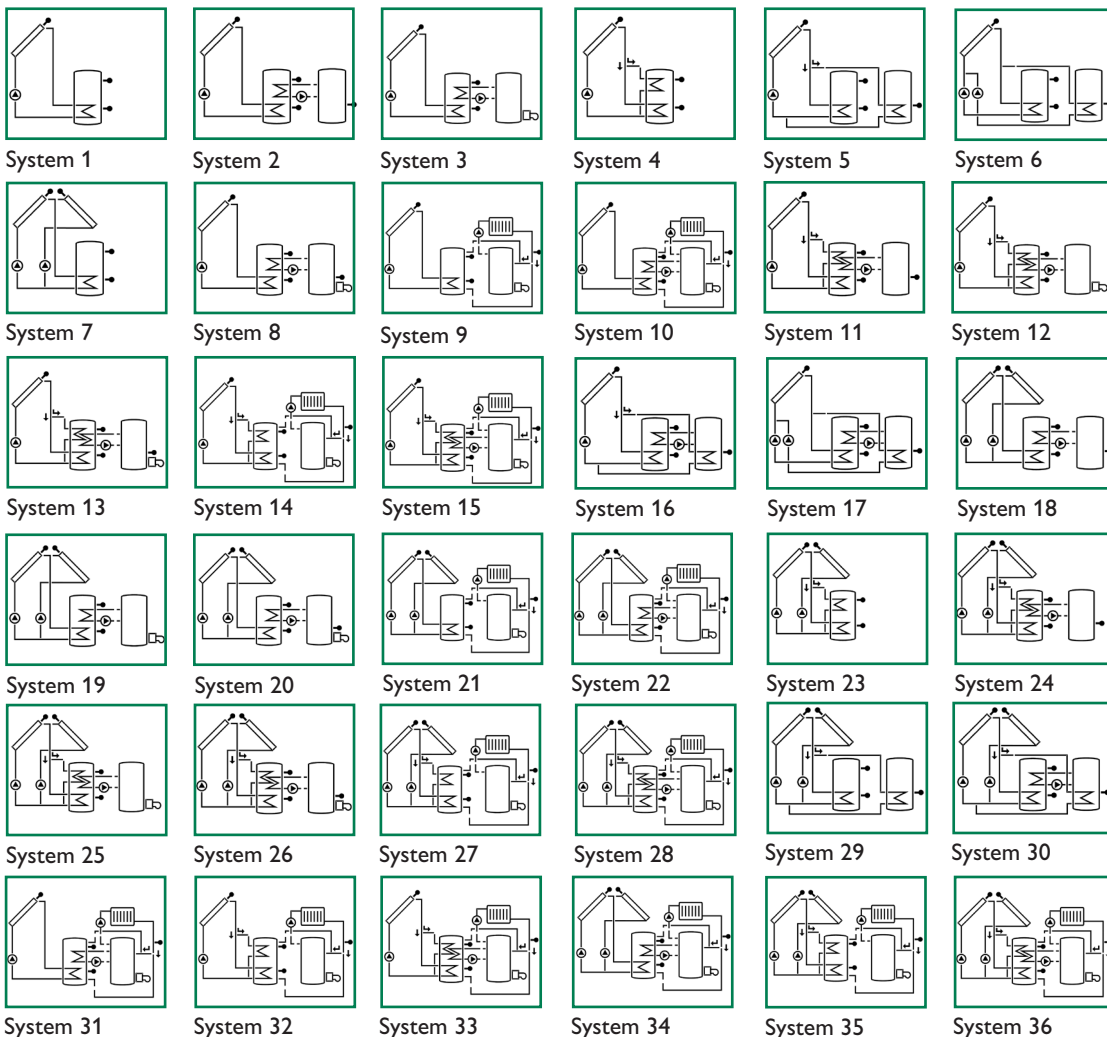

4. Controller parameter and adjustment channels

4.1 Channel overview

Legend:

x

Corresponding channel is available.

x*

Corresponding channel is available if the appropriate option is activated.

①

Corresponding channel is only available if the option heat quantity measurement is **activated** (OHQM).

MEDT

The channel antifreeze function (MED%) is only shown if there is **not used water or Tyfocor LS / G-LS (MEDT 0 or 3)**. The adjustment of the content of antifreeze does only make sense when using antifreeze components in the solar circuit.

Please note:

S3 and S4 are only indicated in case of sensors connected (shown)

Channel survey: Systems Arr 1...10

Channel	Arr										Description	Page
	1	2	3	4	5	6	7	8	9	10		
COL	x	x	x	x	x	x		x	x	x	Collector temperature 1	18
COL 1							x				Collector temperature 1	18
TSTL	x		x	x			x	x	x	x	Tank temperature lower	18
TST1		x			x	x					Tank temperature 1 lower	18
TSTU	x	x	x	x	x	x	x	x	x	x	Tank temperature 1 at the top	18
S4											Tank temperature at the middle	18
TST2		x			x	x					Tank temperature 2 lower	18
TFSB								x			Temperature solid fuel boiler	18
TRET									x	x	Temperature heating circuit	18
COL2							x				Collector temperature 2	18
TFL	①	①	①	①	①	①	①	①	①	①	Temperature flow sensor	18
TRF	①	①	①	①	①	①	①	①	①	①	Temperature return sensor	18
IRR	x	x	x	x	x	x	x	x	x	x	Solar irradiation intensity	18
n %	x			x	x				x		Pump speed Relais	18
n1 %		x	x			x	x	x		x	Pump speed Relais 1	18
n2 %						x	x				Pump speed Relais 2	18
n3%		x	x					x		x	Pump speed Relais 3	18
hP	x			x	x				x		Hours of operation relais 1	18
h P1		x	x			x	x	x		x	Hours of operation relais 1	18
h P2						x	x				Hours of operation relais 2	18
h P3		x	x					x		x	Hours of operation relais 3	18
FLOW	①	①	①	①	①	①	①	①	①	①	Volume flow	19
kWh	①	①	①	①	①	①	①	①	①	①	Heat quantity kWh	19
MWh	①	①	①	①	①	①	①	①	①	①	Heat quantity MWh	19
TIME	x										Time	19
Arr	1-36										System	9
DT O	x	x	x				x	x	x	x	Switch-on temperature difference	20
DT1O				x	x	x					Switch-on temperature difference 1	20
DT F	x	x	x				x	x	x	x	Switch-off temperature difference 1	20
DT1F				x	x	x					Switch-off temperature difference 1	20
DT S	x	x	x				x	x	x	x	Set temperature difference	20
DT1S				x	x	x					Set temperature difference 1	20
RIS	x	x	x				x	x	x	x	Rise	20
RIS1				x	x	x					Rise 1	20
S MX	x	x	x				x	x	x	x	Maximum tank temperature 1	20
S1 MX				x	x	x					Maximum tank temperature 1	20
DT2O				x	x	x					Switch-on temperature difference 2	20
DT2F				x	x	x					Set temperature difference 2	20
DT2S				x	x	x					Set temperature difference 2	20
RIS2				x	x	x					Rise 2	20
S2MX				x	x	x					Maximum tank temperature 2	20
EM	x	x	x	x	x	x		x	x	x	Emergency collector temperatur 1	21
EM1							x				Emergency collector temperatur 1	21

Chan- nel	Arr										Description	Page
	1	2	3	4	5	6	7	8	9	10		
OCX	x	x	x	x	x	x		x	x	x	Option Collector cooling collector 1	21
OCX1								x			Option Collector cooling collector 1	21
CMX	x*	x*	x*	x*	x*	x*		x*	x*	x*	Maximum collector temperature 1	21
CMX1								x*			Maximum collector temperature 1	21
OCN	x	x	x	x	x	x		x	x	x	Option min. limitation collector 1	21
OCN1								x			Option min. limitation collector 1	21
CMN	x*	x*	x*	x*	x*	x*		x*	x*		Minimum temperature collector 1	21
CMN1								x*			Minimum temperature collector 1	21
OCF	x	x	x	x	x	x		x	x	x	Option antifreeze collector 1	21
OCF1								x			Option antifreeze collector 1	21
CFR	x*	x*	x*	x*	x*	x*		x*	x*	x*	Antifreeze temperature collector 1	21
CFR1								x*			Antifreeze temperature collector1	21
EM2								x			Emergency temperature collector 2	21
OCX2								x			Option collector cooling collector 2	21
CMX2								x*			Maximum temperatur collector 2	21
OCN2								x			Option min. limitation collector 2	21
CMN2								x*			Minimum temperature collector 2	21
OCF2								x			Option antifreeze collector 2	21
CFR2								x*			Antifreeze temperature collector 2	21
PRIO				x	x	x					Priority	22
tSP				x	x	x					Stop time	22
tRUN				x	x	x					Circulation	22
OREC	x	x	x	x	x	x	x	x	x	x	Option recooling	22
OTC	x	x	x	x	x	x	x	x	x	x	Option tube collector	22
DT3O		x						x		x	Switch-on temperature difference 3	20
DT3F		x						x		x	Switch-off temperature difference 3	20
DT3S		x						x			Set temperature DT3	20
RIS3		x						x			Rise DT3	20
MX3O		x						x			Switch-on step max. temperature	20
MX3F		x						x			Switch-off step max. temperature	20
MN3O		x						x			Switch-on step min. temperature	20
MN3F		x						x			Switch-off step min. temperature	20
AH O			x							x	Switch-on temperature thermostat	23
AH F			x							x	Switch-off temperature thermostat	23
t1 E			x							x	Switch-on time 1 thermostat	23
t1 A			x							x	Switch-off time 1 thermostat	23
t2 E			x							x	Switch-on time 2 thermostat	23
t2 A			x							x	Switch-off time 2 thermostat	23
t3 E			x							x	Switch-on time 3 thermostat	23
t3 A			x							x	Switch-off time 3 thermostat	23
OHQM	x	x	x	x	x	x	x	x	x	x	Option HQM	19
VIMP	①	①	①	①	①	①	①	①	①	①	Impulse rate volume flow counter	19
MEDT	①	①	①	①	①	①	①	①	①	①	Antifreeze	19
MED %	MEDT	MEDT	MEDT	MEDT	MEDT	MEDT	MEDT	MEDT	MEDT	MEDT	Antifreeze concentration	19
CS 10	x	x	x	x	x	x	x	x	x	x	Solar cell	19
n MN	x			x	x					x	Minimum pump speed relais 1	23
n1MN		x	x			x	x				Minimum pump speed relais 1	23
n2MN						x	x				Minimum pump speed relais 2	23
n3MN		x						x			Minimum pump speed relais 3	23
MAN1	x	x	x	x	x	x	x	x	x	x	Manual operation relais 1	23
MAN2	x	x	x	x	x	x	x	x	x	x	Manual operation relais 2	23
MAN3	x	x	x	x	x	x	x	x	x	x	Manual operation relais 3	23
MAN4	x	x	x	x	x	x	x	x	x	x	Manual operation relais 4	23
MAN5	x	x	x	x	x	x	x	x	x	x	Manual operation relais 5	23
MAN6	x	x	x	x	x	x	x	x	x	x	Manual operation relais 6	23
LANG	x	x	x	x	x	x	x	x	x	x	Language	23
PROG	XX.XX										Programme version	
VERS	X.XX										Version	

Channel survey: Systems Arr 11 ...20

Channel	Arr										Description	Page
	11	12	13	14	15	16	17	18	19	20		
COL	x	x	x	x	x	x	x				Collector temperature 1	18
COL 1								x	x	x	Collector temperature 1	18
TSTL		x	x	x	x				x	x	Tank temperature lower	18
TST1	x										Tank temperature 1 lower	18
TSTU	x	x	x	x	x	x	x	x	x	x	Tank temperature 1 at the top	18
S4											Tank temperature at the middle	18
TST2	x					x	x	x			Tank temperature 2 lower	18
TFSB			x							x	Temperature solid fuel boiler	18
TRET				x	x						Temperature heating circuit	18
COL2								x	x	x	Collector temperature 2	18
TFL	⊕	⊕	⊕	⊕	⊕	⊕	⊕	⊕	⊕	⊕	Temperature flow sensor	18
TRF	⊕	⊕	⊕	⊕	⊕	⊕	⊕	⊕	⊕	⊕	Temperature return sensor	18
IRR	x	x	x	x	x	x	x	x	x	x	Solar irradiation intensity	18
n %				x							Pump speed Relais	18
n1 %	x	x	x		x	x	x	x	x	x	Pump speed Relais 1	18
n2 %							x	x	x	x	Pump speed Relais 2	18
n3%	x	x	x		x	x	x	x	x	x	Pump speed Relais 3	18
hP				x							Hours of operation relais 1	18
h P1	x	x	x		x	x	x	x	x	x	Hours of operation relais 1	18
h P2							x	x	x	x	Hours of operation relais 2	18
h P3	x	x	x		x	x	x	x	x	x	Hours of operation relais 3	18
FLOW	⊕	⊕	⊕	⊕	⊕	⊕	⊕	⊕	⊕	⊕	Volume flow	19
kWh	⊕	⊕	⊕	⊕	⊕	⊕	⊕	⊕	⊕	⊕	Heat quantity kWh	19
MWh	⊕	⊕	⊕	⊕	⊕	⊕	⊕	⊕	⊕	⊕	Heat quantity MWh	19
TIME	x										Time	19
Arr	1-36										System	9
DT O								x	x	x	Switch-on temperature difference	20
DT1O	x	x	x	x	x	x	x				Switch-on temperature difference 1	20
DT F								x	x	x	Switch-off temperature difference 1	20
DT1F	x	x	x	x	x	x	x				Switch-off temperature difference 1	20
DT S								x	x	x	Set temperature difference	20
DT1S	x	x	x	x	x	x	x				Set temperature difference 1	20
RIS								x	x	x	Rise	20
RIS1	x	x	x	x	x	x	x				Rise 1	20
S MX								x	x	x	Maximum tank temperature 1	20
S1 MX	x	x	x	x	x	x	x				Maximum tank temperature 1	20
DT2O	x	x	x	x	x	x	x				Switch-on temperature difference 2	20
DT2F	x	x	x	x	x	x	x				Set temperature difference 2	20
DT2S	x	x	x	x	x	x	x				Set temperature difference 2	20
RIS2	x	x	x	x	x	x	x				Rise 2	20
S2MX	x	x	x	x	x	x	x				Maximum tank temperature 2	20
EM	x	x	x	x	x	x	x				Emergency collector temperatur 1	21
EM1								x	x	x	Emergency collector temperatur 1	21

Chan- nel	Arr										Description	Page
	11	12	13	14	15	16	17	18	19	20		
OCX	x	x	x	x	x	x	x				Option Collector cooling collector 1	21
OCX1								x	x	x	Option Collector cooling collector 1	21
CMX	x*	x*	x*	x*	x*	x*	x*				Maximum collector temperature 1	21
CMX1								x*	x*	x*	Maximum collector temperature 1	21
OCN	x	x	x	x	x	x	x				Option min. limitation collector 1	21
OCN1								x	x	x	Option min. limitation collector 1	21
CMN	x*	x*	x*	x*	x*	x*	x*				Minimum temperature collector 1	21
CMN1								x*	x*	x*	Minimum temperature collector 1	21
OCF	x	x	x	x	x	x	x				Option antifreeze collector 1	21
OCF1								x	x	x	Option antifreeze collector 1	21
CFR	x*	x*	x*	x*	x*	x*	x*				Antifreeze temperature collector 1	21
CFR1								x*	x*	x*	Antifreeze temperature collector1	21
EM2								x	x	x	Emergency temperature collector 2	21
OCX2								x	x	x	Option collector cooling collector 2	21
CMX2								x*	x*	x*	Maximum temperatur collector 2	21
OCN2								x	x	x	Option min. limitation collector 2	21
CMN2								x*	x*	x*	Minimum temperature collector 2	21
OCF2								x	x	x	Option antifreeze collector 2	21
CFR2								x*	x*	x*	Antifreeze temperature collector 2	21
PRIO	x	x	x	x	x	x	x				Priority	22
tSP	x	x	x	x	x	x	x				Stop time	22
tRUN	x	x	x	x	x	x	x				Circulation	22
OREC	x	x	x	x	x	x	x	x	x	x	Option recooling	22
OTC	x	x	x	x	x	x	x	x	x	x	Option tube collector	22
DT3O	x		x	x	x	x	x	x			Switch-on temperature difference 3	20
DT3F	x		x	x	x	x	x	x			Switch-off temperature difference 3	20
DT3S	x		x			x	x	x			Set temperature DT3	20
RIS3	x		x			x	x	x			Rise DT3	20
MX3O	x		x			x	x	x			Switch-on step max. temperature	20
MX3F	x		x			x	x	x			Switch-off step max. temperature	20
MN3O	x		x			x	x	x			Switch-on step min. temperature	20
MN3F	x		x			x	x	x			Switch-off step min. temperature	20
AH O		x			x					x	Switch-on temperature thermostat	23
AH F		x			x					x	Switch-off temperature thermostat	23
t1 E		x			x					x	Switch-on time 1 thermostat	23
t1 A		x			x					x	Switch-off time 1 thermostat	23
t2 E		x			x					x	Switch-on time 2 thermostat	23
t2 A		x			x					x	Switch-off time 2 thermostat	23
t3 E		x			x					x	Switch-on time 3 thermostat	23
t3 A		x			x					x	Switch-off time 3 thermostat	23
OHQM	x	x	x	x	x	x	x	x	x	x	Option HQM	19
VIMP	①	①	①	①	①	①	①	①	①	①	Impulse rate volume flow counter	19
MEDT	①	①	①	①	①	①	①	①	①	①	Antifreeze	19
MED %	MEDT	MEDT	MEDT	MEDT	MEDT	MEDT	MEDT	MEDT	MEDT	MEDT	Antifreeze concentration	19
CS 10	x	x	x	x	x	x	x	x	x	x	Solar cell	19
n MN				x							Minimum pump speed relais 1	23
n1MN	x	x	x		x	x	x	x	x	x	Minimum pump speed relais 1	23
n2MN							x	x	x	x	Minimum pump speed relais 2	23
n3MN	x		x			x	x	x	x	x	Minimum pump speed relais 3	23
MAN1	x	x	x	x	x	x	x	x	x	x	Manual operation relais 1	23
MAN2	x	x	x	x	x	x	x	x	x	x	Manual operation relais 2	23
MAN3	x	x	x	x	x	x	x	x	x	x	Manual operation relais 3	23
MAN4	x	x	x	x	x	x	x	x	x	x	Manual operation relais 4	23
MAN5	x	x	x	x	x	x	x	x	x	x	Manual operation relais 5	23
MAN6	x	x	x	x	x	x	x	x	x	x	Manual operation relais 6	23
LANG	x	x	x	x	x	x	x	x	x	x	Language	23
PROG	XX.XX										Programme version	
VERS	X.XX										Version	

Channel survey: Systems Arr 21 ...30

Chan- nel	Arr										Description	Page
	21	22	23	24	25	26	27	28	29	30		
COL											Collector temperature 1	18
COL 1	x	x	x	x	x	x	x	x	x	x	Collector temperature 1	18
TSTL	x	x	x		x	x	x	x			Tank temperature lower	18
TST1									x	x	Tank temperature 1 lower	18
TSTU	x	x	x	x	x	x	x	x	x	x	Tank temperature 1 at the top	18
S4											Tank temperature at the middle	18
TST2									x	x	Tank temperature 2 lower	18
TFSB						x					Temperature solid fuel boiler	18
TRET	x	x					x	x			Temperature heating circuit	18
COL2	x	x	x	x	x	x	x	x	x	x	Collector temperature 2	18
TFL	⊕	⊕	⊕	⊕	⊕	⊕	⊕	⊕	⊕	⊕	Temperature flow sensor	18
TRF	⊕	⊕	⊕	⊕	⊕	⊕	⊕	⊕	⊕	⊕	Temperature return sensor	18
IRR	x	x	x	x	x	x	x	x	x	x	Solar irradiation intensity	18
n %											Pump speed Relais	18
n1 %	x	x	x	x	x	x	x	x	x	x	Pump speed Relais 1	18
n2 %	x	x	x	x	x	x	x	x	x	x	Pump speed Relais 2	18
n3%		x		x	x	x		x		x	Pump speed Relais 3	18
hP											Hours of operation relais 1	18
h P1	x	x	x	x	x	x	x	x	x	x	Hours of operation relais 1	18
h P2	x	x	x	x	x	x	x	x	x	x	Hours of operation relais 2	18
h P3	x	x		x	x	x		x		x	Hours of operation relais 3	18
FLOW	⊕	⊕	⊕	⊕	⊕	⊕	⊕	⊕	⊕	⊕	Volume flow	19
kWh	⊕	⊕	⊕	⊕	⊕	⊕	⊕	⊕	⊕	⊕	Heat quantity kWh	19
MWh	⊕	⊕	⊕	⊕	⊕	⊕	⊕	⊕	⊕	⊕	Heat quantity MWh	19
TIME	x										Time	19
Arr	1-36										System	9
DT O	x	x									Switch-on temperature difference	20
DT1O			x	x	x	x	x	x	x	x	Switch-on temperature difference 1	20
DT F	x	x									Switch-off temperature difference 1	20
DT1F			x	x	x	x	x	x	x	x	Switch-off temperature difference 1	20
DT S	x	x									Set temperature difference	20
DT1S			x	x	x	x	x	x	x	x	Set temperature difference 1	20
RIS	x	x									Rise	20
RIS1			x	x	x	x	x	x	x	x	Rise 1	20
S MX	x	x							x		Maximum tank temperature 1	20
S1 MX			x	x	x	x	x	x	x	x	Maximum tank temperature 1	20
DT2O			x	x	x	x	x	x	x	x	Switch-on temperature difference 2	20
DT2F			x	x	x	x	x	x	x	x	Set temperature difference 2	20
DT2S			x	x	x	x	x	x	x	x	Set temperature difference 2	20
RIS2			x	x	x	x	x	x	x	x	Rise 2	20
S2MX			x	x	x	x	x	x	x	x	Maximum tank temperature 2	20
EM											Emergency collector temperatur 1	21
EM1	x	x	x	x	x	x	x	x	x	x	Emergency collector temperatur 1	21

Chan- nel	Arr										Description	Page
	21	22	23	24	25	26	27	28	29	30		
OCX											Option Collector cooling collector 1	21
OCX1	x	x	x	x	x	x	x	x	x	x	Option Collector cooling collector 1	21
CMX											Maximum collector temperature 1	21
CMX1	x*	x*	x*	x*	x*	x*	x*	x*	x*	x*	Maximum collector temperature 1	21
OCN											Option min. limitation collector 1	21
OCN1	x	x	x	x	x	x	x	x	x	x	Option min. limitation collector 1	21
CMN											Minimum temperature collector 1	21
CMN1	x*	x*	x*	x*	x*	x*	x*	x*	x*	x*	Minimum temperature collector 1	21
OCF											Option antifreeze collector 1	21
OCF1	x	x	x	x	x	x	x	x	x	x	Option antifreeze collector 1	21
CFR											Antifreeze temperature collector 1	21
CFR1	x*	x*	x*	x*	x*	x*	x*	x*	x*	x*	Antifreeze temperature collector1	21
EM2	x	x	x	x	x	x	x	x	x	x	Emergency temperature collector 2	21
OCX2	x	x	x	x	x	x	x	x	x	x	Option collector cooling collector 2	21
CMX2	x*	x*	x*	x*	x*	x*	x*	x*	x*	x*	Maximum temperatur collector 2	21
OCN2	x	x	x	x	x	x	x	x	x	x	Option min. limitation collector 2	21
CMN2	x*	x*	x*	x*	x*	x*	x*	x*	x*	x*	Minimum temperature collector 2	21
OCF2	x	x	x	x	x	x	x	x	x	x	Option antifreeze collector 2	21
CFR2	x*	x*	x*	x*	x*	x*	x*	x*	x*	x*	Antifreeze temperature collector 2	21
PRIO			x	x	x	x	x	x	x	x	Priority	22
tSP			x	x	x	x	x	x	x	x	Stop time	22
tRUN			x	x	x	x	x	x	x	x	Circulation	22
OREC	x	x	x	x	x	x	x	x	x	x	Option recooling	22
OTC	x	x	x	x	x	x	x	x	x	x	Option tube collector	22
DT3O	x	x		x		x	x	x			Switch-on temperature difference 3	20
DT3F	x	x		x		x	x	x		x	Switch-off temperature difference 3	20
DT3S				x		x				x	Set temperature DT3	20
RIS3				x		x				x	Rise DT3	20
MX3O				x		x				x	Switch-on step max. temperature	20
MX3F				x		x				x	Switch-off step max. temperature	20
MN3O				x		x				x	Switch-on step min. temperature	20
MN3F				x		x				x	Switch-off step min. temperature	20
AH O		x			x			x			Switch-on temperature thermostat	23
AH F		x			x			x			Switch-off temperature thermostat	23
t1 E		x			x			x			Switch-on time 1 thermostat	23
t1 A		x			x			x			Switch-off time 1 thermostat	23
t2 E		x			x			x			Switch-on time 2 thermostat	23
t2 A		x			x			x			Switch-off time 2 thermostat	23
t3 E		x			x			x			Switch-on time 3 thermostat	23
t3 A		x			x			x			Switch-off time 3 thermostat	23
OHQM	x	x	x	x	x	x	x	x	x	x	Option HQM	19
VIMP	①	①	①	①	①	①	①	①	①	①	Impulse rate volume flow counter	19
MEDT	①	①	①	①	①	①	①	①	①	①	Antifreeze	19
MED %	MEDT	MEDT	MEDT	MEDT	MEDT	MEDT	MEDT	MEDT	MEDT	MEDT	Antifreeze concentration	19
CS 10	x	x	x	x	x	x	x	x	x	x	Solar cell	19
n MN											Minimum pump speed relais 1	23
n1MN	x	x	x	x	x	x	x	x	x	x	Minimum pump speed relais 1	23
n2MN	x	x	x	x	x	x	x	x	x	x	Minimum pump speed relais 2	23
n3MN				x		x				x	Minimum pump speed relais 3	23
MAN1	x	x	x	x	x	x	x	x	x	x	Manual operation relais 1	23
MAN2	x	x	x	x	x	x	x	x	x	x	Manual operation relais 2	23
MAN3	x	x	x	x	x	x	x	x	x	x	Manual operation relais 3	23
MAN4	x	x	x	x	x	x	x	x	x	x	Manual operation relais 4	23
MAN5	x	x	x	x	x	x	x	x	x	x	Manual operation relais 5	23
MAN6	x	x	x	x	x	x	x	x	x	x	Manual operation relais 6	23
LANG	x	x	x	x	x	x	x	x	x	x	Language	23
PROG	XX.XX										Programme version	
VERS	X.XX										Version	

Channel survey: Systems Arr 30...36

Channel	Arr						Description	Page
	31	32	33	34	35	36		
COL	x	x	x	x	x	x	Collector temperature 1	18
COL 1							Collector temperature 1	18
TSTL	x	x	x	x	x	x	Tank temperature lower	18
TST1							Tank temperature 1 lower	18
TSTU	x	x	x	x	x	x	Tank temperature 1 at the top	18
S4							Tank temperature at the middle	18
TST2		x	x	x	x	x	Tank temperature 2 lower	18
TFSB							Temperature solid fuel boiler	18
TRET	x	x	x	x	x	x	Temperature heating circuit	18
COL2							Collector temperature 2	18
TFL	①						Temperature flow sensor	18
TRF	①						Temperature return sensor	18
IRR	x						Solar irradiation intensity	18
n %							Pump speed Relais	18
n1 %	x						Pump speed Relais 1	18
n2 %		x	x	x	x	x	Pump speed Relais 2	18
n3%	x						Pump speed Relais 3	18
hP							Hours of operation relais 1	18
h P1	x	x	x	x	x	x	Hours of operation relais 1	18
h P2		x	x	x	x	x	Hours of operation relais 2	18
h P3	x	x		x	x	x	Hours of operation relais 3	18
FLOW	①	①	①	①	①	①	Volume flow	19
kWh	①	①	①	①	①	①	Heat quantity kWh	19
MWh	①	①	①	①	①	①	Heat quantity MWh	19
TIME	x						Time	19
Arr	1-36						System	9
DT O	x	x					Switch-on temperature difference	20
DT1O			x	x	x	x	Switch-on temperature difference 1	20
DT F	x	x					Switch-off temperature difference 1	20
DT1F			x	x	x	x	Switch-off temperature difference 1	20
DT S	x	x					Set temperature difference	20
DT1S			x	x	x	x	Set temperature difference 1	20
RIS	x	x					Rise	20
RIS1			x	x	x	x	Rise 1	20
S MX	x	x					Maximum tank temperature 1	20
S1 MX			x	x	x	x	Maximum tank temperature 1	20
DT2O			x	x	x	x	Switch-on temperature difference 2	20
DT2F			x	x	x	x	Set temperature difference 2	20
DT2S			x	x	x	x	Set temperature difference 2	20
RIS2			x	x	x	x	Rise 2	20
S2MX			x	x	x	x	Maximum tank temperature 2	20
EM	x						Emergency collector temperatur 1	21
NOT1		x	x	x	x	x	Emergency collector temperatur 1	21

Chan- nel	Arr								Description	Page	
	31	32	33	34	35	36					
OCX	x	x	x							Option Collector cooling collector 1	21
OCX1				x	x	x				Option Collector cooling collector 1	21
CMX	x*	x*	x*							Maximum collector temperature 1	21
CMX1				x*	x*	x*				Maximum collector temperature 1	21
OCN	x	x	x							Option min. limitation collector 1	21
OCN1				x	x	x				Option min. limitation collector 1	21
CMN	x*	x*	x*							Minimum temperature collector 1	21
CMN1				x*	x*	x*				Minimum temperature collector 1	21
OCF	x	x	x							Option antifreeze collector 1	21
OCF1				x	x	x				Option antifreeze collector 1	21
CFR	x*	x*	x*							Antifreeze temperature collector 1	21
CFR1				x*	x*	x*				Antifreeze temperature collector1	21
EM2				x	x	x				Emergency temperature collector 2	21
OCX2				x	x	x				Option collector cooling collector 2	21
CMX2				x*	x*	x*				Maximum temperatur collector 2	21
OCN2				x	x	x				Option min. limitation collector 2	21
CMN2				x*	x*	x*				Minimum temperature collector 2	21
OCF2				x	x	x				Option antifreeze collector 2	21
CFR2				x*	x*	x*				Antifreeze temperature collector 2	21
PRIO	x	x	x		x	x	x			Priority	22
tSP	x	x	x		x	x	x			Stop time	22
tRUN	x	x	x		x	x	x			Circulation	22
OREC	x	x	x	x	x	x	x			Option recooling	22
OTC	x	x	x	x	x	x	x			Option tube collector	22
DT3O	x	x	x	x	x	x				Switch-on temperature difference 3	20
DT3F	x	x	x	x	x	x	x			Switch-off temperature difference 3	20
DT3S	x					x	x			Set temperature DT3	20
RIS3	x					x	x			Rise DT3	20
MX3O	x					x	x			Switch-on step max. temperature	20
MX3F	x					x	x			Switch-off step max. temperature	20
MN3O	x					x	x			Switch-on step min. temperature	20
MN3F	x					x	x			Switch-off step min. temperature	20
AH O			x	x						Switch-on temperature thermostat	23
AH F			x	x						Switch-off temperature thermostat	23
t1 E			x	x						Switch-on time 1 thermostat	23
t1 A			x	x						Switch-off time 1 thermostat	23
t2 E			x	x						Switch-on time 2 thermostat	23
t2 A			x	x						Switch-off time 2 thermostat	23
t3 E			x	x						Switch-on time 3 thermostat	23
t3 A			x	x						Switch-off time 3 thermostat	23
OHQM	x	x	x	x	x	x	x			Option HQM	19
VIMP	①	①	①	①	①	①	①			Impulse rate volume flow counter	19
MEDT	①	①	①	①	①	①	①			Antifreeze	19
MED %	MEDT	MEDT	MEDT	MEDT	MEDT	MEDT	MEDT			Antifreeze concentration	19
CS 10	x	x	x	x	x	x	x			Solar cell	19
n MN		x								Minimum pump speed relais 1	23
n1MN	x		x	x	x	x	x			Minimum pump speed relais 1	23
n2MN				x	x	x	x			Minimum pump speed relais 2	23
n3MN	x					x	x			Minimum pump speed relais 3	23
MAN1	x	x	x	x	x	x	x			Manual operation relais 1	23
MAN2	x	x	x	x	x	x	x			Manual operation relais 2	23
MAN3	x	x	x	x	x	x	x			Manual operation relais 3	23
MAN4	x	x	x	x	x	x	x			Manual operation relais 4	23
MAN5	x	x	x	x	x	x	x			Manual operation relais 5	23
MAN6	x	x	x	x	x	x	x			Manual operation relais 6	23
LANG	x	x	x	x	x	x	x			Language	23
PROG	XX.XX									Programme version	
VERS	X.XX									Version	

4.2 Indication channels

Please note:

The indication channels are system dependant. Only the values necessary for the adjusted systems Arr 1...36 (see channel overview pages 10 ff) are shown.

4.2.1 Indication of collector temperatures

COL, COL1, COL2:

collector temperature
Display range: -40...+250 °C



Shows current collector temperature.

COL: Collector temperature (1-collector-system)

COL1: Collector temperature 1

COL2: Collector temperature 2

4.2.2 Indication of tank temperatures

TSTL,TSTU, TST1,TST2,S4:

Tank temperatures
Display range: -40...+250 °C

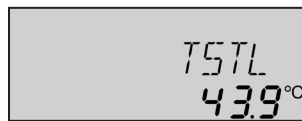

Shows current tank temperature.

TSTL: Tank temperature below

TSTU: Tank temperature above

TST1: Temperature tank 1

TST2: Temperature tank 2

S4: Temperature tank middle

4.2.3 Anzeige sonstiger Temperaturen

TFSB,TRET,TRF,TFL:

other measuring
temperatures
Display channel:
-40...+250 °C



Shows current temperature of the corresponding sensor.

TFSB: Temperature solid hot fuel boiler

TRET: Temperature heating circuit reverse raising

TRF: Temperature return flow

TFL: Temperature feed flow

4.2.4 Indication of solar irradiation intensity

IRR current irradiation

Display channel:
0...1350W/m²

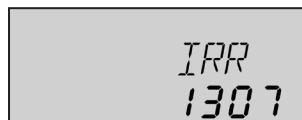

Shows current solar irradiation intensity.

IRR: solar irradiation intensity

4.2.5 Indication of current pump speed

n %, n1 %, n2 %, n3%:

current pump speed
Display channel: 30...100 %

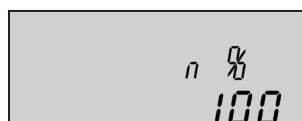

Shows current pump speed of the corresponding pump.

n %: current pump speed (1-pump-system)

n1 %: current pump speed of pump 1

n2 %: current pump speed of pump 2

n3 %: current pump speed of pump 3

4.2.6 Operating hours counter

h P / h P1 / h P2 / h P3:

Operating hours counter
Display channel

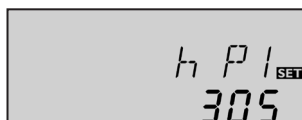

The operating hours counter adds up the solar operating hours of the respective relay (**h P / h P1 / h P2**). Full hours are shown on the display. The operating hours added up can be reset. As soon as one operating hours channel is selected, the symbol in

permanently shown on the display. The button SET (3) must be pressed for approx. 2 seconds in order to get back into the RESET-mode of the counter. The display-symbol is flashing and the operating hours will be set to 0. In order to finish the RESET-procedure, the button must be pressed in order to confirm. In order to interrupt the RESET-procedure, no button should be pressed for about 5 seconds. The controller returns automatically into the indication mode.

4.2.7 Volume flow

FLOW: Volume flow
Adjustment range
0,00 ... 99,99 m³/h



The volume flow of the solar system measured by the V40 to determine the transported heat amount.

4.3 Adjustment channels

Please note:

The adjustment channels are system dependent as well as the indication channels. Only that values necessary for the adjusted systems Arr 1 ... 36 (see channel overview from page 10 ff) can be modified.

4.3.1 Heat quantity balancing

OHQM: Heat quantity balancing
Adjustment range OFF ... ON
Factory setting OFF



In general a heat quantity balancing is possible in conjunction with a RESOL V40 in all selectable channels. You only have to activate the option heat quantity measurement in the channel **OHQM**.

MEDT: Type of antifreeze
Adjustment range 0 ... 3
Factory setting 1



The volume flow measured at V40 (see indication channel VSTR) enables in conjunction with type and content of antifreeze of the heating medium the heat balancing.

MED%: Content of antifreeze in (Vol-) %
MED% is blinded out at MEDT 0 and 3
Adjustment range 20 ... 70
Factory setting 45



Antifreeze:

- 0: water
- 1: propylene glycol
- 2: ethylene glycol
- 3: Tyfocor® LS / G-LS

kWh/MWh: Heat quantity in kWh / MWh
Indication channel



The heat quantity transported is measured by the indication of the volume flow and the reference sensor of feed flow S7 and return flow sensor S8. It is shown in kWh-parts in the indication channel **kWh** and in MWh-parts in the indication channel **MWh**. The sum of both channels form the total heat output.

FIMP: Volume per impuls
Adjustment range 1 ... 99
Factory setting 1

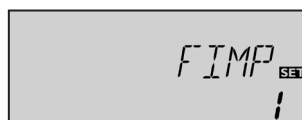

The heat quantity added up can be reset. As soon as one of the display channels of the heat quantity is selected, the symbol **SET** is permanently shown on the display. The button SET (3) must be pressed for approx. 2 seconds in order to get back into the RESET-mode of the counter. The display-symbol **SET** is flashing and the value for heat quantity will be set to 0. In order to finish the RESET procedure, the button must be pressed in order to confirm. In order to interrupt the RESET-procedure, no button should be pressed for about 5 seconds. The controller returns automatically into the indication mode.

Please note:

You can find the l/imp of your flowmeter printed on a flag that is attached to its cable.

IRR: Solar irradiation intensity in W/m²
Indication channel

CS10: Solar cell
Adjustment range 1 ... 10
Factory setting 5

Type	Indicator
A	1
B	2
C	3
D	4
E	5
F	6
G	7
H	8
I	9
K	10

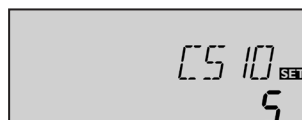

The current solar irradiation intensity is measured in W/m² by the sensor RESOL CS10.

The sensor is divided into different types (see imprint on packaging) and must be adjusted in channel CS10 with the corresponding code number (see commissioning). The current irradiation is now shown in channel **SOL**.

4.3.2 ΔT -regulation

DT O / DT1O / DT2O / DT3O:

Switch-on temp.diff. adjustment
range 1,0 ... 20,0K
Factory setting 6.0



DT F / DT1F / DT2F / DT3F:

Switch-off temp.- diff. adjust-
mentrange 0,5 ... 19,5K
Factory setting 4.0 K

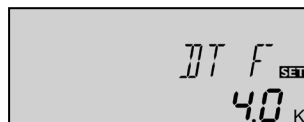

Note: The switch-on temperature difference must be at least 1 K higher than the switch-off temperature difference.

DT S / DT1S / DT2S / DT3S:

Nominal temp. diff.
adjustment range 1,5 ... 30,0K
Factory setting 10.0

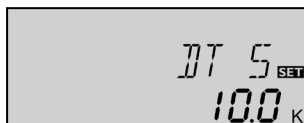

RIS / RIS1 / RIS2 / RIS3:

Rise
Adjustment range 1 ... 20K
Factory setting 2 K

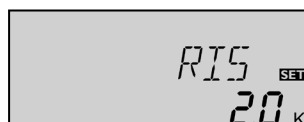

4.3.3 Maximum tank temperature

S MX / S1MX / S2MX:

Maximum tank temp.
adjustment range 2 ... 95 °C
Factory setting 60 °C

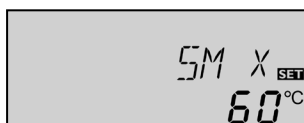

Primarily the controller works in the same way like a standard differential controller. If the switch-on difference (**DT O / DT1O / DT2O / DT3O**) is reached, the pump is activated and after having got an impulse (10 s) a minimum pump speed (nMN=30 %) will be run. If the adjusted nominal value of the temperature difference is reached (**DT S / DT1S / DT2S / DT3S**), the pumps speed will be increased by one step (10 %). If the difference increases by 2 K (**RIS / RIS1 / RIS2 / RIS3**), the pump speed will be increased by 10 % respectively until the maximum pump speed of 100 % is reached. The response of the controller can be adapted by means of the parameter „Anstieg“ (rise). If the adjusted switch-off temperature is underrun (**DT F / DT1F / DT2F / DT3F**), the controller switches-OFF.

If the adjusted maximum tank temperature is exceeded, a further loading of the tank will be stopped so that a damaging overheating can be avoided. If the maximum tank temperature is exceeded, in the display is shown ☀.

Please note: The controller is equipped with a security switch-off of the tank, which avoids a further loading of the tank if 95 °C is reached at the tank.

4.3.4 ΔT -regulation (solid fuel boiler and heat exchange)

Maximum temperature limitation

MX3O / MX3F:

Maximum temperature
limitation
Adjustment range
0,0 ... 95,0 °C

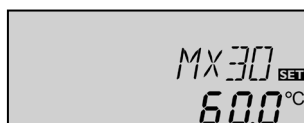

Factory setting:
MX3O 60,0 °C
MX3F 58,0 °C

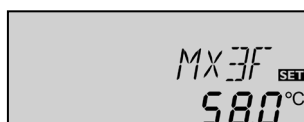

Minimum temperature limitation

MN3O / MN3F:

Minimum temperature limi-
tation
Adjustment range
0,0 ... 90,0 °C



Factory setting:
Arr = 2
MN3O 5,0 °C
MN3F 10,0 °C
Arr = 8
MN3O 60,0 °C
MN3F 65,0 °C



The controller is equipped with an independent temperature differential regulation for which minimum and maximum temperature limitations as well as corresponding switch-on and -off temperatures can be separately adjusted. Only possible for Arr = 2, 8, 11, 13, 16, 17, 18, 20, 24, 26 and 30 (e.g. for solid hot fuel boilers or heat exchange regulation.)

If the adjusted value **MX3O** is exceeded, the relais 3 would be deactivated. By falling under the parameter **MX3F** the relais switches on again.

Reference sensor:

S3 at Arr 8, 13, 20, 26 (TSTU)

S4 at Arr 2, 11, 16, 17, 18, 24, 30 (TST2, TFSB)

If the the temperature is fallen below the adjusted value **MN3O**, the relais 3 would be deactivated. By exceeding the parameter **MN3F** the relais switches on again.

Reference sensor:

S4 at Arr 8, 13, 20, 26 (TST2, TFSB)

S3 at Arr 2, 11, 16, 17, 18, 24, 30 (TSTU)

Both apply for the maximum temperature limitation and the minimum temperature limitation as well as the switch-on and -off temperature differences **DT3O** and **DT3F**.

4.3.5 Collector-limit temperature collector emergency shutdown

EM / EM1 / EM2:

collector limitation temperature
adjustment range:
110 ... 200 °C,
factory setting 140 °C

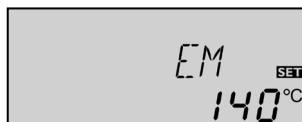

If the adjusted collector limit temperature (**EM / EM1 / EM2**) is exceeded the solar pump (R1 / R2) is deactivated in order to avoid a damaging overheating of the solar components (collector emergency shutdown). The limit temperature is set to 140 °C by RESOL but it can be changed within the adjustment range of 110 ... 200 °C. In the display is shown  (flashing).

4.3.6 System cooling

OCX / OCX1 / OCX2:

Option system cooling
adjustment range:
OFF ... ON

Factory setting OFF

CMX / CMX1 / CMX2:

Collector maximum temperature
adjustment range:
100... 190 °C
factory setting 120 °C

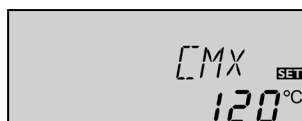
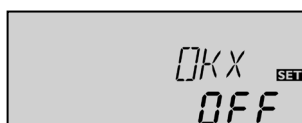

If the adjusted maximum tank temperature is reached, the solar system switches-off. If now the collector temperature raises to the adjusted maximum collector temperature (**CMX / CMX1 / CMX2**) the solar pump remains activated until this limit temperature value is again underrun. The tank temperature might continue to raise (subordinated active maximum tank temperature), but only until 95 °C (emergency shutdown of the tank). If the tank temperature is higher than the maximum tank temperature (**S MX / S1MX / S2MX**) and the collector temperature is by at least 5K lower than the tank temperature, the solar system remains activated until the tank is again cooled down (- 2K) by the collector and the tubes under the adjusted maximum temperature (**S MX / S1MX / S2MX**). In case of active system cooling on the display is shown  (flashing) angezeigt. Due to the cooling function the solar system can be kept operable for a longer period on hot summer days and a thermal release of the collector and the heat transfer medium is ensured as well.

4.3.7 Option minimum collector limitation

OCN / OCN1 / OCN2:

Minimum collector limitation
Adjustment range OFF / ON
Factory setting OFF



CMN / CMN1 / CMN2:

Minimum collector temperature
adjustment range 10 ... 90 °C
factory setting 10 °C

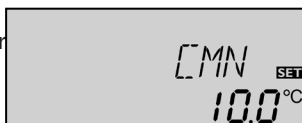

The minimum collector temperature is a minimum switching temperature, which must be exceeded so that the solar pump (R1/R2) is switched-on. The minimum temperature shall avoid a steady starting-up of the solar pump (or solid fuel boiler charging pumps) for low collector temperatures. If the minimum temperature is underrun, in the display is shown  (flashing).

4.3.8 Option antifreeze function

OCF / OCF1 / OCF2:

Antifreeze function
adjustment range OFF / ON
factory setting OFF



CFR / CFR1 / CFR2:

Antifreeze temperature
adjustment range:
-10 ... 10 °C
factory setting 4,0 °C



The antifreeze function activates the loading circuit between collector and tank if the adjusted antifreeze function is underrun in order to protect the medium that it will not freeze or „get thick“. If the adjusted frost protection temperature is exceeded by 1 °C, the loading circuit will be deactivated.

Please note: As there is only a limited heat quantity of the tank available for this function, the anti freeze function should only be used in regions with few days of temperatures around freezing point.

4.3.9 Oscillating charge

Respective adjustment values:

Priority [PRIO]

oscillating break-time [tSP]

oscillating charge time [tRUN]

Factory setting

1 (2 / Layer tank)

2 min.

15 min.

Adjustment range

0-2

1-30 min.

1-30 min.

DeltaSol® ES priority logic:

Priority:



The above-mentioned options and parameters are only relevant for multi-tank systems.

PRIO 0: in 2-tank systems with pump logic (e.g. Arr 6 and 17) if possible, parallel loading is effected;

in 2-tank systems with valve logic (e.g. Arr 5) loading is effected in numerical order.

PRIO 1: priority loading of tank 1

PRIO 2: priority loading of tank 2

Oscillating break time / oscillating charge time / collector rising temperature:

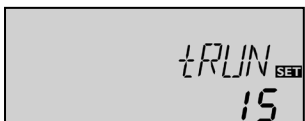
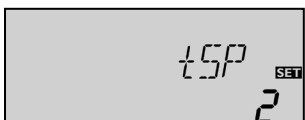

The controller checks the tanks regarding loading facilities (switch-on difference). If the priority tank cannot be loaded, the lower-ranking tank is checked. If the lower-ranking tank can be charged, this is effected by the so-called „oscillating charge time“ (**tRUN**) After termination of the oscillating charge time, loading is stopped. The controller controls the increase in collector temperature. If it increases by the collector rising temperature (ΔT_{Kol} 2 K, fixed software value), the expired break time is again reset to zero and the oscillating break time starts again. If the switch-on conditions of the priority tank is not reached, the loading of the lower-ranking tank is continued. If the priority switch has reached its maximum temperature, the oscillating charge is not effected.

4.3.10 Recooling function

OREC:

Option recooling

adjustment range

OFF ...ON

factory setting OFF



If the adjusted maximum tank temperature (S_{MAX}, S_{1MX}, S_{2MX}) is reached, the solar pump remains activated in order to avoid an overheating of the collector. The tank temperature might continue to increase but only up to 95 °C (emergency shutdown of the tank). In the evening the solar system continues running until the tank is cooled down to the adjusted maximum tank temperature via collector and pipes.

4.3.11 Tube collector special function

OTC:

tube collector special
function

adjustment range

OFF ...ON

factory setting OFF

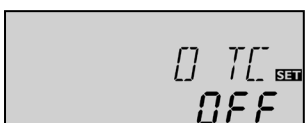

If the controller measures an increase of 2 K compared to the collector temperature stored at last, the solar pump is switched-on to 100 % for about 30 seconds. After expiration of the solar pump runtime the current collector temperature is stored as new reference value. If the measured temperature (new reference value) is again exceeded by 2 K, the solar pump again switches-on for 30 seconds. If the switch-on difference between collector and store is again exceeded during runtime of the solar pump or the standstill of the system, the controller automatically switches over to solar charging. If the collector temperature drops by 2 K during standstill, the switch-on value for the special tube collector function will be recalculated.

4.3.12 Thermostat function

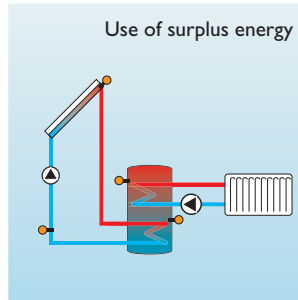
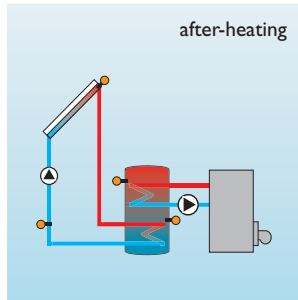

AH O:
Thermostat-switch-on temperature
adjustment range:
0,0...95,0 °C
factory setting: 40,0 °C



AH F:
Thermostat-switch-off temperature
adjustment range:
0,0...95,0 °C
factory setting: 45,0 °C



t1 O, t2 O, t3 O:
Thermostat switch-on time
adjustment range:
00:00...23:45
factory setting: 00:00

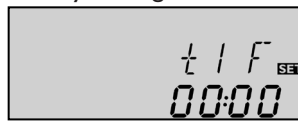

t1 F, t2 F, t3 F:
Thermostat switch-off time
adjustment range:
00:00...23:45
factory setting: 00:00

The thermostat function works independently from the solar operation and can e.g. be used for use of surplus energy or an after-heating.

- **AH O < AH F**
thermostat function is used for after-heating
- **AH F > AH O**
thermostat function is used for use of surplus energy

3 time slots t1...t3 are available for temporary blocking of thermostat function. If the thermostat function e. g. is only used between 6:00 and 9:00 a.m., the following adjustments have to be made: **t1 O** 6:00 and **t1 F** 9:00. Factory setting: thermostat function is permanently activated. If all time slots stop at 00:00 Uhr, the thermostat function is permanently activated (factory setting).

4.3.13 Pump speed control

nMN, n1MN, n2MN, n3MN:

Minimum pump speed control
adjustment range: 30...100
factory setting: 30



A relative minimum pump speed is specified for pumps connected at the outputs R1 and R2 via adjustment channels **nMN, n1MN** and **n2MN**.

Attention:

When using consumers (e.g. valves) which are not pump speed controlled, the value must be adjusted to 100 % in order to deactivate the pump speed control.

4.3.14 Operating mode

MAN1, MAN2, MAN3, MAN4, MAN5, MAN6:

Operating mode
adjustment range:
OFF,AUTO,ON
factory setting: AUTO

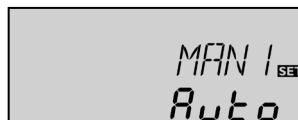

Channel	Relais
HNDx	1-6

For control- and service work the operating mode of the controller can be manually adjusted by selecting the adjustment value MAN1-6, in which the following adjustments can be made:

- **MAN1, MAN2, MAN3, MAN4, MAN5, MAN6**

Operating mode

OFF : relay off ⚠ (flashing) + 🖐

AUTO : relay in automatic operation

ON : relay on ⚠ (flashing) + 🖐

4.3.15 Language (LANG)

LANG:

Adjustment of language
adjustment range: dE,En,It,Fr
factory setting: dE

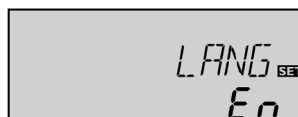

The menu language can be adjusted in this channel.

- dE : German
- En : English
- It : Italiano
- Fr : French

5. Tips for fault localization

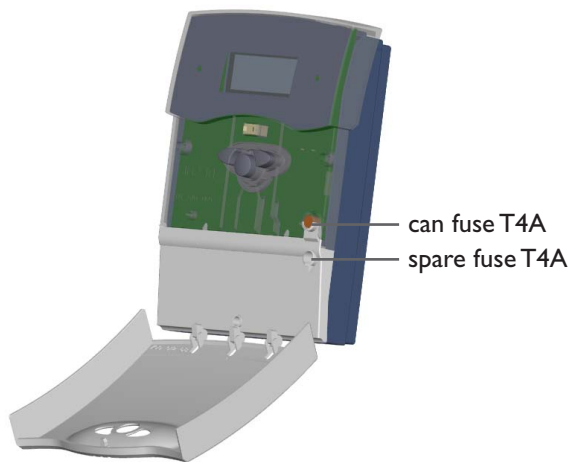

If a malfunction occurs, a notification is given on the display of the controller :

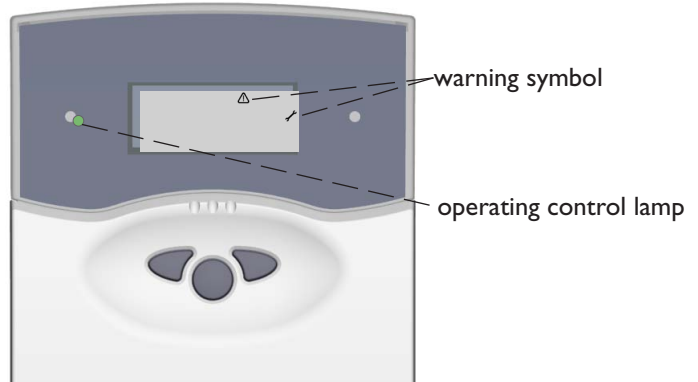

Operating control lamp flashes red. On the display appears the symbol and the symbol flashes.

Sensordefect. An error code is shown on the relevant sensor indicator channel instead of a temperature.

888.8

- 88.8

Line break. Check the line.

Short-circuit. Check the line.

Pt1000-temperature sensors pinched off can be checked with an ohmmeter. In the following the resistance values corresponding to different temperatures are listed.

°C	Ω	°C	Ω
-10	961	55	1213
-5	980	60	1232
0	1000	65	1252
5	1019	70	1271
10	1039	75	1290
15	1058	80	1309
20	1078	85	1328
25	1097	90	1347
30	1117	95	1366
35	1136	100	1385
40	1155	105	1404
45	1175	110	1423
50	1194	115	1442

Resistances of Pt1000-sensors

Operating control lamp permanently expires.

The power supply of the controller is to be checked if the control lamp goes out.

no

o.k.

The can fuse of the controller is defective. It can be replaced after having dropped off the cover (spare fuse is enclosed in the accessory bag).

5.1 Miscellaneous:

Pump is overheated, but no heat transfer from collector to the tank, feed flow and return flow are the same warm; perhaps also bubble in the lines.

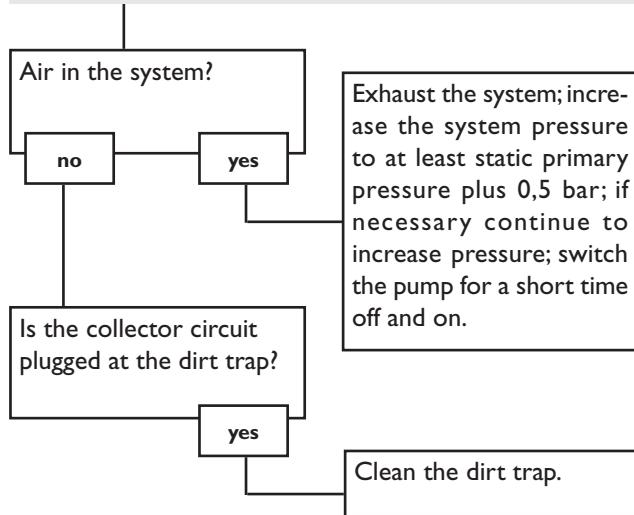

Pump starts for a short moment, switches-off, switches-on again, etc. („controller jitting“)

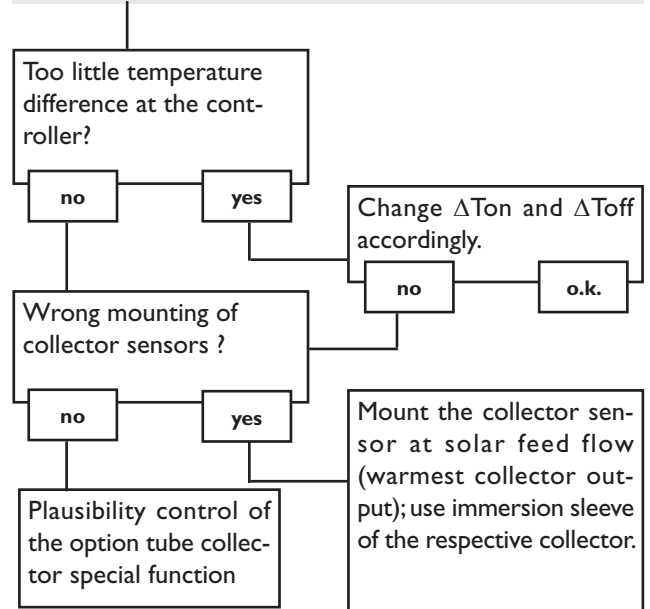

Pump starts up very late and stops working soon.

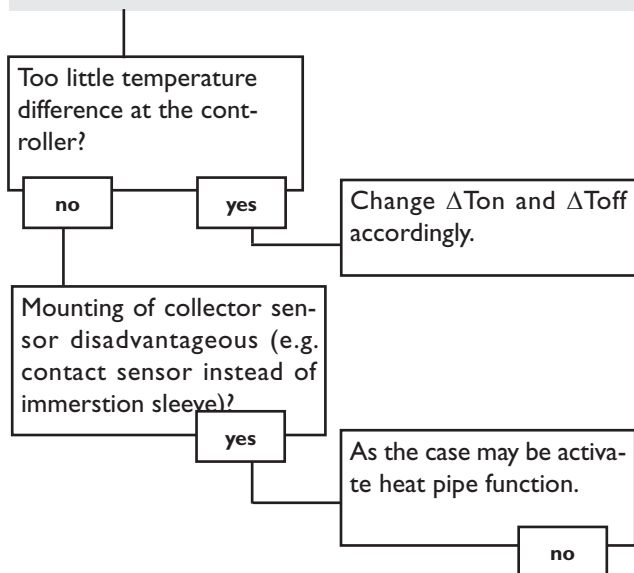

The temperature difference between tank and collector increases enormously during operation; the collector circuit cannot dissipate the heat.

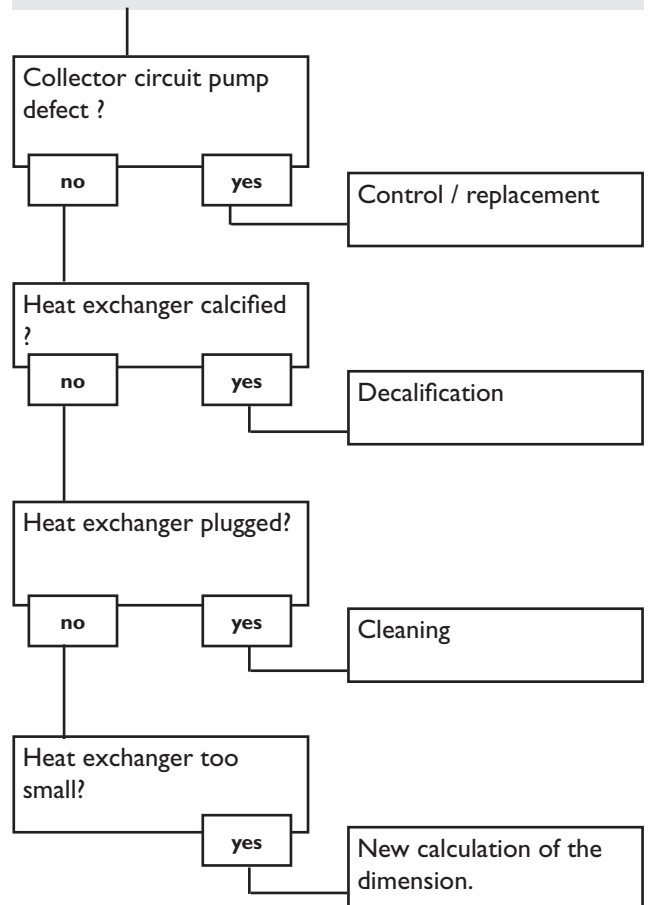

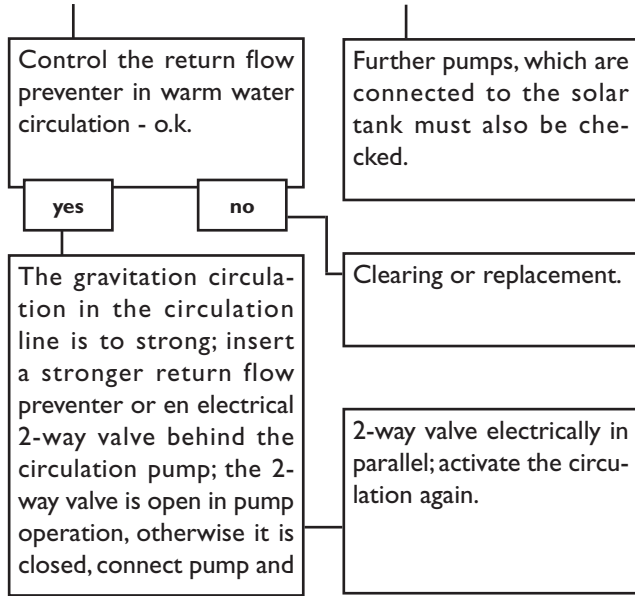
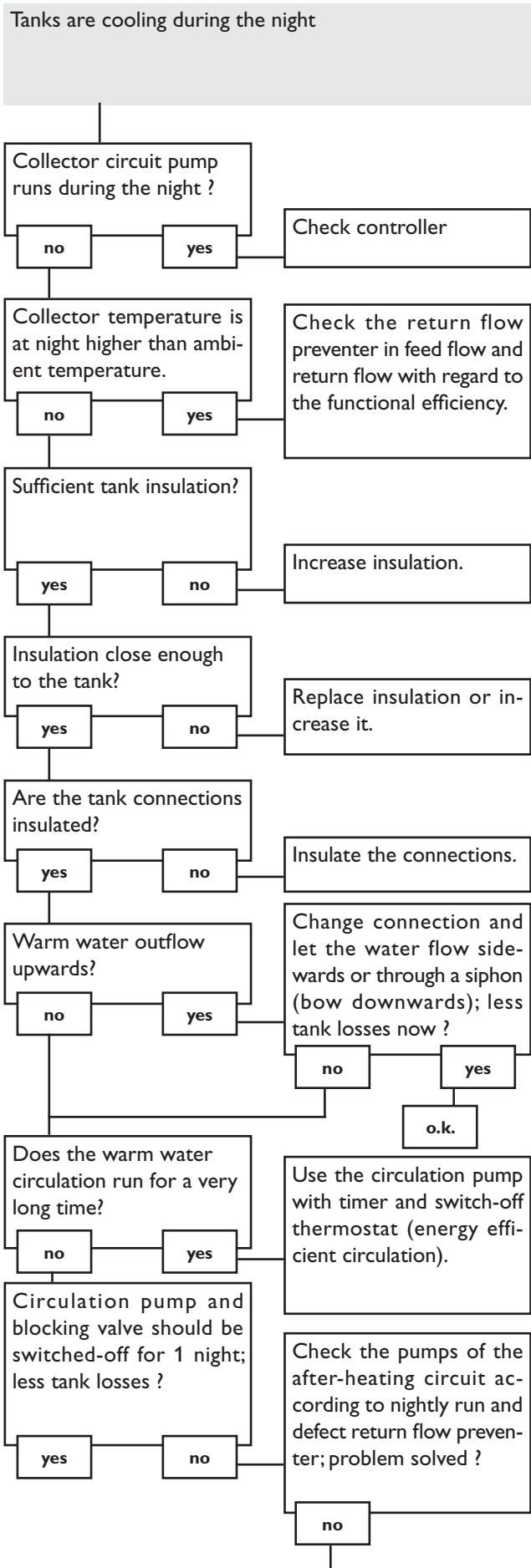

The solar circuit pump does not work, although the collector is obviously warmer than the tank.

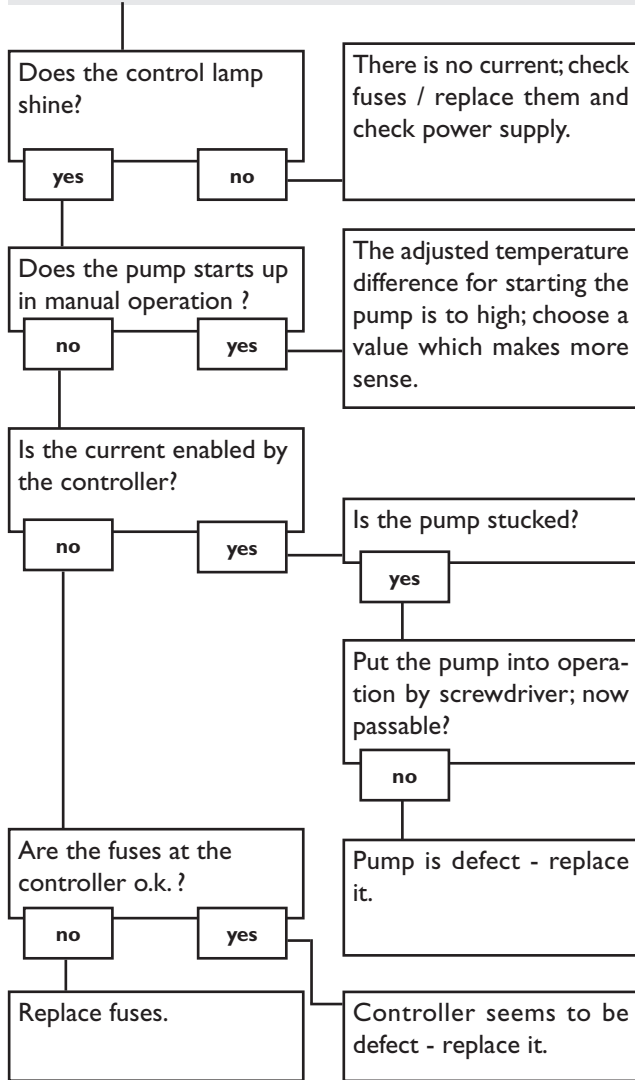

6. Accessory

Sensors

Our product range includes high-precision platinum temperature sensors, flatscrew sensors, ambient temperature sensors, indoor temperature sensors, cylindrical clip-on sensors and irradiation sensors, also to be used as full sensors with sensor pocket.



Overvoltage protection

We highly recommend to install the overvoltage protection in order to avoid overvoltage damages at the collector (e.g. by lightning).



RESOL V40

If you are interested in realising a heat quantity balancing, a RESOL V40 is needed for measurement of the volume flow in the system.



RESOL Service Center Software

The RSC light software enables a readout of the measured values of the controller for visualisation and control of the system. For free download of the software, please click on www.resol.de.

RESOL - Elektronische Regelungen GmbH

Heiskampstraße 10
D - 45527 Hattingen

Tel.: +49 (0) 23 24 / 96 48 - 0
Fax: +49 (0) 23 24 / 96 48 - 55

www.resol.de
info@resol.de

Your specialist dealer:

Please note:

The design and the specifications are to be changed without notice.
The illustrations may differ from original product.