

# RESOL HKM2

## Heating circuit module

Operation

Mounting

Electrical Connection



48003370

Thanks for buying.  
Read this manual carefully to get the best performance from this unit.

# HKM2



manual

[www.resol.de](http://www.resol.de)

## Contents

<b>Security instruction</b> .....	<b>2</b>	<b>4. Operation and Adjustment</b> .....	<b>10</b>
<b>Application examples</b> .....	<b>4</b>	4.1 Control parameters.....	10
<b>1. Installation</b> .....	<b>5</b>	4.1.1 Feed flow set temperature .....	11
1.1 Wall mounting.....	5	4.1.2 Ambient temperature .....	11
1.2 Electrical connection .....	5	4.1.3 Remote control correction.....	11
1.3. Connecting terminals.....	6	4.1.4 Feed flow set temperature .....	11
<b>2. Sensor types</b> .....	<b>7</b>	4.1.5 Store temperature .....	11
<b>3. Function survey</b> .....	<b>8</b>	4.1.6 Nightly temperature lowering.....	11
3.1 Heating circuit.....	8	4.1.7 Daily correction.....	11
3.2 Timer .....	8	4.1.8 Maximum feed flow temperature.....	12
3.3 Remote control .....	8	4.1.9 Heating curve.....	12
3.4 Switch-off heating circuit.....	8	4.1.10 Mixer runtime.....	12
3.5 Rapid heating-up.....	8	4.1.11 Summer operation .....	12
3.6 Feed flow set temperature .....	9	4.1.12 Domestic water priority .....	12
3.7 Mixer regulation .....	9	4.1.13 Timer .....	12
3.8 Domestic water priority .....	9	4.1.14 HKM expert.....	13
3.9 Blocking protection of the heating circuit pump .....	9	4.1.15 Manual operation .....	14
3.10 Anti-freeze function.....	9	4.1.16 LED-Blinking codes.....	14
3.11 Store after-heating .....	9	<b>5. Commissioning</b> .....	<b>14</b>
		<b>6. Tips for fault localization</b> .....	<b>14</b>
		6.1 Cause and solution .....	15

### Security advice

Please pay attention to the following security advice in order to avoid danger and damage to people and property.

### Instructions

Attention should be paid

- to the statutory provisions for prevention of industrial accidents,
- to the statutory provisions for environmental protection,
- to the Health and Safety at Work Act 1974
- to Part P of the Building Regulations 2005
- to BS7671 Requirements for electrical installations and relevant safety regulations of DIN, EN, DVGW, TRGI, TRF and VDE.

This instruction is exclusively addressed to authorised skilled personnel.

- Only qualified electricians should carry out electrical works.
- Initial installation should be effected by named qualified personnel

### Declaration of conformity

We, RESOL Elektronische Regelungen GmbH, D-45527 Hattingen, declare under our sole responsibility that our product HKM2 complies with the following standards:

EN 55 014-1  
EN 60 730-1

According to the regulations of the above directives, the product is labelled with **CE**:

89/336/EWG  
73/ 23/EWG

Hattingen, 07.07.2006  
RESOL Elektronische Regelungen GmbH,



ppa. Gerald Neuse

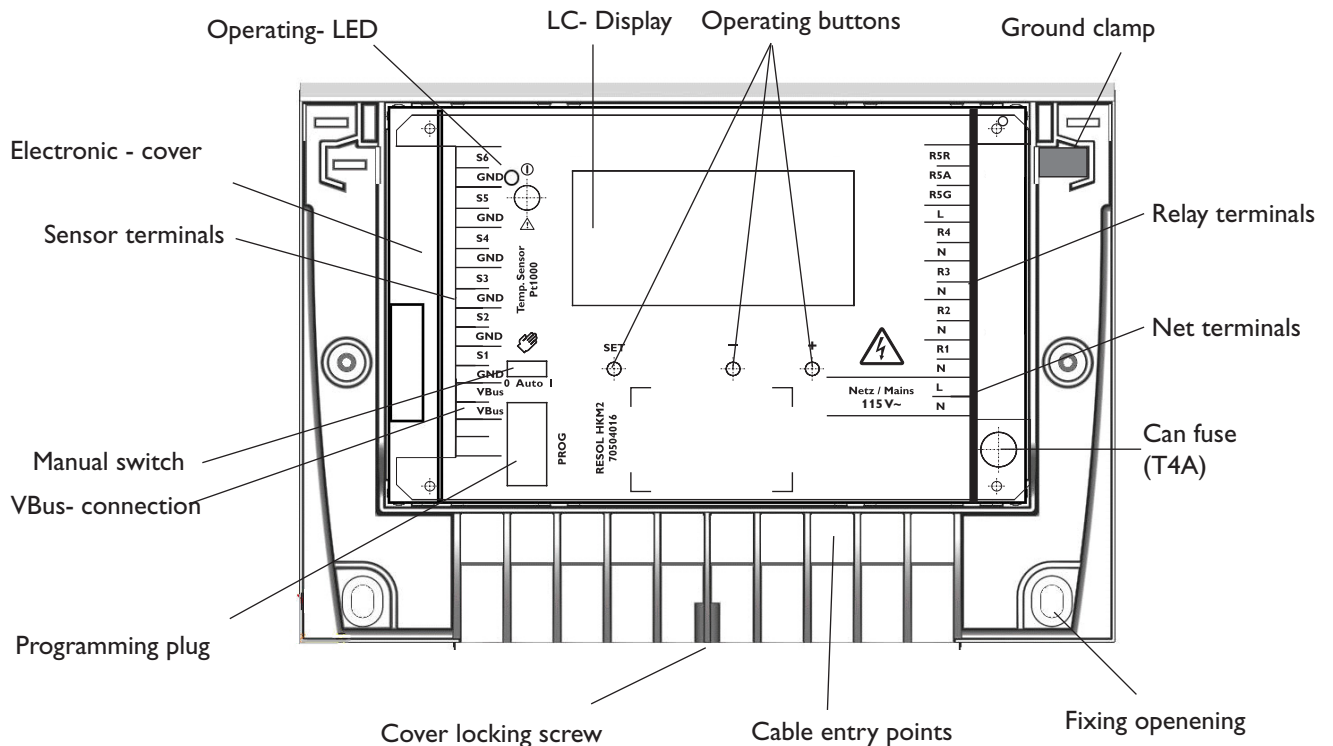

**Information concerning orders:**



- |  | <b>Item number</b> |
|--|--------------------|
| • <b>RESOL HKM2</b><br>Heating circuit module for a heating circuit controlled by atmospheric conditions   | 145 440 30         |
| • <b>RESOL HKM2 - complete package</b><br>Heating circuit module for a heating circuit controlled by atmospheric conditions<br>incl. Ambient temperature sensor FAP12 and Feed flow sensor FRP21 | 145 440 40         |

**Accessory**

**Remote controller RTA11-M**



The remote controller RTA11-M serves for the adjustment of the heating curve of the controller. An increase of the heating curve causes also an increase of the feed flow set temperature, a lowering stands for a decrease of the feed flow set temperature. Furthermore, the remote controller comprises the function „Heating circuit off“ und „Rapid heating up“.

**Information concerning orders**

- |                           |                         |
|---------------------------|-------------------------|
| RTA11-M remote controller | Artikel-Nr.: 136 000 20 |
|---------------------------|-------------------------|

- Heating circuit (weather-controlled)
- Timer (weekly timer)
- Remote control
- Mixer regulation
- Domestic water priority
- Blocking protection of the heating circuit pump
- Anti-freeze function
- Weather-controlled store after-heating

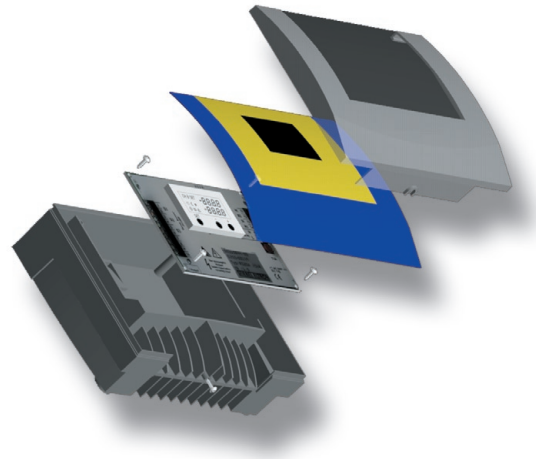

## Technical data

### Housing:

plastic, plug-in

### Protection type

IP20 / DIN40050

### Size:

208 x 141 x 65 mm

### Ambient temperature:

0...40 °C

### Inputs:

4 sensor inputs Pt1000

1 RTA11-M

### Outputs:

4 standard relays

1 potential free change-over contact

**Display:** LC-Display,  
7-segmental-Display

**Adjustment range:**  
-40 °C...+250 °C

**Supply:**  
115 V (AC), 50 ... 60 Hz

**Total power supply:**  
4 A max.

**Bus-Connection**  
RESOL VBus

### Scope of delivery

1 x HKM2

1 x replacement fuse T4A

3 x Screws for Wall fittings

3 x Dowels for Wall fittings

RESOL systems can be extended into heating-/solar controller units by means of the HKM2.

The heating circuit module disposes of :

6 sensor inputs (Pt1000)

5 relay outputs

Operating control lamp

Manual control switch

## Application examples

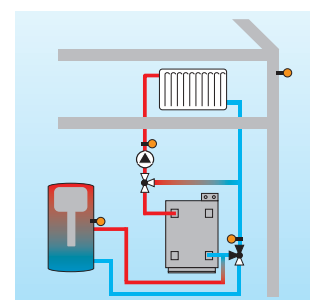
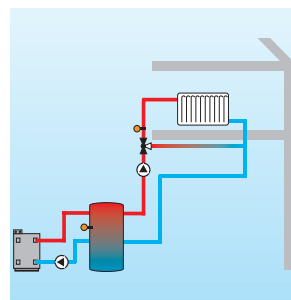
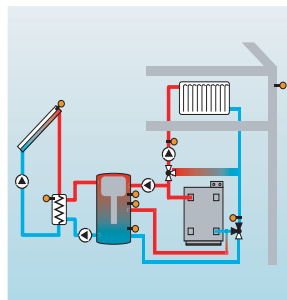
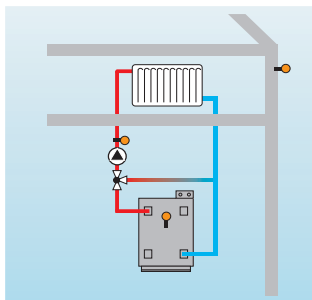

The pictograms included in this manual show only some of the controller functions and do not qualify for being complete. They just illustrate a selection of the possible applications.

## 1. Installation

### 1.1 Wall mounting

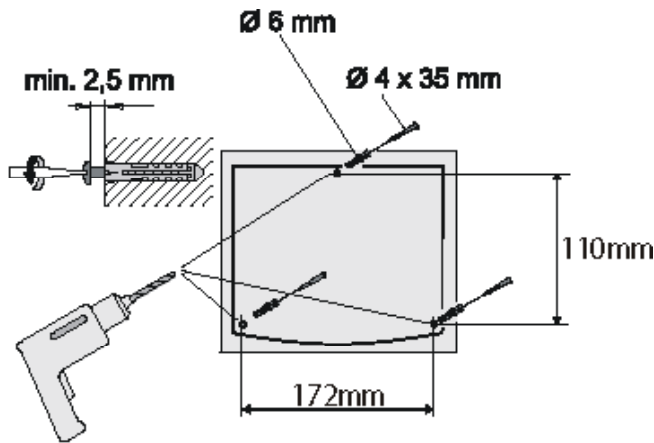

The HKM2 has to be mounted on walls. Please pay attention to the fact that the back of the wall housing is not accessible when controller is mounted. The module in use has to be protected from humidity, dirt and damage. The admissible ambient temperature is from 0 up to 40 °C.

For opening the cover the fastening screw must be unscrewed by just one rotation. In this way the cover can be flapped away.

Please fix the upper screw and hook the housing to the upper hanging. The module can be straightened now, both lower holes must be marked on the wall. After having removed the housing, the lower dowel holes can be drilled. For the upper fixing of the housing, turn the appropriate dowel just as far into the round head screw  $\text{Ø}4 \times 35 \text{ mm}$  so that the housing can be just hooked-on. Now the housing can be screwed by two more screws  $\text{Ø}4 \times 35 \text{ mm}$  at the lower part of the housing.

### 1.2 Electrical Connection



**Warning!**  
Switch-off power supply before opening the housing.

The electrical connection must be effected according to the relative electric connection plan.

The HKM2 must be separated from the power line via an additional device with an all pole break line of at least 3 mm or via a separator according to the valid installation regulations. You can either use LS-contactors or fuses.

#### Electrical lines

The cable ducts at the wall housing are appropriate to fixed and flexible lines with an external diameter of 5 mm up to 12 mm.

The lines are inserted from the bottom into the lead slots and bent into the lead channels. The sheat insulation must be removed approx. 5 cm from the clamps. All lines must be fixed directly below the wall housing with strain reliefs on the wall as prescribed.

Please pay attention to a separate laying of the sensor lines when installing the mains feeder.

### 1.3 Connecting terminals

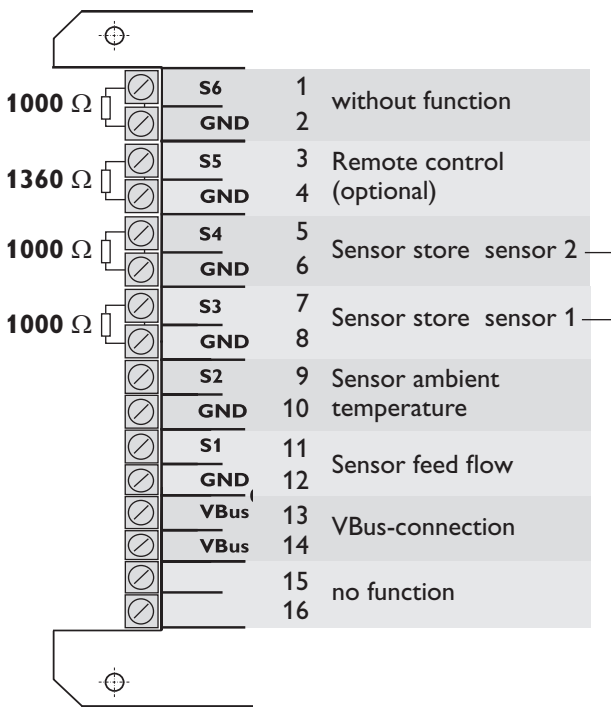

ill.1

**Note:**

The clamps (1-8) are factory-installed with 1000 ohms or 1360 ohms resistors. In case of an appropriate allocation of the clamps, please remove the resistors.

In case that after-heating = Boiler (from DeltaSol® M 1.10 on 2 store sensors can be used)

In case of an after-heating = Thermal- or after-heating = boiler

The connection of the remote control can be effected by terminals 3 and 4. The connection of the sensors can be effected at the terminals 5 to 12 with a user-defined polarity (see terminal scheme illustration 1).

The main controller and the HKM2 module are connected via the RESOL VBus. The connection is effected by a user defined polarity at terminals 13 and 14. The configuration of the module is effected at the main controller. Activate **HK-Module** with the menu of the main controller. From DeltaSol® M version 1.10 on, you can choose between „No“, „HKM1“ und „HKM2“, in the previous versions between „Yes“ and „No“. All adjustments and display values are listed in the corresponding menu (HK-module).

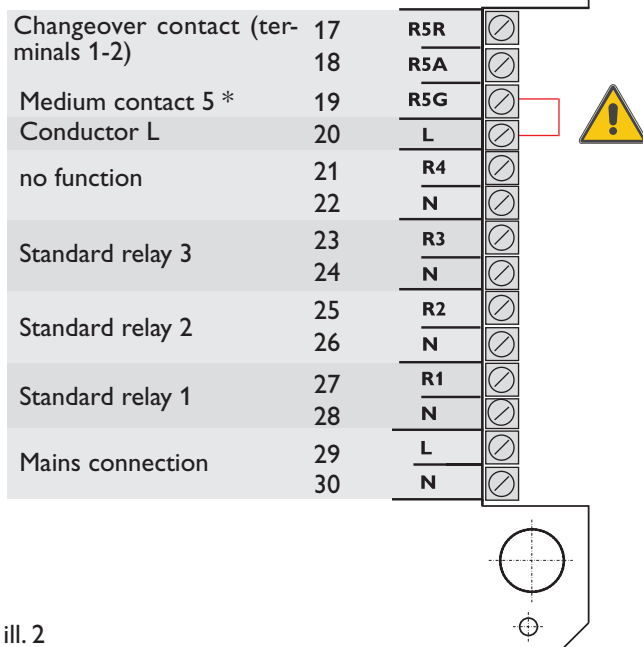

The connection of the consumers must be effected at the terminals 1 to 12 in consideration of the polarity (Rx/N) (see terminal scheme, ill 2). The ground wires are merged in the ground wire collective terminal (illustration3).

\* In the delivery condition terminals 3 and four are connected via a jumper. The removal of the jumper results in a potential-free relay for 115 V consumers at the terminals 1, 2 and 3 (break, work, common center).

The mains connection is to be effected at the terminals:

- 14 = neutral conductor N
- 13 = conductor L
- ground wire - terminal block

- R1 = HL-pump
- R2 = Mixer ON
- R3 = Mixer OFF
- R4 = without function
- R5 = After-heating

Take the ground wire-terminal block from the accessory bag. Connect all ground wires in currentless state and insert it into the deepinings of the terminal block (see position ill. 3).

ill. 2

ill. 3

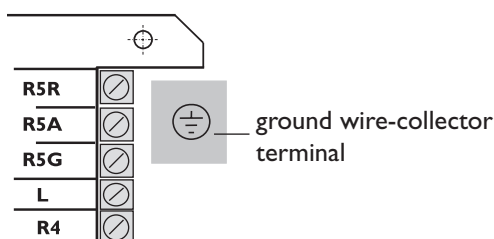

## 2. Sensor types

For the RESOL module HKM2 and the corresponding controller precision temperature sensors in Pt1000 version (**FKP** and **FRP**) are used

**FK:** Weather und temperature proof silicone lines, 1,5 m in length, for temperatures from -50 °C...+180 °C, mostly used for the collector.



**FR:** PVC cable, 2,5 m in length, for temperatures between -50 °C ...+80 °C, mostly used for stores.

Make sure that all electrical works are carried out according to the relevant local and VDE-regulations. The sensor cables carry low voltages and they must not run together in a cable conduit with cables carrying higher voltages than 50 Volts. When using longer cables or cable conduits, please use shielded cables. The sensor cables can be extended up to 100 m, but the cross-section of the extended cable must be 1,5 mm<sup>2</sup> (or 0,75 mm<sup>2</sup> up to a cable length of 50 m); For longer conduits and for a use in cable conduits, cables with twisted conductors should be used preferably. The sensors must not be in direct contact with water, please always use immersion sleeves.

**Immersion sleeve:** Deliverable for different lengths (immersion depth)

FK...60: 60 mm immersion depth, brass sleeve, chromed

FK...150: 150 mm immersion depth, sleeve made of copper, chromed

Important notice: Please push the sensor entirely into the sleeve and tighten the screwing slightly.

**Cylindrical clip-on sensors:** for optional tube diameter, completed with strain relief

FK...21 or FR...21

The sensor has to be in a good contact with the conduit. Therefore please clean the contact surface thoroughly and lay on a heat conducting paste between sensor and tube. In order to protect it against ambient temperature influences please wind the sensor lines once around the tube and insulate it properly.

**Flatscrew sensors:** For installation on flat surfaces

FK...9 oder FR...9

Please pay attention to a good thermal contact.. Use a heat conducting paste and an insulation against ambient temperature influences.

### 3. Function survey

#### 3.1 Heating circuit (weather controlled):

**All settings for the HKM2 have to be adjusted with the corresponding menu of the connected controller! Please read the mounting instruction for the controller in order to use all functions for the HKM2.**

The feed flow set temperature for the heating circuit results from the ambient temperature and the chosen heating curves. This feed flow set temperature can also be changed with a remote control and the parameters „daily correction/nightly temperature lowering“. The control adjusts the current heating circuit feed flow temperature to the determined feed flow set temperature by opening/closing the heat circuit mixer.

#### 3.2 Timer (day programme):

The timer determines whether the daily correction or the nightly temperature lowering is used for changing the feed flow set temperature. If one of the time frames of the timer is „active“, the nightly temperature lowering is used. If none of the time frames is active, the feed flow set value is changed due to the daily correction. A time frame is „active“ when the current time is between the switch-on and the switch-off time.

#### 3.3 Remote controller:

The remote control enables a parallel translation of the heating curve line (+/-15K). Moreover, the heating circuit can be switched-off or a rapid heating process can be started with the remote control. The remote control is optional and not contained in the full kit.

#### 3.4 Switch-off heating circuit:

The heating circuit can be switched-off manually if.

- the remote control is set to “Heatp. off”

The heating circuit is switched-off automatically if

- the adjusted maximum feed flow temperature is reached
- the ambient temperature is higher than the adjusted summer temperature.
- the feed flow set temperature sensor is faulty.
- or the heating circuit at the controller is deactivated (permanently off)

Heating circuit switched-off means that the heat circuit pump is switched-off and the mixer is shut down.

#### 3.5 Heating circuit rapid heating-up

A rapid heating-up of the heating circuit can only be realised if the remote control is set to position „rapid heating process“.

Rapid heating-up means that the mixer is fully started-up and the heating circuit pump is switched-on. There is no regulation of the feed flow temperature. The heating circuit rapid heating-up should only be activated if the maximum feed flow temperature exceeds the current store temperature. The heating circuit will be switched-off if the maximum feed flow temperature is reached.

**3.6 Feed flow set temperature:**

The feed flow set temperature results from the measured ambient temperature and the chosen heating curve line. The correction value of the remote control as well as the daily correction or nightly temperature lowering are added to these values. The feed flow set temperature = heating curve line temperature + remote control + (daily correction or nightly temperature lowering). If the calculated feed flow set temperature is higher than the adjusted maximum feed flow temperature, the feed flow set temperature is equated with the maximum feed flow temperature.

**3.7 Mixer regulation:**

The mixer regulation is used for aligning the feed flow temperature with the feed flow set temperature. For this purpose the mixer is started up/shut down according to the deviation. The mixer is activated for the runtime of 4 seconds (factory setting). The pause is calculated from the set and actual value.

**3.8 Priority of domestic hot water**

This function switches-off the heating circuit during domestic hot water after-heating. For this purpose the option domestic hot water priority has to be activated and the after-heating has to be effected by the boiler charge control.

**3.9 Blocking protection for heating circuit pumps:**

The heating circuit pump is switched on every day at 12 o'clock for 30 seconds to avoid a getting stuck of the pump. This function doesn't work if the feed flow set value is reached, the feed flow sensor is damaged or the function domestic water priority is activated.

**3.10 Anti-freeze function**

If the temperature at the feed flow sensor falls below 8°C, the heating circuit is switched-on. If the feed flow temperature reaches 10°C, the heating circuit is switched-off again.

**3.11 Store after-heating (Differential controller):**

In order to start up the after-heating (abbr.: AH) of the heating circuit, the difference between the calculated feed flow set temperature and one (AH= thermal) or two store sensors (AH=boiler) is measured. If the difference between both temperatures is too low, the after-heating is activated. The after heating is switched-off if the difference between store and feed flow set temperature is high enough.

## 4. Operation and adjustment

Connect the HKM2 module via the RESOLVBus to the main controller. Activate the **HK-Module** with the corresponding menu option. From the *DeltaSol*® M version 1.10 on you can choose between „No“, „HKM1“ and „HKM2“, in the previous versions between „Yes“ and „No“. All parameters are shown on the corresponding menu (HK-Module).

### 4.1 Controller parameter and display channels

#### Channels HKM2

- **EC Error Code**  
Error Code, display channel HKM2  
0 = OK  
1 = sensor fault  
2 = Bus defect
- **VC Version Compatibility**  
System recognition of the HKM2 by the controller display channel HKM2  
0 = Bus defect  
1 = HKM1  
3 = HKM2
- **SA Sub Address**  
Subaddress for operation of VBus  
Adjustment channel HKM2
- **MM Manual Mode**  
State of the relays, only if manual control switch is set to I  
0 = R1 on, R3 on, 1 = R1 on R2 on, 2 = R1 on
- **PG ProGramme**  
Hardware version  
Display channel HKM2
- **VN VersioN**  
Software version,  
Display channel HKM2
- **FL FLOW**  
Current feed flow temperature,  
Display channel controller
- **FS Flow Set**  
Current feed flow set temperature,  
Display channel controller
- **OU Outdoor**  
Current ambient temperature,  
Display channel controller
- **S1 Store temperature 1**  
Current temperature of store sensor 1,  
Display channel controller
- **S2 Store temperature 2**  
Current temperature of store sensor 2,  
Display channel controller
- **RA Remote Adjustment**  
Adjustment of the remote control  
Display channel controller
- **S6 Sensor 6**  
Only measured value without function  
Display channel controller
- **R1 Relay 1: Heating circuit pump**  
Current state of the relay heating circuit pump  
Display channel controller
- **R2 Relay 2: Mixer on**  
Current state of the relay for starting up  
the mixer, display channel controller
- **R3 Relay 3: Mixer off**  
Current state of the relay for shutting down  
the mixer, display channel controller
- **R5 Relay 5: After-heating**  
Current state of the relay after-heating,  
display channel controller

#### 4.1.1 Temperature feed flow

SYSTEM / HEATING CIRCUITS / HK-MODULE / TFLOW  
Display range: -30,0°C ... 200,0°C

The value **temperature feed flow** indicates the feed flow temperature of the heating circuits.

#### 4.1.2 Ambient Temperature

SYSTEM / HEATING CIRCUITS / HK-MODULE / T OUTD.  
Display range : -30,0°C ... 200,0°C

The value **ambient temperature** indicates the weather-controlled ambient temperature.

#### 4.1.3 Remote control correction

SYSTEM / HEATING CIRCUITS / HK-MODULE / MANUAL-CORR.  
Display range: -15,0°K ... +15,0°K

The remote control enables a parallel translation of the heating curve line at max.  $\pm 15$  K. Furthermore, the heating circuit can be switched off by means of a remote control and it can start up the rapid heating-up. The value „remote control correction“ indicates the parallel translation of the heating curve line in Kelvin. The adjustment of the value is to be exclusively effected at the external remote control RESOL RTA11-M which has to be activated from the **DeltaSol® M** Version 1.10 on in the heating circuit / **EXPERT** menu.

#### 4.1.4 Feed flow set temperature

SYSTEM / HEATING CIRCUITS / HK-MODULE / FEED FLOW.SET  
VALUE  
Display range: 20°C ... 100°C

The value feed flow set temperature indicates the target value of the feed flow temperature. The measured ambient temperature and the chosen heating curve line result in the feed flow set temperature. The correction value of the remote controller as well as the daily correction or the nightly lowering are also added up to the feed flow set temperature..

Feed flow set temperature = heating curve line+ remote controller + (daily correction or nightly lowering).

#### 4.1.5 Store temperature 1

SYSTEM / HEATING CIRCUIT 5 / HK-MODULE /  
TST  
Display range: -30,0°C ... 200,0°C

The store temperature indicates the temperature of the store. If the temperature at the store sensor (S3) underruns the feed flow set temperature by 4 K (factory setting), the after-heating (relay 5) will be switched on.

It will be switched off again, if the temperature at the sensor S3 exceeds the feed flow set temperature by 14 K (factory setting).

#### 4.1.6 Store temperature 2

SYSTEM / HEATING CIRCUITS / HK-MODULES /  
TST2  
Display range: -30,0°C ... 200,0°C

This value won't be displayed until the option **AH=Boiler** won't be selected. The in point 4.1.5 specified switching condition is valid for both store sensors. This option enables a longer after-heating runtime.

#### 4.1.7 Nightly lowering

SYSTEM / HEATING CIRCUIT / HK-MODULE / NIGHTLY  
LOW.  
Adjustment range: -40 K ... 0 K  
Factory setting: -4 K

Adjustment channel for the nightly lowering of the heating circuit.. Up to 21 weekly timers - depending on the system - in which the feed flow set temperature is lowered by the chosen temperature difference can be used for nightly lowering.

#### 4.1.8 Daily correction

SYSTEM / HEATING CIRCUITS / HK-MODULE / DAIL. CORR..  
Adjustment range: -5 K ... 15 K  
Factory setting: 5 K

Adjustment channel for the daily correction of the heating circuit. The daily correction is always active **outside** of the three time frames of the nightly lowering. The feed flow set temperature is increased or lowered by the chosen temperature difference.

**4.1.8 Feed flow maximum temperature**

SYSTEM / HEATING CIRCUITS / HK-MODULE /  
T FEED FLOW MAX.

Adjustment range: 10°C ... 100°C  
Factory setting: 50°C

Adjustment channel for the maximum allowable feed flow temperature of the heating circuit. If the maximum feed flow temperature is exceeded the heating circuit is shut down (the mixer is shut down as well as the pump is shut down depending on the selected option).

**4.1.9 Heating curve**

Heating curve family

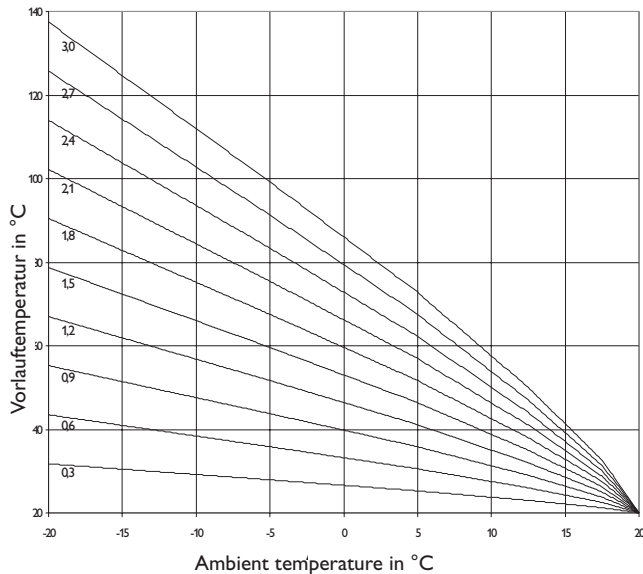

Dependency of the feed flow temperature on the ambient temperature and the chosen heating curve line (Adjustment range: 0,3 ... 3,0, factory setting: 1,0)

**4.1.10 Mixer runtime**

SYSTEMS / HEATING CIRCUITS / HK-MODULE / MIXER

Adjustment range: 1 sec.... 20 sec.  
Factory setting: 4 sec.

The mixer is started up and shut down in accordance to the deviation of the current feed flow temperature from the feed flow set temperature. The mixer is activated for 4 seconds in each case (factory setting). The pause is calculated from the deviation from the set- and actual value. This parameter conforms the mixer regulation to the manipulating time of the mixer in use.

**4.1.11 Summer operation**

SYSTEM / HEATING CIRCUITS / HK-MODULE / SUMMER

Adjustment range: 0°C ... 40°C  
Factory setting: 20°C

Adjustment channel for summer operation. If the ambient temperature exceeds the set value, the heating circuit is switched-off.

**4.1.12 Domestic hot water priority**

SYSTEM / HEATING CIRCUIT / HK-MODULE / D.H.W.  
PRIORITY

Adjustment range: Yes ... No  
Factory setting: no

This function switches-off the heating circuit during hot water-after-heating. For this purpose option domestic hot water priority and option store charge controll have to be activated at the main controller.

**4.1.13 Timer:**

SYSTEM / HEATING CIRCUITS / HK-MODULE / TIMER

Adjustment range: Mo 0.00....Sun.,11:59p.m.  
Factory setting: T. on, every day 05:00 a.m.  
T OFF: every day,10:00 p.m.

**Example:** If the nightly lowering shall start on Tuesday between 10 p.m. and 6 a.m. and 3p.m. and 6p.m., t1-on has to be set to Tue.. 10 p.m., t1-off to Tue.6 a.m., t2-on to Tue 3 p.m. and t2-off to Tue 6 p.m...  
If all time frames stop at 00:00 o'clock, the nightly lowering is deactivated, the heating circuit is at daily work for 7 days, 24 h.

The timer determines whether the daily correction or the nightly lowering is used for the adjustment of the feed flow set temperature. 21 different time frames can be adjusted for the nightly lowering of the heating circuit. If one of the adjusted time frames of the timer is 'active', the nightly lowering is used , If none of the time frames is 'active', the feed flow set temperature is equated with the daily correction. A time frame is 'active', if the current time is between the switch-on and switch-off point.

**4.1.14. HKM Expert**

(from DeltaSol® M SW-Version 1.10 on)

*ΔTRAH ON***Switch-on temperature difference****After-heating (After-heating = therm. or boiler)***SYSTEM / HEATING CIRCUIT / HK-MODULE /**HKM EXPERT / ΔTNH ON*

Adjustment range: -15 K... 50 K

Factory setting: 4 K

If the temperature at the store sensor (S1, AH=Thermo) or at both store sensors (S1 und S2, AH=Boiler), as the case may be, underruns the feed flow set temperature by the value  $\Delta TRAH ON$ , the after-heating (Relay 5) is switched on

*ΔTNH OFF***Switch-off temperature difference****(After-heating=therm. or boiler)***SYSTEM / HEATING CIRCUIT / HK-**MODULE / HKM EXPERT / ΔTNH OFF*

Adjustment range: -15 K... 50 K

Factory setting: 4 K

The after-heating switches off if the temperature at the store sensor (S1, NH=Thermo) or both store sensors (S1 und S2, NH=Boiler) exceeds the feed flow set temperature exceeds by the value  $\Delta TNH OFF$ .

**After-heating***SYSTEM / HEATING CIRCUIT / HK-MODULE / HKM EXPERT**/ AFTER-HEATING*

Adjustment range: No therm., Boiler

Factory setting: None

Here the weather-controlled store after-heating can be activated. Select adjustment *THERM.* (function refers to S1) or *BOILER* (function refers to S1 and S2). With the adjustment *NONE* the function will be deactivated.

*MANUAL-CORR.***Remote Control***SYSTEM / HEATING CIRCUITS / HK-MODULE / HKM EXPERT / MAN-**CORR.*

Adjustment range: Yes...No

Factory Setting: No

With the connection of a RTA11-M remote control, this one here has to be activated (Adjustment: *YES*).

*PUMP HCMAX***Performance of the heating circuit pump when exceeding the feed flow maximum temperature***SYSTEM / HEATING CIRCUIT / HK-MODULE / HKM EXPERT / PUMP**HKMAX*

Adjustment range: On...Off

Factory Setting: Off

If the maximum feed flow temperature is reached, the heating circuit pump is switched off with the adjustment *OFF*. With the adjustment *ON* the heating circuit pump continues. (Only the mixer will be shut down).

### 4.1.15 Manual operation

Adjustment range: 0, Auto, I  
 Factory setting: Auto



The heating circuit and the heating circuit pump can be switched on or off manually with the manual control switch. In order to operate the HKM module at full capacity the manual control switch should be set to “Auto“. With the help of parameter MM the relays can be switched in different states : **MM0** = R1 on, R3 on, **MM1** = R1 on, R2 on, **MM2** = R1 on

### 4.1.16 LED - Blinking Codes

**Constantly green:** OK  
**Blinking red:** Error  
 Sensor fault

## 5. Commissioning

Please connect the power supply at first. The HKM2 module passes through an initialisation phase during which the operating control lamp is blinking.

Afterwards the module switches to the normal mode and indicates the feed flow temperature FL and the feed flow set temperature FS.

## 6. Tips for fault localization

If the heating circuit module doesn't work faultlessly, please check the following points:

### 1. Power supply

If the operating control lamp is off, please check the power supply of the controller.

The HKM2 is protected by a one can fuse T4 A which is accessible and can be replaced by opening the cover of the housing (spare fuse is enclosed in one of the accessory bags).

### 2. Manual control switch

For faultless use of the control of the HKM2 module the manual control switch should be set to “Auto“.

### 3. Sensor faults

If there is a malfunction due to a sensor defect, it is signalled by the operating control lamp flashing red and symbol being displayed. An error code for the affected sensor is shown on the display. For checking the 3rd temperature sensor the pushbutton 1 must be pressed ONCE.

**Short-circuit:** Short-circuit in the sensor conductor with indication of the affected temperature sensor. Error code -888.8 for this sensor is shown on the display.

**Line break:** Interruption of the sensor conductor with indication of the affected temperature sensor. Error code 888.8 for this sensor is shown on the display.

Clamped Pt1000-temperature sensors can be checked with a resistance-measuring device. The measured temperatures can be compared to the resistance values shown on the table. opposite

°C	Ω	°C	Ω
-10	961	55	1213
-5	980	60	1232
0	1000	65	1252
5	1019	70	1271
10	1039	75	1290
15	1058	80	1309
20	1078	85	1328
25	1097	90	1347
30	1117	95	1366
35	1136	100	1385
40	1155	105	1404
45	1175	110	1423
50	1194	115	1442

Resistance values of the Pt1000-sensors

## 6. Tips for fault localization

Description of symptoms	Possible causes / Solution
Heater is constantly on	<ul style="list-style-type: none"> <li>- Please check if function „rapid heating process“ at the remote control is activated?</li> <li>- Ambient temperature sensor is not accurately-positioned or faulty? (see „sensor faults“)</li> <li>- Temperature value for summer activity is set too high?</li> </ul>
Heater is constantly off	<ul style="list-style-type: none"> <li>- Please check if function „heating circuit off“ at the remote control is activated?</li> <li>- pump is set to „0“ at the HKM2 (Off)?</li> <li>- Feed flow sensor fault? (see „sensor faults“)</li> <li>- Temperature value for summer activity is set too low?</li> </ul>
Heater heats very slowly	<ul style="list-style-type: none"> <li>- Adjusted value for mixer runtime is too low?</li> </ul>
In spite of heating pauses, it is constantly too warm	<ul style="list-style-type: none"> <li>- Please check the adjusted heating curve, lower it if necessary.</li> <li>- Feed flow maximum temperature is too high? Lower it if necessary.</li> <li>- Please check the position of the remote control, choose a 'lower' position if necessary.</li> <li>- Adjusted value for daily correction too high? Lower it if necessary.</li> </ul>
In spite of an active heater, it is constantly too cold	<ul style="list-style-type: none"> <li>- Adjusted heating curve line too low? Raise it if necessary.</li> <li>- Feed flow maximum temperature is too low? Raise it if necessary.</li> <li>- Please check the settings of the remote control.</li> <li>- Please check the adjusted time.</li> <li>- Please check the adjustments of the time frames for the nightly correction in order to prevent an unintended temperature drop.</li> </ul>

## Notes

---

### RESOL - Elektronische Regelungen GmbH

Heiskampstraße 10  
D - 45527 Hattingen

Tel.: +49 (0) 23 24 / 96 48 - 0  
Fax: +49 (0) 23 24 / 96 48 - 55

[www.resol.de](http://www.resol.de)  
[info@resol.de](mailto:info@resol.de)

### Distributed by:



### Comments:

The design and the specifications can be changed without advance notice.  
The illustrations can differ from the production model