

RESOL DeltaSol® Pool

Mounting

Connection

Operation



48004110

Thank you for buying this RESOL product.
Please read this manual carefully to get the best performance from this unit.

DeltaSol® Pool



Manual

www.resol.de

Safety advice

Please pay attention to the following safety advice in order to avoid danger and damage to people and property.

Appropriate usage

This product is to be used in solar thermal systems in compliance with the technical data specified in these instructions (see p. 3).

Improper use excludes all liability claims

Instructions:

Attention should be paid to

- valid local regulations
- the statutory provisions for prevention of industrial accidents,
- the statutory provisions for environmental protection,
- the Health and Safety at Work Act 1974
- Part P of the Building Regulations 2005
- BS7671 Requirements for electrical installations and relevant safety regulations of DIN, EN, DVGW, TRGI, TRF and VDE.

These instructions are exclusively addressed to authorised skilled personnel.

- Only qualified electricians should carry out installation and maintenance work.
- Initial installation should be carried out by named qualified personnel

Subject to change without notice.
Errors excepted

Table of contents

Safety advice	2
Overview of functions and technical data	3
1. Installation	4
1.1 Mounting.....	4
1.2 Electrical connection.....	4
1.2.1 Overview of electrical connections.....	4
1.2.2 Actuators.....	5
1.2.3 Data communication / bus.....	5
1.2.4 Sensors.....	6
1.2.5 Mains supply.....	6
2. Basic system	7
2.1 Sensor allocation.....	7
2.2 Relay allocation.....	7
3. Operation and function	8
3.1 Buttons for adjustment.....	8
3.2 Control lamp.....	8
3.3 Menu structure.....	9
3.4 User code.....	9
3.5 Menu overview.....	10
4. Commissioning	11
5. Functions and options	11
6. Messages	16
7. Balance values	18
8. Troubleshooting	18
10. Accessory	20
Imprint	22

Declaration of conformity

We, RESOL Elektronische Regelungen GmbH, D-45527 Hattingen, declare under our sole responsibility that our product DeltaSol® Pool complies with the following standards:

EN 55 014-1

EN 60 730-1

According to the regulations of the above directives, the product is labelled with **CE**:

89/336/EWG

73/ 23/EWG

Hattingen, 07.07.2006

RESOL Elektronische Regelungen GmbH,

ppa. G. Neuse

ppa. Gerald Neuse

- controller for heating a swimming pool by means of solar absorbers in combination with the optimised operation of the filter system
- solar operating hours counter and heat quantity measurement
- 13 sensor inputs
- 7 relay outputs
- function control
- RESOL VBus®



Scope of delivery:

- 1 x DeltaSol® Pool
- 1 x accessory bag
 - 2 x screws and dowels
 - 8 x strain relief and screws
 - 1 x capacitor 4,7 nF

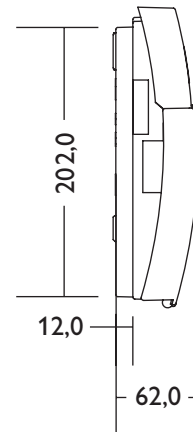
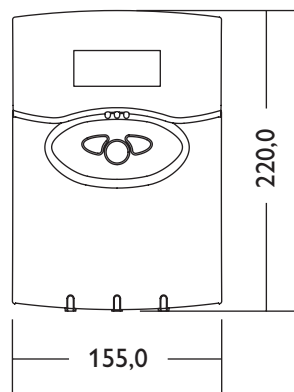

Technical data

Housing: plastic, PC-ABS and PMMA

Protection type: IP 20 / DIN 40 050

Ambient temperature: 0...40 °C

Dimensions: 220 x 155 x 62 mm

Mounting: wall mounting, mounting into patch panels is possible

Display: 4-line LCD text display

Operation: 3 push buttons at the front

Functions: controller for heating a swimming pool by means of solar absorbers in combination with the optimised operation of the filter system. Add-on afterheating of the swimming pool depending on the need and on the power of the solar absorbers.

Solar loading:

When the absorber temperature is by an adjusted value higher than the pool

temperature, solar loading starts. If the difference between flow and pool falls below a certain value, or if the maximum temperature is reached, solar loading is stopped.

Sensor inputs: 10 sensor inputs for Pt1000, 1 x CS10, 1 x IMP and 1 digital input

Relay output: 7 relay output, 1 of them floating

Bus: VBus®

Power supply: 115V~

Switching capacity:

2 (1) A (115) V~
(standard relay)

4 (1) A (115) V~
(potential-free relay)

Rated impulse voltage: 2,5 kV

Mode of operation:

type 1.b / type 1.y

Degree of pollution: 2



Attention: Electrostatic discharge can cause damage of electronic components



Warning: high-voltage components

1. Installation

1.1 Mounting

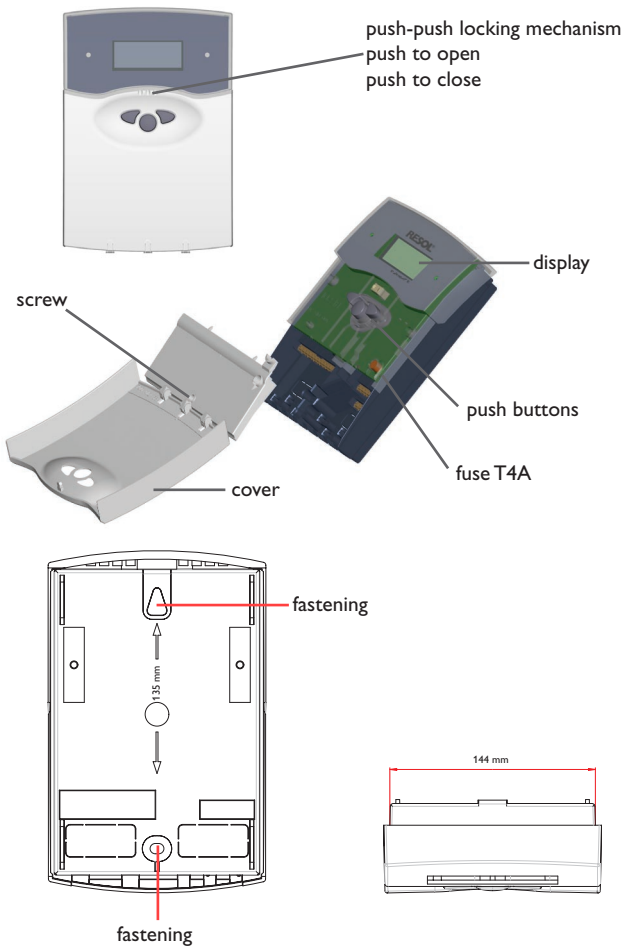

WARNING!

Always disconnect the controller from power supply before opening the housing!

The unit must only be located in dry interior locations. It is not suitable for installation in hazardous locations and should not be placed close to any electromagnetic fields. The controller must additionally be supplied from a double-pole switch with contact gap of at least 3 mm. Please pay attention to separate routing of sensor cables and mains cables.

1. Open the front cover by pushing it. Unscrew the cross-head screw from the cover and remove it along with the front cover from the housing.
2. Mark the upper fastening point on the wall and drill and fasten the enclosed wall plug and screw leaving the head protruding.
3. Hang the housing from the upper fastening point and mark the lower fastening point through the hole in the terminal box (centres 135 mm). Drill and insert the lower wall plug.
4. Hang the housing from the upper fastening point and attach with the lower screw.
5. Carry out connection in accordance with the terminal allocation.
6. Insert cover and attach with the cross-head screw. Close the front cover properly.

1.2 Electrical connection

1.2.1 Overview of electrical connections

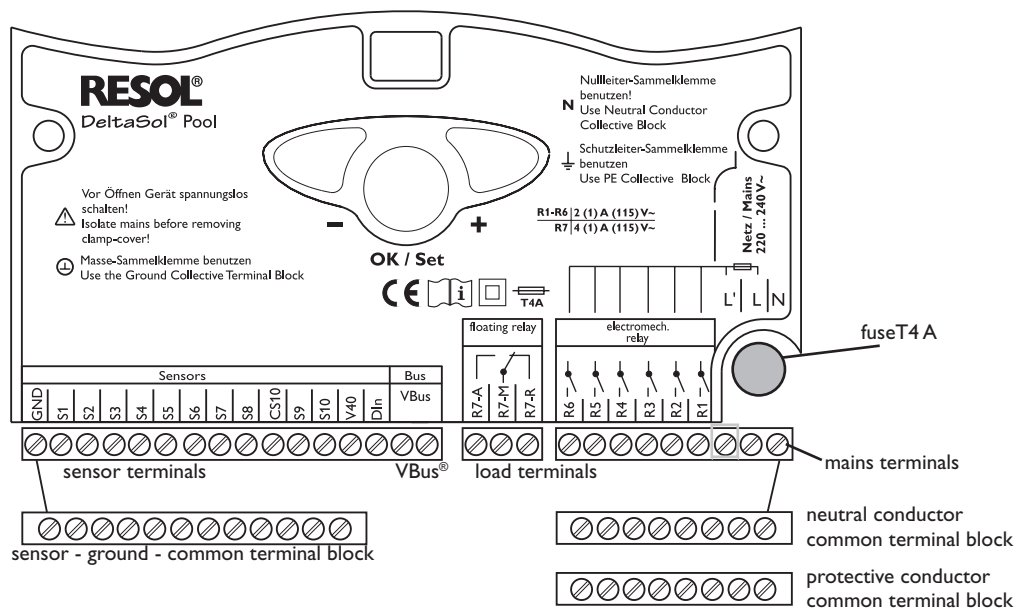

1.2.2 Actuators

(pumps, valves, etc.)

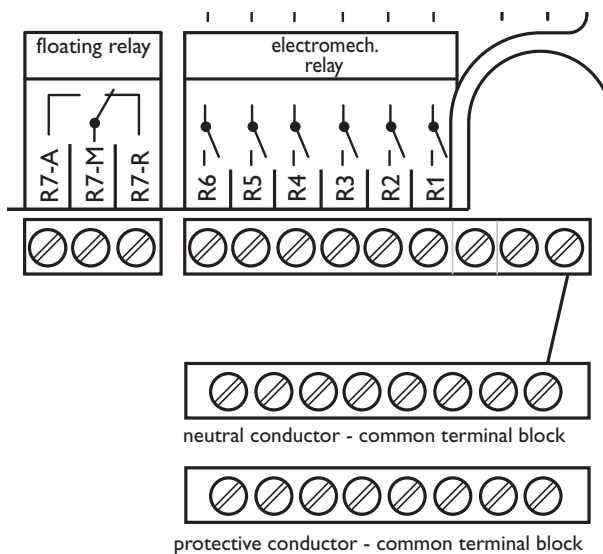

The controller is equipped with 7 relays to which **loads** (actuators) such as pumps, valves and auxiliary relays can be connected:

- **Relays R1 ...R6** are electromechanical relays with 1 normally open contact:
 R1 ...6 = normally open R1 ...R6
 N = neutral conductor N (common terminal bloc)
 PE = protective conductor PE (common terminal bloc)
- **Relay R7** is a potential-free (floating) relay with change-over contact:
 R7-M = center contact R7
 R7-A = normally open R7
 R7-R = normally closed R7

1.2.3 Data communication / bus

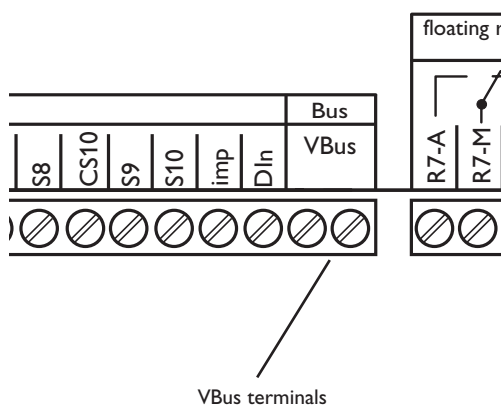

The controller is equipped with the RESOL VBus® for data transfer with and energy supply to external modules. The connection is carried out at the two terminals marked "VBus®" (either polarity). One or more RESOLVBus® modules can be connected via this data bus:

- RESOL WMZ calorimeter
- RESOL large display
- RESOL Datalogger

1.2.4 Sensors

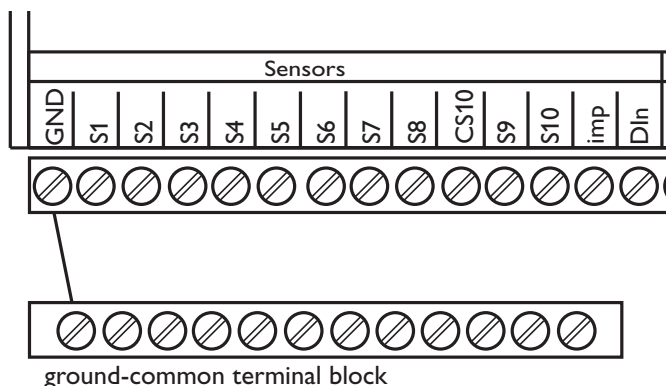

The controller is equipped with 13 sensor inputs in total. The ground connection for the sensors has to be carried out via the ground terminal block (GND).

- **Temperature sensors** have to be connected to the terminals S1 ... S10 and GND (either polarity).
- The **irradiation sensor (CS10)** is to be connected to the terminals CS10 and GND with correct polarity. Connect the terminal GND of the sensor to the terminal GND of the controller (ground terminal block), and the terminal CS of the sensor to the terminal CS10 of the controller.
- A flowmeter can be connected to the terminals Imp and GND (either polarity).
- An external message signal can be connected to the digital input Din. When the signal contact closes the input Din, the message „!message ext.“ is generated. This signal is treated like an error, which means that the control lamp flashes red and the message relay is possibly energised.

1.2.5 Mains supply

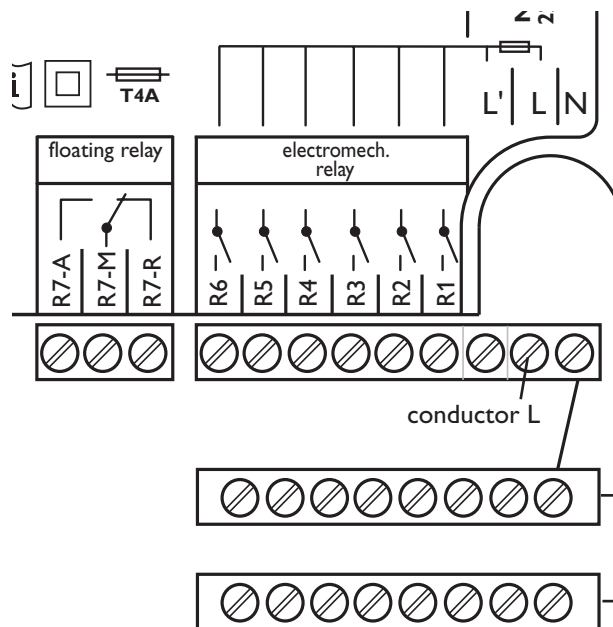

The power supply to the controller must be carried out via an external power switch (last step!) and the supply voltage must be 115 V~ (50 ... 60 Hz). Flexible cables must be attached to the housing with the enclosed strain relief and the corresponding screws or be run into the controller housing in a cable conduit or trunking.

2. Basic system

Sensor allocation

S1	S2	S3	S4	S5	S6	S7	S8	CS10	S9	S10	Imp	Din
T-absorber	T-pool	T-flow	T-outd.	T-return (WMZ)				irradiation			flow rate	release filter system switch-extra filter runtime

Abbreviations sensors

sensor	description
T-absorber	absorber temperature
T-pool	swimming pool temperature
T-flow	flow temperature
T-outd.	outdoor temperature
T-return	return temperature
irradiation	solar irradiation
flow rate	flow rate

Relay allocation

R1	R2	R3	R4	R5	R6	R7
filter pump	pump (P2) afterheating	signal relay	operating relay	valve (V1) open (solar pump)	valve (V1) closed	demand afterheating potential-free

Abbreviations - relays

relay	description
R1	filter pump
R2	pump (P2) afterheating
R3	signal relay
R4	operation
R5	valve (V1) open (solar pump)
R6	valve (V1) closed
R7	afterheating demand potential-free

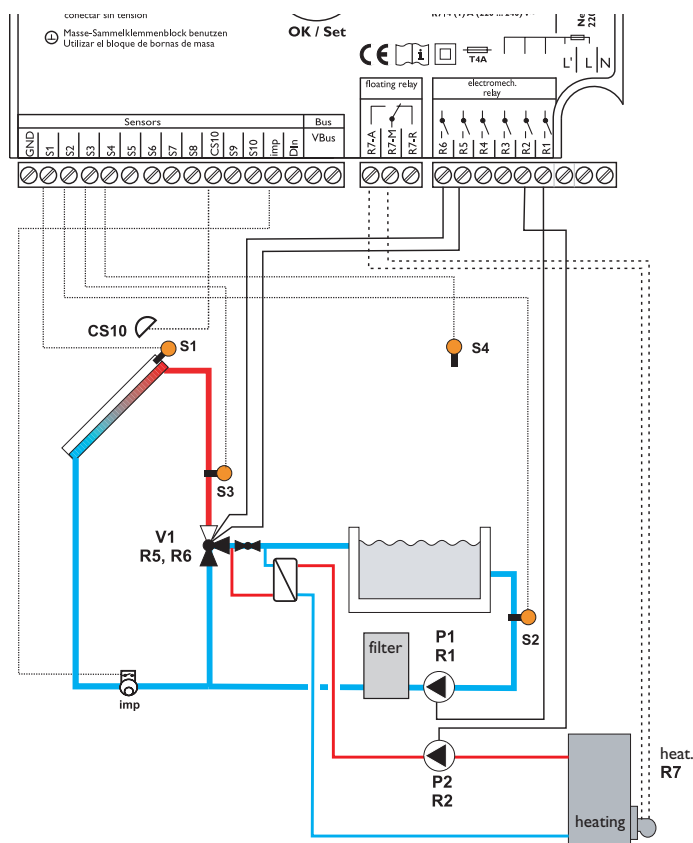

3. Operation and function

3.1 Buttons for adjustment

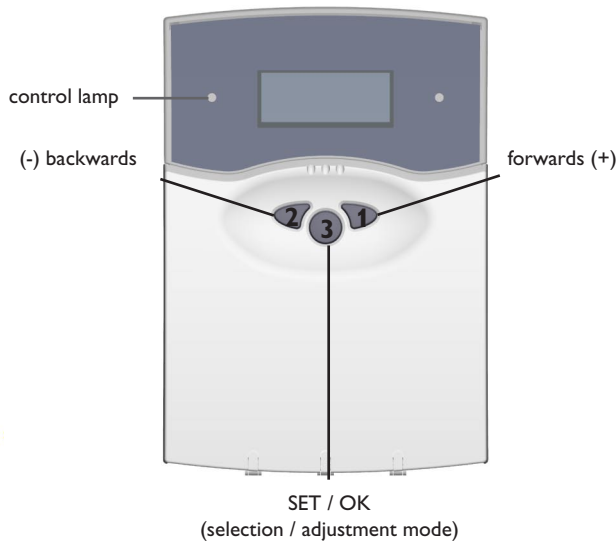

The controller is operated via the 3 push buttons below the display. The forward-button (1) is used for scrolling forward through the menu or to increase the adjustment values. The backward-button (2) is similarly used for scrolling backwards and reducing values. Button 3 is used for selection of the menu lines and for confirmation.

- Briefly press button 3 in order to get to the main menu
- Select the requested menu using buttons 1 and 2.
- Briefly press button 3, the selected submenu is then shown on the display. By selecting the menu line „back“, the display returns to the former menu level.
- Press buttons 1, 2 and 3 to scroll until the chosen menu line is reached.
- Briefly press button 3 in the respective menu line to modify adjustment values, adjust the requested value by pressing the buttons 1 and 2 (for large intervals, keep the button pressed).
- Briefly press button 3 in order to finish the adjustment.
- To save the change, answer the security inquiry „Save?“ by choosing „yes“ or „no“ (buttons 1 and 2) and confirm with button 3.
- **When button 3 is pressed for 2 seconds, the display changes back to the main menu.**

3.2 Control lamp

The controller is equipped with a red-/green control lamp. The following control and system status are signalled:

- green: automatic operation
- red flashing: malfunction of the system
- green flashing: manual mode

3.3 Menu structure

	Mainmenu
1.	Status
2.	WMZ
3.	Balances
4.	Manualoperation
5.	Adj.values
6.	User code
7.	Expert

The clear-text display shows a 4-line part of the selected menu.

Adjustment and control of the controller are carried out via the menu. When the controller is commissioned, the display level is in the status menu. In the first line of each submenu you will find the option “back”, by means of which it is possible to get to the former menu level. In the following diagrams you will find the complete menu contents; since some of the menu points depend on the system, option or message, in some cases not all of the shown text lines are indicated.

STATUS is shown on the display in the initial state. A selection can be made between 7 submenus.

Note:

The choice of adjustment values and options depends on different functions and the user code. Some only appear in the display if they are available for the adjusted system parameters.

3.4 User code

1. Expert **Code 0077**
All menus and adjustment values are shown and all values can be altered.

Note:

After the menu point “user code” has been chosen, enter the user code!

If you do not enter the expert user code, the expert menu will not be displayed.

3.5 Menu overview

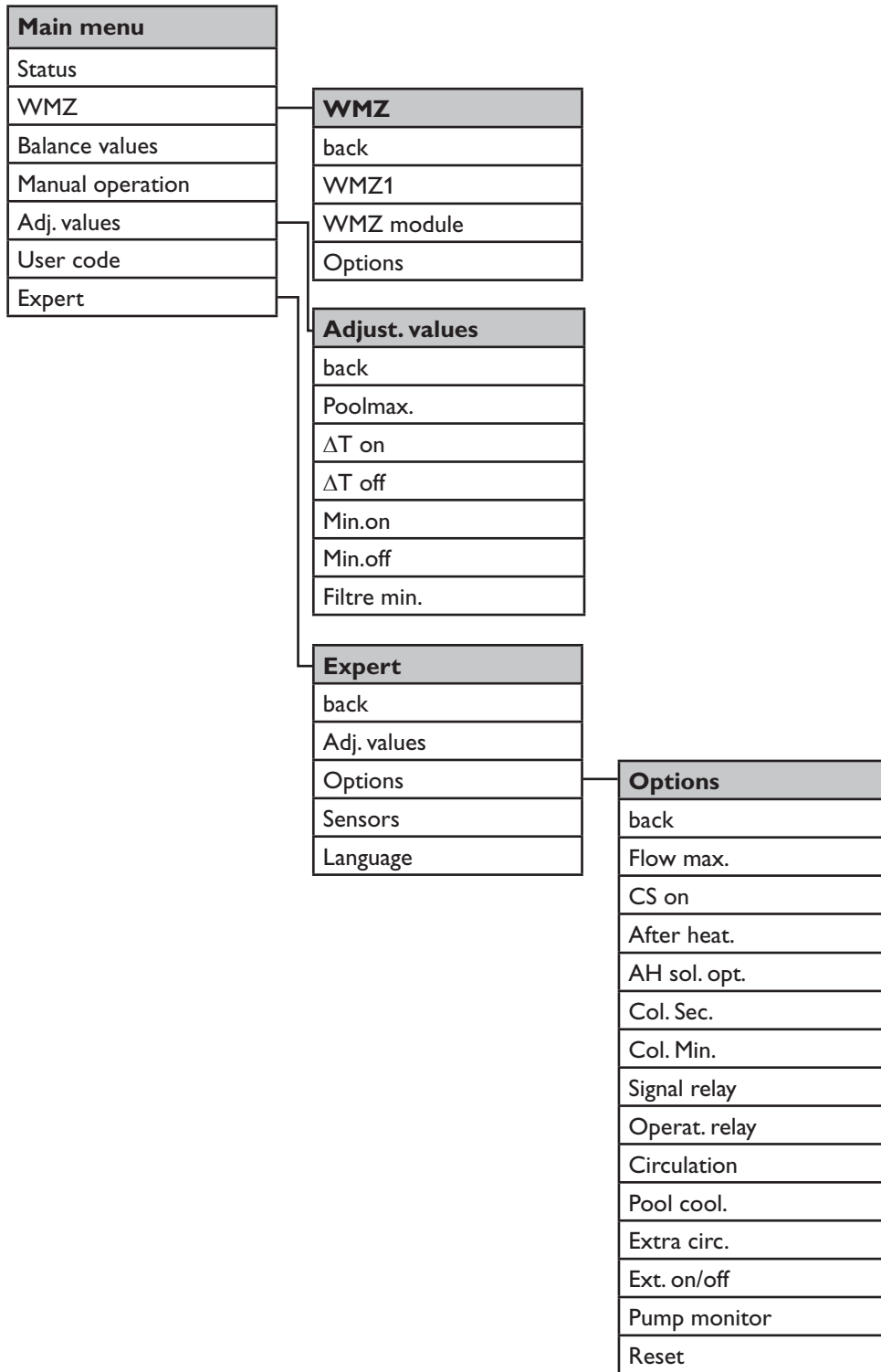

4. Commissioning

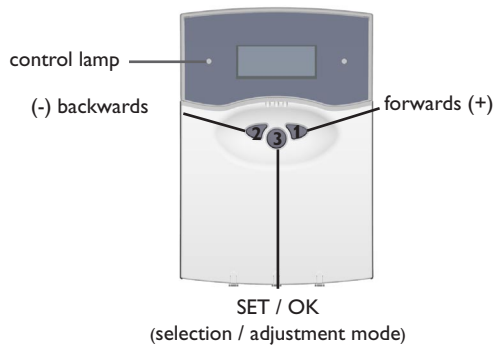

Adjust date and time in the **Status** menu.

5. Functions and options

Maximum pool temperature

Adj.values/Poolmax.
adjustment range: 10,0 ... 40,0 °C
factory setting: 30,0 °C

Adjust the maximum pool temperature, in °C.

When the adjusted swimming pool temperature is reached, the solar system switches off. The circulation function will not be suppressed.

Switch-on difference

Adj.values/ΔTon
adjustment range: 3,5 ... 20,0 K
factory setting: 5,0 K

Adjust the switch-on difference for the solar circuit, in Kelvin.

Switch-off difference

Adj.values/ΔToff
adjustment range: 0,5 ... 19,5 K
factory setting: 3,0 K

Adjust the switch-off difference, in Kelvin. The switch-off difference must be by at least 0,5 K smaller than the switch-on difference ΔTon.

Minimum runtime

Adj.values/Min.on
adjustment range: 1 ... 10 min
factory setting: 2 min

Adjust the minimum runtime, in minutes.

Period of time during which the system has to run at least after the switch-on condition has been fulfilled. The minimum switch-on will not be interrupted by the swimming pool maximum temperature limitation.

Minimum break time

Adj.values/Min.off
adjustment range: 1 ... 10 min
factory setting: 2 min

Adjust the minimum break time, in minutes.

Period of time during which the system has to stand still at least after the switch-off condition has been fulfilled.

Minimum filter runtime

Adj.values/Circ.min.
 adjustment range: 0 ... 16 h
 factory setting: 5 h

Adjust the minimum runtime of the filter pump, in hours.

The pump will be switched on every day for this period of time. This adjustment value is variable and has to be passed through until the reference point (07:00 p.m.).

Example: When the filter runtime is adjusted to 5 hours, the filter pump has to start at 02:00 p.m. and continuously run until 07:00 p.m.

The minimum filter runtime will also be maintained in the case of a sensor fault.

Switch-on delay

Expert/Adj.values/t-ΔTon
 adjustment range: 0 ... 300 s
 factory setting: 20 s.

Adjust the ΔTon time.

The switch-on condition has to be fulfilled for this period of time for solar loading to start.

Flow maximum limitation

Expert/Options/Flowmax.
 and adjust:
 Expert/Adj.values/T-FLmax.
 adjustment range: 30 ... 90 °C
 factory setting: 40 °C
 Expert/Adj.values/ΔT-FLsec.
 adjustment range: 0,2 ... 10,0 K
 factory setting: 2,0 K

Adjust the maximum limitation of the flow.

If this function is activated, solar loading is stopped when the maximum flow temperature has been exceeded. The pool will be loaded again, if the flow temperature falls by ΔT flowmax. below the maximum flow temperature.

The adjustable minimum difference between switch-on temperature and switch-off temperature (hysteresis) avoids that the controller switches on and off again at too low temperature differences.

Manual operation

Manual operation/All relays
 or:
 Manual operation/Relay1 etc

Each relay can be set into on-/off-/or automatic mode. During normal operation the relay is in automatic mode.

CS

Expert/Options/CSon
 and adjust:
 Expert/Adj.values/CSon
 adjustment range: 100 ... 700 W/qm
 factory setting: 300 W/qm

The pool will be loaded if the adjusted irradiation threshold (CS-Bypass) at the irradiation sensor is exceeded or if there is a temperature difference caused by high absorber temperatures. „CS on“ can be activated; the irradiation threshold is adjustable (100-700 W/m²).

Heat quantity measurement

WMZ/Options/WMZ
 selection:
 WMZ „Yes“ or „No“

Heat quantity measurement is possible with the difference between flow and return temperature, and with the flow rate indicated by the flowmeter.

If „WMZ“ is selected, flow temperature, return temperature, flow rate and heat quantity will be displayed.

WMZ/WMZ module „Yes“ or „No“

It is possible to use an additional WMZ module. Flow temperature, return temperature, flow rate and heat quantity will also be displayed.

WMZ/WMZ1/Expert

WMZ/WMZ1/Expert/Sen.flow
adjust to „3“

WMZ/WMZ1/Expert/Sen.return
adjust e.g. to „5“

Heat quantity measurement with and without flowmeter

WMZ/WMZ1/Expert/Flowmeter
selection „Yes“

WMZ/WMZ1/Expert/Vol/puls.
adjustment range: 0,5 ... 100,0 l
factory setting: 1,0 l

WMZ/WMZ1/Expert/Flowmeter.
selection „No“
WMZ/WMZ1/Expert/Relay

Antifreeze type

WMZ/WMZ1/Expert/Antifreeze type
adjust e.g. to „1“

Adjusting the antifreeze concentration

WMZ/WMZ1/Expert/Antifreeze
adjustment range: 20 ... 70 Vol %
factory setting: 40 %

Afterheating

Expert/Options/After heat.
and adjust to:

Expert/Adj.values/AH on
adjustment range: 10 ... 39,7 °C
factory setting: 24 °C

Expert/Adj.values/AH off
adjustment range: 24,3 ... 40,0 °C
factory setting: 24,5 °C

If you select the „Expert“ submenu, you can further choose between:

- Sensor flow/return: here you can re-allocate the sensors, if you do not use the sensors which have already been pre-allocated.

If a flowmeter is used („Yes“), a pulser is used for measuring the flow rate.

- Adjust volume/pulse (in l)

When no flowmeter has been selected („No“), a flow rate value has to be entered as well as the relay which is to be used for the heat quantity measurement.

- Antifreeze type:

- 0 for water;
- 1 for propylene glycol;
- 2 for ethylene glycol;
- 3 for Tyfocor LS®

Adjust the ratio of the water/glycol mixture.

When the temperature falls below the minimum temperature (AH on), afterheating is switched on and heats the pool until it reaches the desired temperature (AH off).

The value „AH on“ has to be by 0,3 K smaller than the value „AH off“.

Afterheating optimisation

Expert/Options/AHsol.opt.
and adjust:

Expert/Adj.values/AHsol.on
adjustment range: 2,0 ... 20,0 K
factory setting: 2,0 K

Expert/Adj.values/AHsol.off
adjustment range: 1,0 ... 19,7 K
factory setting: 1,5 K

Expert/Adj.values/ Δ TAH.Solar
adjustment range: 0,3 ... 20,0 K
factory setting: 1,0 K

The function starts when the pool is being loaded. Solar loading means that pool loading is only carried out for energy supply and not for cooling purposes etc.

Afterheating is suppressed when the temperature difference between flow and pool (AH solar on) is reached. If the temperature difference falls below the value „AH solar off“, the optimisation function switches off.

The adjustable minimum difference between switch-on temperature and switch-off temperature (hysteresis) avoids that the controller switches on and off again at too low temperature differences.

Circulation function

Expert/Options/Circulation
and adjust:

Expert/Adj.values/Circ.time
adjustment range: 1 ... 10 min
factory setting: 1 min

Expert/Adj.values/Circ.start
factory setting: 07:00

Expert/Adj.values/Circ.stop
factory setting: 19:00

When the solar thermal system has been off for 1 hour, it is switched on for 1 ... 10 minutes (the water of the swimming pool circulates through the pipes; this allows the pool temperature to be detected during system standstill). If the flow emergency shutdown is active, the circulation function is suppressed.

Adjust the circulation runtime, in minutes.

Beginning and end of circulation (clock time).

Absorber emergency shutdown

Expert/Options/Abs.max.

and adjust to:

Tcol.sec.
adjustment range: 60 ... 160 °C
factory setting: 130 °C

Δ Tcol.sec.
adjustment range: 2 ... 50 K
factory setting: 10 K

Absorber emergency shutdown temperature, adjustable between 60 and 160°C.

If the adjusted temperature threshold (Tcol. sec.) is exceeded, the pool will no longer be loaded by the absorber.

The adjustable minimum difference between switch-on temperature and switch-off temperature (hysteresis) avoids that the controller switches on and off again at too low temperature differences.

Absorber minimum limitation

Expert/Options/Abs.min.

and adjust:

Expert/Adj.values/TColmin
adjustment range: -25 ... 90 °C
factory setting: 10 °C

Expert/Adj.values/ Δ TColmin
adjustment range: 0,3 ... 10 K
factory setting: 5,0 K

This function makes sure that solar loading will start only if the absorber temperature reaches the adjusted value.

The adjustable minimum difference between switch-on temperature and switch-off temperature (hysteresis) avoids that the controller switches on and off again at too low temperature differences.

Pool cooling function

Expert/Options/Poolcool.

and adjust:

Expert/Adj.values/ ΔT -Cool.

adjustment range: 0,5 ... 10,0 K

factory setting: 2,0 K

Expert/Adj.values/ ΔT Coolon

adjustment range: 1,8 ... 10,0 K

factory setting: 3,0 K

Expert/Adj.values/ ΔT Cooloff

adjustment range: 0,3 ... 9,7 K

factory setting: 1,5 K

If the maximum pool temperature is exceeded by the adjusted value (ΔT -Cool), heat is diverted, provided that the absorber is by at least ΔT Cool on colder than the pool. Cooling is switched off when the value ΔT Cool Off is reached.

The adjustable minimum difference between switch-on temperature and switch-off temperature (hysteresis) avoids that the controller switches on and off again at too low temperature differences.

Filter pump monitoring

Expert/Options/Pumpmonitor

selection „Yes“ or „No“

When flowmeter is used and when the the filter pump is switched on, this option monitors whether there is a flow rate in the solar circuit. If the controller does not receive any pulse after 2 minutes, the filter pump will be switched-off and an error message will be generated.

Extra filter runtime

Expert/Options/Extracirc.

and adjust:

Expert/Adj.values/Extracirc.

adjustment range: 1 ... 20 h

factory setting: 2 h

This option is used for switching on an extra runtime of the filter pump (in h) if necessary (e.g. in the case of polluted pool water).

As soon as a contact is detected at the Din input, the filter pump starts and remains switched-on for the adjusted period of time (extra runtime). The filter minimum runtime will not be influenced by this function.

External release

Expert/Options/Ext.on/off

The external release function is used for releasing the pump for solar loading (e.g. for preventing the controller from switching on the pump during pump maintenance.) The Din input must be closed to deblock the controller (solar loading, afterheating).

Sensors:

Expert/Sensors

Expert/Sensors/CS-type

Expert/Sensors/CSadjust

Expert/Sensors/CSoffset

Expert/Sensors/Sensor1etc.

Adjust the sensor type for the solar irradiation sensor (A to E).

Adjust the sensor offset.

An offset (-5K ... +5K, in 0,1 K steps) can be allocated to each sensor in order to match the sensors with each other.

Operating relay:

Expert/Options/Operat.relay

selection: „Yes“ or „No“.

The operating relay option can be selected. If the operating relay is selected („Yes“), it is energised when the pool is being loaded.

Reset:

Expert/Options/Reset
selection: „Yes“ or „No“.

The reset option can be selected. When the reset option is selected („Yes“), the controller settings are set back to the factory settings.

Language:

Expert/Language/English

Language choice: German, English, French, Castellano, Italiano.

6. Messages

Sensor fault

!Sensor faulty
>Absorber

In the case of a sensor fault, an error message is generated:

Sensor defective.

Furthermore, the defective sensor will be recognised (absorber sensor, pool sensor or flow temperature sensor).

Signal relay (error message)

Expert/Options/Signalrelay

!Sensor faulty
!Pump
!RTC
!EEPROM

This function is switched on (option WMZ), when the controller detects a fault. In this case, the signal relay is energised (e.g. for signal lights).

These errors are:

- sensor defective
- pump defective
- real-time-clock (RTC) defective
- storage module (EEPROM) defective

Please note that a message caused by one of the plausibility controls does not activate the relay.

Messages

The following states can be displayed:

display	description
EverythingOK	normal operation of the system, no malfunction
Controlleroff	controller is switched off
>Contr.ext.off	controller has been switched off by the operator
!Pumpfaulty!	pump is defective
!Sensorfaulty	sensor is defective
>Absorber	identification of the defective sensor
>Pool	see above.
>Flow	see above
WMZoff	WMZ (heat quantity measurement) is deactivated
!Sensorfaulty	sensor is defective
>Flow	identification of the defective sensor
>Return	see above
!EEPROM	EEPROM defective
!RTC	RTC defective
Solaron	solar loading is active
Solaroff	solar loading is switched off
Min.on	minimum runtime is active
Min.off	minimum break time is active
SolarCSon	CS irradiation sensor option is active
SolarPoolmax.	maximum swimming pool temperature has been reached
SolarFlowmax.	flow emergency shutdown is active
SolarCooling	cooling is active
Circ.on	filter pump is switched on
Circ.off	filter pump is switched off
Circ.min.on	filter pump minimum runtime is activated
Circulation	circulation option is activated
Circ.time	indication of the filter pump runtime
AHon	afterheating option is activated
AHoff	afterheating option is deactivated
Afterheat.on	afterheating is active
Afterheat.off	afterheating is not active
Afterheat.Solar	afterheating is active during solar loading
TAbsor.	display of absorber temperature
Tpool	display of pool temperature
Tflow	display of flow temperature
Toutd.	display of outdoor temperature
Intens.	display of irradiation intensity
Relays	display of the individual relay status
Sensors	display of the temperatures at each sensor
Time	
Date	
Version1.00	

7. Balance values

Balance values

The values shown on the left can be balanced.

Balance/Poolmax

Balance/Colmax

Balance/Flowmax

Balance/B-rel1

Operating hours of the individual relays.

Balance/B-rel2

Balance/B-rel3

Balance/B-rel4

Balance/B-rel5

Balance/B-rel6

Balance/B-rel7

Balance/Oper.days

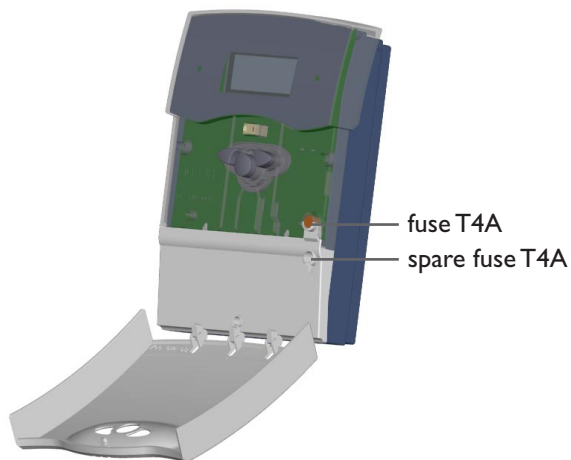

8. Troubleshooting

The defective sensor (swimming pool sensor, flow temperature sensor, absorber sensor) is indicated on the display. The solar thermal system will be switched off or not put into operation.

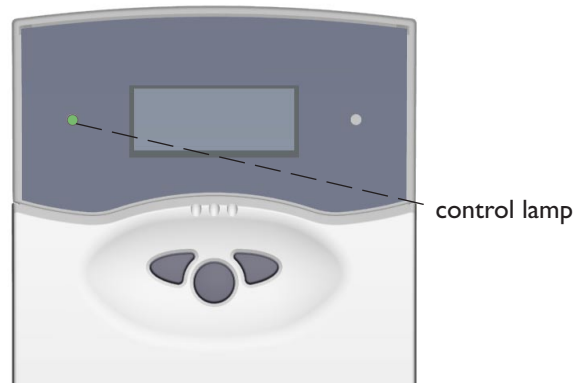

In the case of a malfunction, a message is shown on the display of the controller.



Operating control lamp flashes red. The symbol  and the  are shown.

Sensor fault. An error code instead of a temperature is shown on the sensor display channel.

888.8

- 88.8

Cable is broken. Check the cable.

Short-circuit. Check the cable.

Disconnected Pt1000 temperature sensors can be checked with an ohmmeter. In the following table, the resistance values corresponding to different temperatures are listed.

°C	Ω	°C	Ω
-10	961	55	1213
-5	980	60	1232
0	1000	65	1252
5	1019	70	1271
10	1039	75	1290
15	1058	80	1309
20	1078	85	1328
25	1097	90	1347
30	1117	95	1366
35	1136	100	1385
40	1155	105	1404
45	1175	110	1423
50	1194	115	1442

Resistance values of the Pt1000 sensors

Operating control lamp off

Check the power supply

o.k.

The fuse of the controller could be blown. It can be replaced after the front cover has been removed (spare fuse is enclosed in the accessory bag).

10. Accessory

Sensors

Our product range includes high-precision platinum temperature sensors, flatscrew sensors, outdoor temperature sensors, indoor temperature sensors, cylindrical clip-on sensors and irradiation sensors, also as complete sensors with immersion sleeve.



Overvoltage protection device

In order to avoid overvoltage damage at collector sensors (e.g. caused by local lightning storms), we recommend installing the overvoltage protection RESOL SP1.



RESOL ServiceCenter Software

The RSC light software permits to read out measurement values of the controller for visualising and controlling the system status.

If you wish to carry out a heat quantity measurement, you need a flowmeter for measuring the flow rate in your system.

Distributed by:

RESOL - Elektronische Regelungen GmbH

Heiskampstraße 10
45527 Hattingen / Germany

Tel.: +49 (0) 23 24 / 96 48 - 0

Fax: +49 (0) 23 24 / 96 48 - 755

www.resol.de

info@resol.de

Important notice:

The text and drawings in this manual are correct to the best of our knowledge. As faults can never be excluded, please note: Your own calculations and plans, under consideration of the current standards and DIN-directions should only be basis for your projects. We do not offer a guarantee for the completeness of the drawings and texts of this manual - they only represent some examples. They can only be used at your own risk. No liability is assumed for incorrect, incomplete or false information and / or any resulting damages.

Please note:

The design and the specifications can be changed without notice. The illustrations may differ from the original product.

Reprinting / copying

This mounting- and operation manual including all parts is copyrighted. Another use outside the copyright requires the approval of RESOL - Elektronische Regelungen GmbH. This especially applies for copies, translations, micro films and the storage into electronic systems. Editor: RESOL - Elektronische Regelungen GmbH