

# RESOL DeltaSol® AL

**Mounting**

**Connection**

**Operation**

**Troubleshooting**

**Examples**



# DeltaSol® AL

en-US/CA

**Manual**

[www.resol.com](http://www.resol.com)



48006510

**Thank you for buying this RESOL product.  
Please read this manual carefully to get the best performance from this unit.  
Please keep this manual carefully.**

**Table of contents**

**Advice** ..... 2

**1. Overview** ..... 3

**2. Installation**..... 4

    2.1 Mounting..... 4

    2.2 Electrical connection ..... 5

    2.3 Data communication / Bus ..... 5

    2.4 Terminal allocation ..... 6

**3. Operation**..... 6

    3.1 Buttons for adjustment ..... 6

    3.2 System-Monitoring-Display ..... 7

    3.3 Slide switch ..... 8

    3.4 Flashing codes..... 8

**4. Control parameters and display channels** ..... 9

    4.1 Channel overview..... 9

    4.2 Display and adjustment values ..... 9

**5. Troubleshooting**..... 14

    5.1 Various ..... 15

**6. Accessories**..... 17

**Copyright** ..... 20

Subject to technical change. Errors excepted.

**General**

**Safety advice:**

Please read the following information carefully before installing and operating the controller. In this way damage to the solar system caused by wrong installation will be avoided. Please make sure that the mounting is adapted to the characteristics of the building, that the local regulations are respected and is conform with the technical rules.

Please pay attention to the following safety advice in order to avoid danger and damage to people and property.

**Instructions:**

Attention should be paid to

- Valid national and local standards and regulations
- Respective valid standards and directives

Equipment to be installed and used in accordance with the rules of the National Electrical Code (NEC) or with Canadian Electrical Code (CEC), Part I.

These instructions are exclusively addressed to authorized skilled personnel.

- Only qualified electricians should carry out installation and maintenance work.
- Initial installation should be carried out by qualified personnel

**Description of symbols**

<b>WARNING!</b>	<b>Warnings are indicated with a warning triangle!</b>
	→ They contain information on how to avoid the danger described.

Signal words describe the danger that may occur, when it is not avoided.

- **WARNING** means that injury, possibly life-threatening injury, can occur.
- **ATTENTION** means that damage to the appliance can occur.



**Note**

Notes are indicated with an information symbol.

→ Arrows indicate instruction steps that should be carried out.

**Disposal**

- Dispose of the packaging in an environmentally sound manner.
- Dispose of old appliances in an environmentally sound manner. Upon request we will take back your old appliances bought from us and guarantee an environmentally sound disposal of the devices.

**Information about the product**

**Proper usage**

The solar controller is designed for use in standard solar thermal systems in compliance with the technical data specified in this manual.

Improper use excludes all liability claims.



**Note**

Strong electromagnetic fields can impair the function of the controller.

- Make sure the controller as well as the system are not exposed to strong electromagnetic fields.

## 1. Overview



- **System-Monitoring-Display**
- **Easy-to-understand visualization of the system parameters**
- **Up to 3 Pt1000 temperature sensors**
- **Energy metering**
- **Function control**
- **Solar operating hours counter**
- **Housing with brandnew design**
- **Intuitive operating concept**
- **RESOL VBus®**
- **Energy-efficient through low standby power consumption**

### Included with the DeltaSol® AL

- 1 x DeltaSol® AL
- 1 x accessory bag
  - 3 x screw and wall plug
  - 5 x strain relief and screw

### Additionally included in the full kit:

- 1 x FKP6 sensor
- 1 x FRP6 sensor

### Technical data:

**Housing:** plastic, PC-ABS and PMMA

**Protection type:** IP 20/EN 60529

**Protection class:** II

**Ambient temp.:** 0 ... 40 °C  
[32 ... 104 °F]

**Dimensions:** 144 x 208 x 43 mm

**Installation:** wall mounting

**Display:** System-Monitor for visualization, 16-segment display, 7-segment display, 8 symbols for system states, background illumination and operating control lamp

**Operation:** 3 push buttons at the front of the housing and 1 slide switch

**Functions:** Differential temperature controller for standard solar thermal systems. Function control, operating hours counter for the solar pump, tube collector function and energy metering.

**Inputs:** for 3 Pt1000 temperature sensors

**Outputs:** 1 electromechanical relay with change-over contact

**Bus:** RESOL VBus®

**Power supply:** 12 VDC

**Power consumption:**  
standby: < 0.5 W  
maximum: < 0.7 W

**Total switching capacity:**

4 (1) A 12 VDC

**Mode of operation:** Type 1.B

**Switching capacity:**  
electromechanical relay:  
4 (1) A 12 VDC

## 2. Installation

### 2.1 Mounting

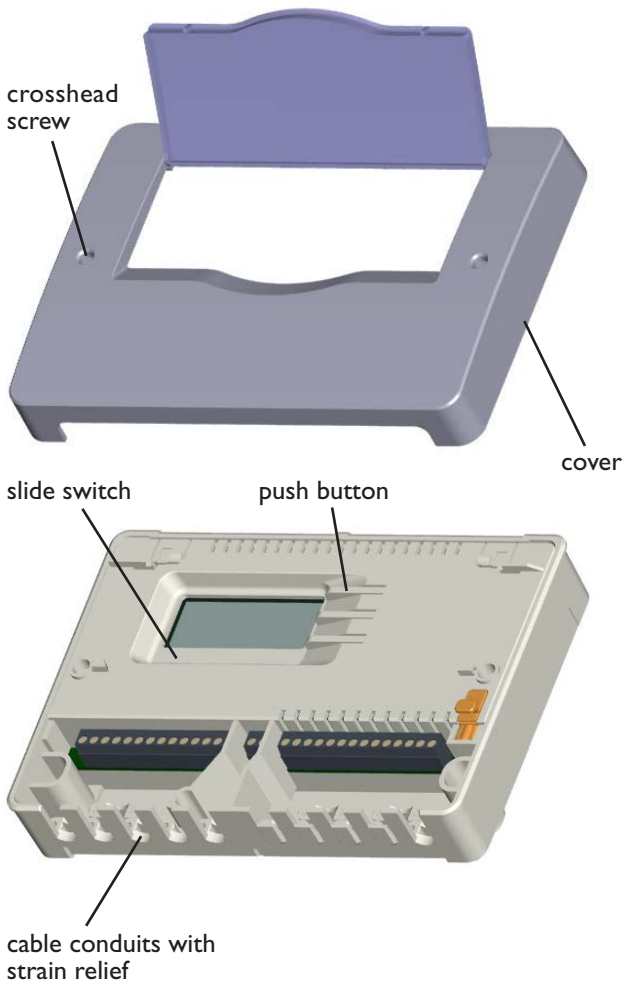

<b>WARNING!</b>	<b>Electric shock!</b>
	→ <b>Always disconnect the controller from power supply before opening the housing!</b>

The unit must only be located in dry interior rooms. It is not suitable for installation in hazardous locations and should be protected against electromagnetic fields. The controller must additionally be supplied from a double pole switch with contact gap of at least 3 mm. Please pay attention to separate routing of sensor cables and power supply cables.

- Unscrew the crosshead screw from the cover and remove the cover
- Mark the upper fastening point on the wall
- Drill and fasten the enclosed wall plug and screw leaving the head protruding
- Hang the housing from the upper fastening point and mark the lower fastening points (centres 180 mm)
- Drill and insert the lower wall plug
- Fasten the housing to the wall with the lower fastening screw and tighten

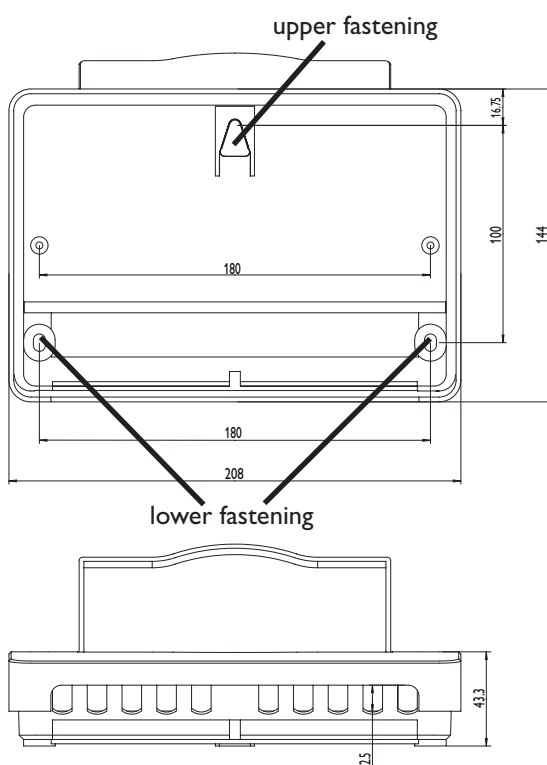

### System scheme DeltaSol® AL

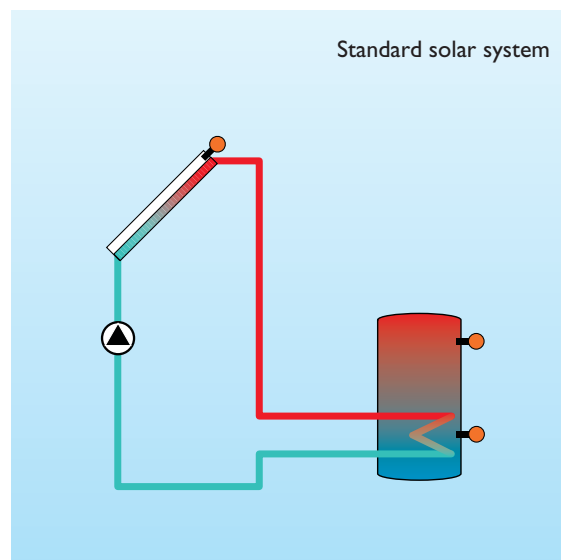

## 2.2 Electrical connection

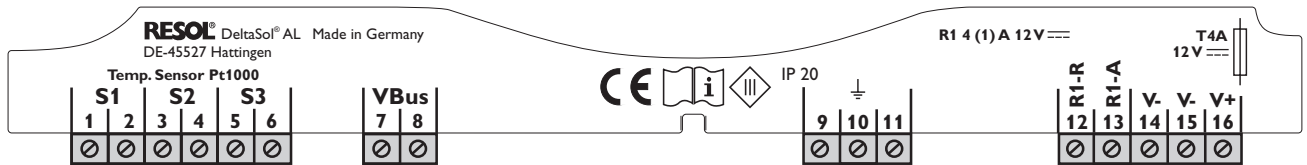

<b>ATTENTION!</b>	<p><b>ESD damage!</b> Electrostatic discharge can cause damage of electronic components!</p> <p>→ <b>Take care to discharge properly before touching the inside of the device!</b></p>

Connecting the device to the power supply must always be the last step of the installation!

The controller is supplied with power via a power supply line. The power supply of the device must be 12VDC.

The controller is equipped with a change-over relay to which a **load** such as a pump, a valve, etc. can be connected:

- 10 = ground terminal  $\perp$
- 11 = ground terminal  $\perp$
- 12 = conductor R1-R (normally closed contact)
- 13 = conductor R1-A (normally open contact)
- 14 = V- terminal

Depending on the product version, power supply cable and sensor cables are already connected to the device. If that is not the case, please proceed as follows:

Connect the **temperature sensors** (S1 to S3) to the corresponding terminals with either polarity:

- 1/2 = Sensor 1 (e. g. sensor collector)
- 3/4 = Sensor 2 (e. g. sensor tank)
- 5/6 = Sensor 3 (e. g. sensor tank top)

Connect the **RESOL VBus®** to the terminals marked "VBus" with either polarity:

- 7 = VBus terminal
- 8 = VBus terminal

Connect the **power supply cable** to the following terminals:

- 15 = V- terminal
- 16 = V+ terminal
- 9 = ground terminal  $\perp$

Attach flexible cables to the housing with the enclosed strain relief and the corresponding screws.

## 2.3 Data communication / Bus

The controller is equipped with the RESOL **VBus®** for data transfer with and energy supply to external modules. Carry out the connection at the two terminals marked "VBus" (any polarity). One or more RESOL VBus® modules can be connected via this data bus, such as:

- RESOL GA3 Large Display from version 1.21
- RESOL SD3 Smart Display from version 1.21
- RESOL DL2 Datalogger
- RESOL VBus® / USB interface adapter

## 2.4 Terminal allocation

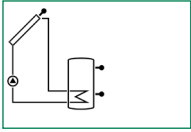

**Standard solar system** with one tank, one pump and three sensors. Sensors S1 / S2 are also used for energy metering.

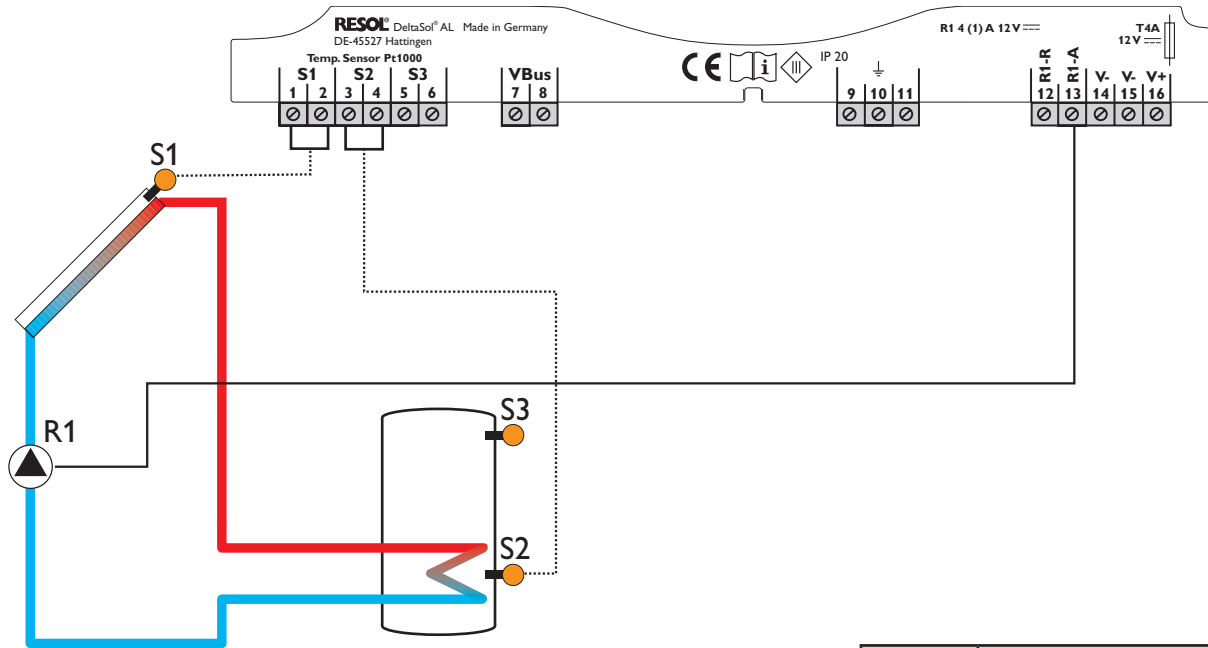

Symbol	Description
S1	collector sensor
S2	tank sensor base
S3	tank sensor top (optional)
R1-A	solar pump

## 3. Operation

### 3.1 Buttons for adjustment

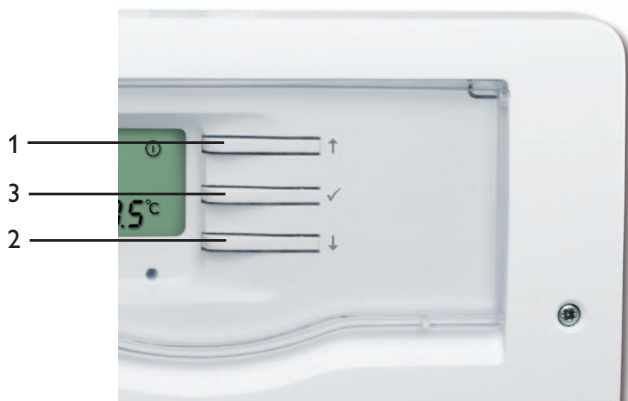

The controller is operated via the three push buttons next to the display. Button 1 is used for scrolling backwards through the display menu or to increase the adjustment values. Button 2 is similarly used for scrolling forward and reducing values.

In order to access the adjustment mode, scroll down in the display menu and press button 2 for approx. three seconds after you have reached the last display item. If an adjustment value is shown on the display, the **SET** icon is displayed. Now, you can access the adjustment mode by pushing button 3.

- ➔ Select the requested channel using buttons 1 and 2.
- ➔ Briefly press button 3, **SET** will flash (**SET** mode)
- ➔ Adjust the value by pressing buttons 1 and 2
- ➔ Briefly press button 3, so that **SET** permanently appears; the adjusted value will be saved.

### 3.2 System-Monitoring-Display

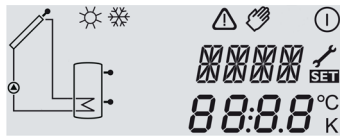

System-Monitoring-Display

The system monitoring display consists of three blocks: **channel display**, **tool bar** and **System-Screen**.

#### 3.2.1 Channel display

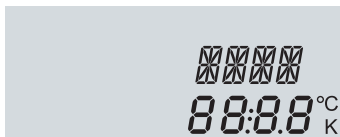

Channel display

The **channel display** consists of two lines. The upper line is an alpha-numeric 16-segment display (text display) for displaying channel names and menu items. In the lower 7-segment display, channel values and the adjustment parameters are displayed.

Temperatures and temperature differences in °C and K are displayed with the unit. If the indication is set to °F and °Ra, the units are not displayed.

#### 3.2.2 Tool bar



Tool bar

The additional symbols in the **tool bar** indicate the current system state.

Status	normal	blinkend
relay 1 active	ⓘ	
maximum tank limitation active / maximum tank temperature exceeded	☀	
collector cooling function active recooling function active		☀
antifreeze function activated	❄	
collector minimum limitation active antifreeze function active		❄
collector emergency shutdown active or tank emergency shutdown active		⚠
sensor fault S1	🔧	⚠
sensor fault S2	🔧 ☀	
manual mode active	👤	⚠
an adjustment channel is being changed - set mode		SET

### 3.2.3 System-Screen



System-Screen

The system screen shows the system. The screen consists of several system component symbols, which are – depending on the current status of the system – either flashing, permanently shown or “hidden”.

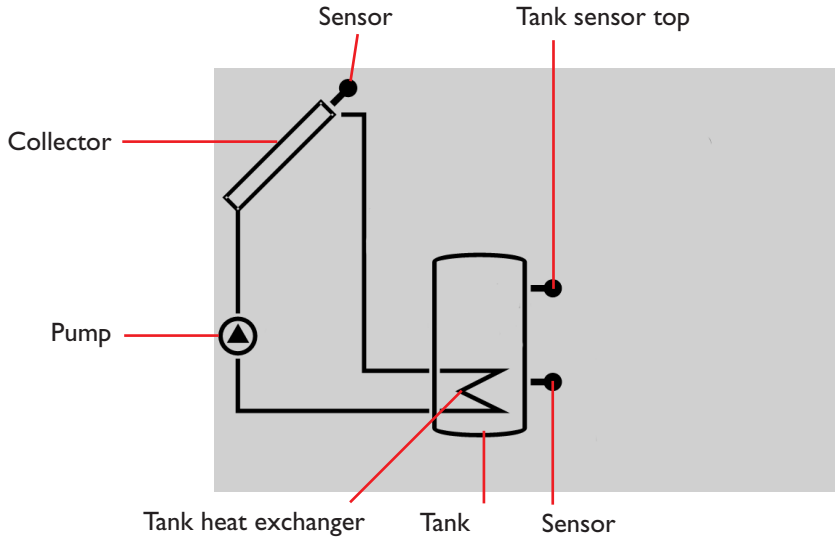

**Collector**  
with collector sensor



**Temperature sensor**



**Tank**  
with heat exchanger



**Pump**

### 3.3 Slide switch

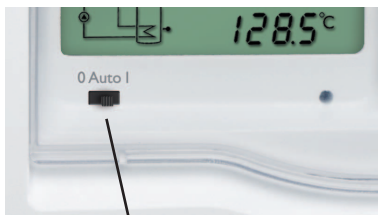

Slide switch

The relay can be manually switched on (ON), switched off (OFF) or put into automatic mode (AUTO). Normally, the switch should be left in the AUTO position.

- Manually ON = 0 (left)
- Manually OFF = 1 (right)
- Automatic = AUTO (center)

### 3.4 Flashing codes

#### 3.4.1 System-Screen flashing codes

- Pumps are flashing during initialization phase
- Sensor symbols are flashing while the corresponding sensor display channel is selected.
- Sensors are flashing quickly in the case of a sensor fault.

#### 3.4.2 LED flashing codes

- green: everything OK
- red/green flashing: initialization phase
- manual operation
- red flashing: Sensor defective (sensor symbol is flashing quickly)

## 4. Control parameters and display channels

### 4.1 Channel overview



**Note:**

Only if the temperature sensor is connected, will S3 be displayed!

Channel		Designation	Page
COL	D	temperature collector	10
TST	D	temperature tank	10
S3	D	temperature sensor 3	10
h P	D	operating hours relay	11
kWh	D	heat quantity kWh	11
MWh	D	heat quantity MWh	11
DT O	C	switch-on temperature difference	11
DT F	C	switch-off temperature difference	11
S MX	C	maximum temperature tank	12
EM	C	emergency temperature collector	12

D = Display

C = Control parameter

C\* = Corresponding channel is available when the corresponding option is enabled.

Channel		Designation	Page
OCX	C	option collector cooling collector	12
CMX	C*	maximum temperature collector	12
OCN	C	option minimum limitation collector	13
CMN	C*	minimum temperature collector	13
OCF	C	option antifreeze collector	13
CFR	C*	antifreeze temperature collector	13
OREC	C	option recooling	13
OTC	C	option tube collector	13
FMAX	C	maximum flow rate	14
MEDT	C	antifreeze type	14
MED%	C	antifreeze concentration	14
UNIT	C	unit	14
LANG	C	language	14
DSAL 1.00	C	version number	

### 4.2 Display and adjustment values

#### Display of collector temperature

**COL:**

collector temperature

display range:

-40...+260 °C

-40...+500 [°F]



Shows the current collector temperature.

- COL : collector temperature

#### Display of tank temperature

**TST:**

tank temperature

display range:

-40...+260 °C

-40...+500 [°F]



Shows the current tank temperature.

- TST : tank temperature

#### Display sensor 3

**S3:**

sensor temperature

display range:

-40...+260 °C

-40...+500 [°F]

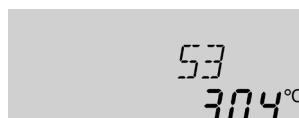

Shows the current temperature of the additional sensor (without control function).

- S3 : temperature sensor 3



**Note:**

Only if the temperature sensor is connected, will S3 be displayed!

## Operating hours counter

**h P:**  
operating hours counter  
display channel

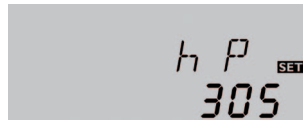

The operating hours counter accumulates the solar operating hours (**h P**) of the relay. Full hours are displayed.

The accumulated operating hours can be set back to zero. As soon as one operating hours channel is selected, the **SET** symbol is displayed.

→ In order to access the RESET-mode of the counter, press the SET (3) button for approx. two seconds.

The display symbol **SET** will flash and the operating hours will be set to zero.

→ Confirm the reset with the SET button in order to finish the reset.

In order to interrupt the RESET-process, do not press a button for about five seconds. The display returns to the display mode.

**kWh/MWh:**  
heat quantity in kWh / MWh  
display channel



Information on flow rate, antifreeze (-/concentration) and the temperature difference between the reference sensors S1 (flow) and S2 (return) are used for determining the heat quantity delivered. It is shown in kWh in the channel **kWh** and in MWh in the channel **MWh**. The overall heat quantity results from the sum of both values.

The accumulated heat quantity can be set back to zero. As soon as one of the display channels of the heat quantity is selected, the **SET** symbol flashes.

→ In order to access the RESET-mode of the counter, press the SET (3) button for approx. two seconds.

The display symbol **SET** will flash and the heat quantity will be set to zero.

→ Confirm the reset with the SET button in order to finish the reset.

In order to interrupt the RESET-process, do not press a button for about five seconds. The display returns to the display mode.



### Note:

The adjustment values should only be altered by qualified personnel. Otherwise, the system may not function faultlessly!

In order to access the adjustment mode, scroll down in the display menu and press button 1 for approx. three seconds after you have reached the last display item. If an adjustment value is shown on the display, the **SET** icon is displayed. Now, you can access the adjustment mode by pushing button 3.

**ΔT-regulation****DT O:**

switch-on temperature difference

adjustment range:

1.0 ... 20.0 K

2.0 ... 40.0 [°Ra]

factory setting:

6.0 K; 8.0 [°Ra]



If the switch-on difference (**DT O**) is reached, the pump is activated. If the temperature difference falls below the adjusted switch-off temperature difference (**DT F**) the controller switches off.

**DT F:**

switch-off temperature difference

adjustment range:

0.5 ... 19.5 K

1.0 ... 39.0 [°Ra]

factory setting:

4.0 K; 8.0 [°Ra]

**Note:**

The switch-on temperature difference must be at least 0.5 K (1 °Ra) higher than the switch-off temperature difference.

**Maximum tank temperature****S MX:**

maximum tank temperature

adjustment range:

4 ... 95 °C

40 ... 200 [°F]

factory setting:

60 °C; 140 [°F]

hysteresis: 2 K (4 °Ra)



Once the adjusted maximum temperature is exceeded, the solar pump is switched off and further loading of the tank is prevented to reduce scald risk or system damage. The ☀ symbol is shown on the display.

**Note:**

The controller is also equipped with a nonadjustable emergency switch-off if the tank reaches 95 °C (200 °F).

**Collector temperature limitation for emergency shutdown of the collector****EM:**

collector temperature limitation

adjustment range:

110 ... 200 °C

230 ... 400 [°F]

factory setting:

140 °C; 280 [°F]

hysteresis: 10 K (20 °Ra)

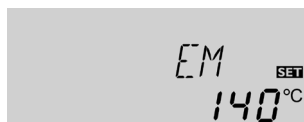

If the adjusted collector emergency shutdown temperature (**EM**) is exceeded, the controller switches off the solar pump in order to protect the system against overheating. The factory setting is 140 °C (280 °F) but it can be changed within the adjustment range of 110...200 °C (230 ... 400 °F). Δ (flashing) is shown if **EM** is exceeded.

**System cooling****OCX:**

option system cooling

adjustment range: OFF / ON

factory setting: OFF



When the adjusted maximum tank temperature is reached, the system stagnates. As soon as the collector temperature reaches the adjusted maximum collector temperature (**CMX**) the solar pump is activated until the collector temperature is 5 K (10 °Ra) lower than the maximum temperature. The tank temperature may increase, but only up to 95 °C (200 °F) (emergency shutdown of the tank).

**CMX:**

collector maximum temperature

adjustment range:

100 ... 190 °C

210 ... 380 [°F]

factory setting:

120 °C; 250 [°F]

hysteresis: 5 K (10 °Ra)



**If the OREC option is additionally activated:**

If the tank temperature is higher than the maximum tank temperature (**S MX**) and if the collector temperature is at least 5 K (10 °Ra) below the tank temperature, the solar system remains activated until the tank is cooled down below the adjusted maximum temperature (**S MX**) via the collector and the pipework.

If the system cooling function is activated, ☀ (flashing) is shown. Due to the cooling function, the system will have a longer operation time on hot summer days and guarantees thermal relief of the collector field and the heat transfer fluid.

**Option collector minimum limitation**

**OCN:**

collector minimum limitation  
adjustment range: OFF / ON  
factory setting: OFF

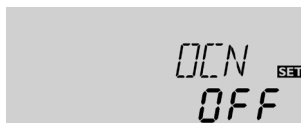

The collector minimum limitation option prevents the solar pump from being switched on too often at low collector temperatures. When this option is activated, the collector minimum temperature can be adjusted.

**CMN:**

collector minimum temperature  
adjustment range:  
10 ... 90 °C  
50 ... 200 [°F]  
factory setting:  
10 °C; 50 [°F]



The collector minimum temperature is the temperature which must be exceeded for the solar pump (R1) to switch on. If the temperature falls below the minimum temperature, ☀ (flashing) is shown.

**Antifreeze option**

**OCF:**

antifreeze function  
adjustment range: OFF / ON  
factory setting: OFF

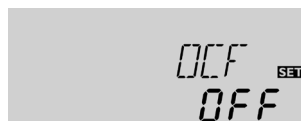

The antifreeze function activates the loading circuit between the collector and the tank when the temperature falls below the adjusted antifreeze temperature at the collector sensor. This will protect the fluid against freezing or coagulating. When this option is activated, the antifreeze temperature can be adjusted.

**CFR:**

antifreeze temperature  
adjustment range:  
-10 ... 10 °C  
10 ... 50 [°F]  
factory setting:  
4.0 °C; 40 [°F]



If the adjusted antifreeze temperature is exceeded by 1 °C (2 °Ra), the loading circuit will be deactivated.



**Note:**

Since this function uses the limited heat quantity of the tank, the antifreeze function should be used in regions with few days of temperatures around the freezing point.

**Option recooling**

**OREC:**

option recooling  
adjustment range: OFF / ON  
factory setting: OFF



If the adjusted maximum tank temperature (**S MX**) is reached, the controller keeps the solar pump running in order to prevent the collector from being overheated. The tank temperature may increase, but only up to 95 °C (200 °F) (emergency shutdown of the tank).

If the tank temperature is higher than the maximum tank temperature (**S MX**) and if the collector temperature is at least 5 K (10 °Ra) below the tank temperature, the solar system remains activated until the tank is cooled down below the adjusted maximum tank temperature (**S MX**) via the collector and the pipework.

**Evacuated tube collector function****OTC:**

tube collector function  
adjustment range: OFF / ON  
factory setting: OFF



If the controller detects an increase in collector temperature by 2 K (4 °Ra) compared to the previously stored collector temperature, the solar pump will be switched-on for about 30 seconds in order to detect the fluid temperature. The current collector temperature will be saved as a new reference value. If the measured temperature (new reference value) is exceeded by 2 K (4 °Ra), the solar pump will run for 30 seconds. If the switch-on difference between the collector and the tank is exceeded during the runtime of the solar pump, the controller will automatically switch to solar loading.

If the collector temperature decreases by 2 K (4 °Ra) during a loading break, the switch-on value for the evacuated tube collector function will be recalculated.

**Energy metering****FMAX:**

flow rate in l/min  
adjustment range: 0 ... 20  
in 0.1 steps  
factory setting: 6.0



Energy metering is possible if a flow gauge is used.

→ Read the flow rate (l/min) from the flow gauge and adjust it in the **FMAX** channel.

→ Adjust the antifreeze type and concentration of the heat transfer fluid in the channels **MEDT** and **MED%**.

**MEDT:**

antifreeze type  
adjustment range: 0 ... 3  
factory setting: 1

**Antifreeze type:**

- 0 : water
- 1 : propylene glycol
- 2 : ethylene glycol
- 3 : Tyfocor® LS / G-LS

**MED%:**

concentration of antifreeze  
in (Vol-) %  
MED% is "hidden" when MEDT  
0 or 3 is used  
adjustment range: 20 ... 70  
factory setting: 45

**Temperature units****UNIT:**

Temperature unit  
adjustment range: °C, °F  
factory setting: °C



In this adjustment channel the temperature unit can be chosen. The unit can be switched between °C and °F during operation.

Temperatures and temperature differences in °C and K are displayed with the unit. If the indication is set to °F and °Ra, the units are not displayed.

**Language****LANG:**

language selection  
adjustment range: dE, En, It, Fr  
factory setting: En



In this adjustment channel the menu language can be chosen.

- dE : German
- En : English
- It : Italian
- Fr : French

### 5. Troubleshooting

If a malfunction occurs, an error code will be indicated on the display by means of symbols (see chap. 3.2.2).



Symbols    Operating control lamp

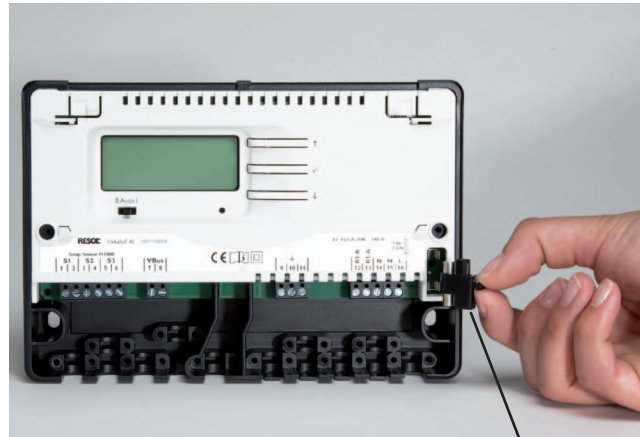

Fuse holder

Operating control lamp flashes red. The symbol and the are shown.

Sensor fault. An error code instead of a temperature is shown on the sensor display channel.

888.8

- 88.8

Cable is broken. Check the cable.

Short-circuit. Check the cable.

Disconnected Pt1000 temperature sensors can be checked with an ohmmeter. In the following table, the resistance values corresponding to different temperatures are listed.

°C	°F	Ω	°C	°F	Ω
-10	14	961	55	131	1213
-5	23	980	60	140	1232
0	32	1000	65	149	1252
5	41	1019	70	158	1271
10	50	1039	75	167	1290
15	59	1058	80	176	1309
20	68	1078	85	185	1328
25	77	1097	90	194	1347
30	86	1117	95	203	1366
35	95	1136	100	212	1385
40	104	1155	105	221	1404
45	113	1175	110	230	1423
50	122	1194	115	239	1442

Resistance values of the Pt1000 temperature sensors

The controller is protected by a fuse. The fuse holder (which also holds the spare fuse) becomes accessible when the cover is removed. To replace the fuse, pull the fuse holder from the base.

Operating control lamp off.

Check the power supply. Is it disconnected?

no

yes

The fuse of the controller could be blown. It can be replaced after the front cover has been removed (spare fuse is enclosed in the fuse holder).

Check the supply line and reconnect it.

5.1 Various

Pump is overheated, but no heat transfer from the collector to the tank, flow and return have the same temperature; perhaps also bubbles in the pipes

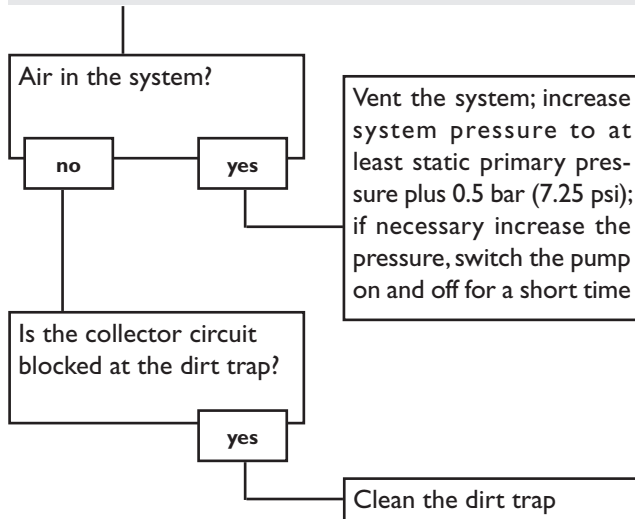

Pump starts for a short moment, switches on/off again, etc.

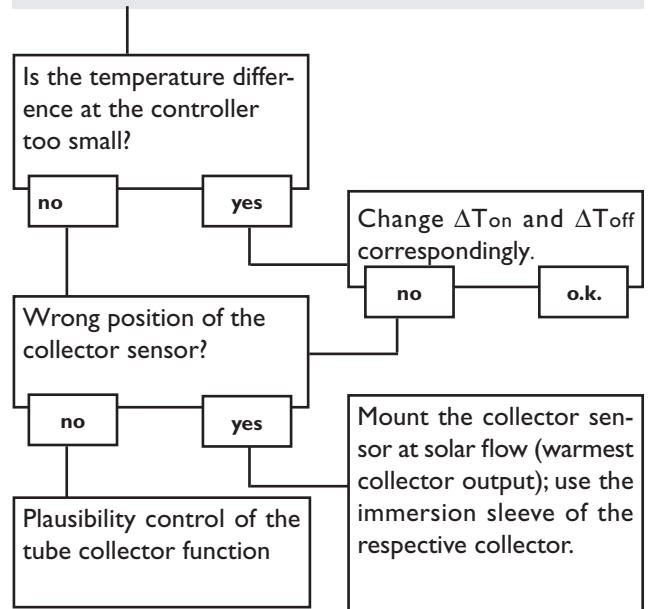

Pump starts up very late.

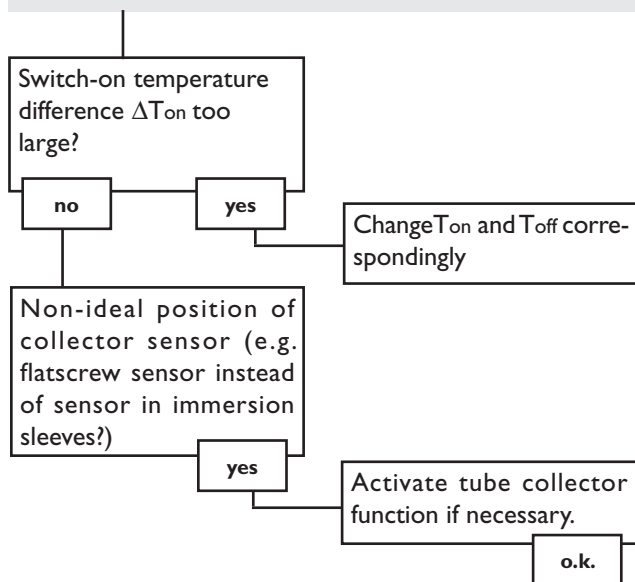

The temperature difference between the tank and the collector increases enormously during operation; the collector circuit cannot divert the heat.

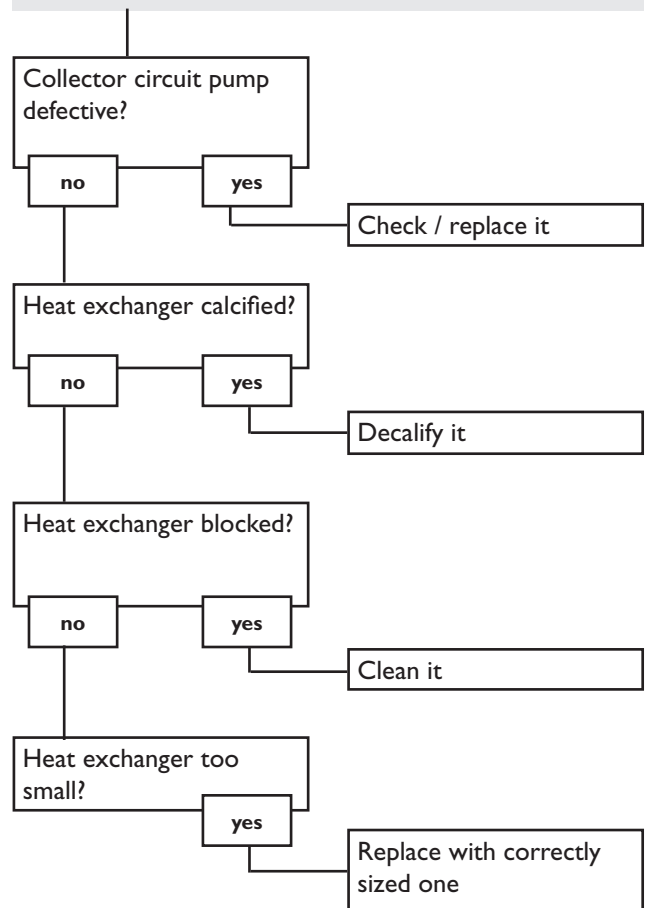

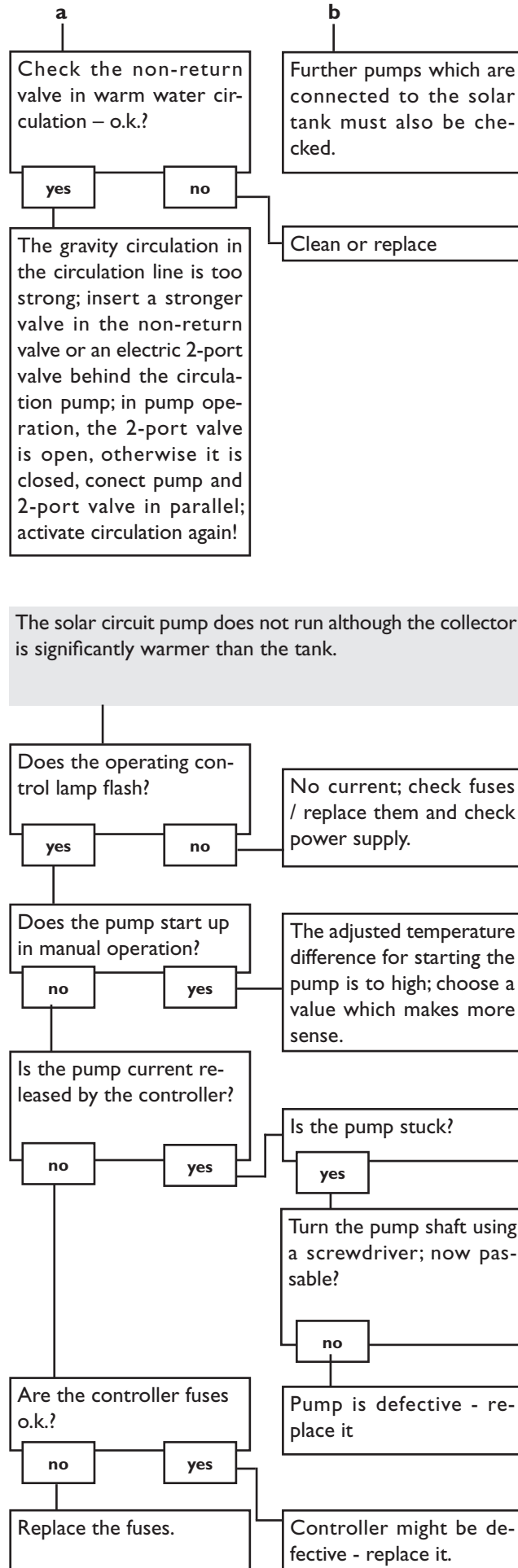
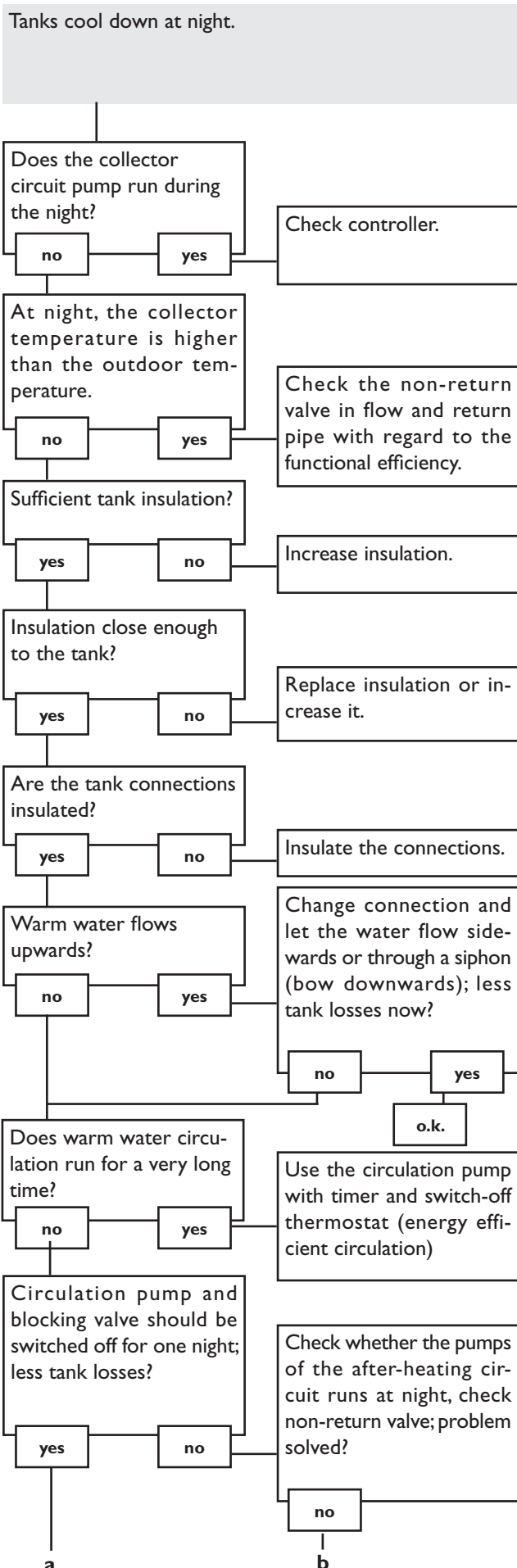

## 6. Accessories

### Sensors

Our product range includes high-precision platinum temperature sensors, flatscrew sensors, outdoor temperature sensors, indoor temperature sensors, cylindrical clip-on sensors, also as complete sensors with sensor wells.

For more information, see our catalogue and price list.



### Overvoltage protection device

In order to avoid overvoltage damage at collector sensors (e.g. caused by local lightning storms), we recommend the overvoltage protection RESOL SP10.

**RESOL SP10**

Article no.: **180 110 70**



### Smart Display SD3

The RESOL Smart Display is designed for simple connection to RESOL controllers with RESOLVBus®. It is used for visualizing data issued by the controller: collector temperature, storage temperature and energy yield of the solar thermal system. The use of high-efficient LEDs and filter glass assures a high optical brilliance and good readability even in poor visibility conditions and from a larger distance. An additional power supply is not required.

**RESOL SD3**

Article no.: **180 004 93**



### Large Display GA3

The RESOL Large Display GA3 is designed for simple connection to RESOL controllers via the RESOLVBus®. It is used for visualizing the data issued by the controller: collector and tank temperature as well as heat quantity produced in the solar system.

The use of high-efficient LEDs and antireflective filter glass assures a high optical brilliance and good readability - even in poor lighting conditions and at a larger distance.

**RESOL GA3**

Article no.: **180 006 53**



### DL2 Datalogger

This additional module enables the acquisition and storage of large amounts of data (such as measuring and balance values of the solar system) over a long period of time. The DL2 can be configured and read-out with a standard internet browser via its integrated web interface. For transmission of the data stored in the internal memory of the DL2 to a PC, an SD card can be used.

The DL2 is appropriate for all controllers with RESOLVBus®. It can be connected directly to a PC or router for remote access and thus enables comfortable system monitoring for yield monitoring or for diagnostics of faults.

**RESOL DL2**

Article no.: **180 007 10**



### VBus® / USB interface adapter

The new VBus® / USB interface adapter is the interface between the controller and a personal computer. With its standard mini-USB port it enables a fast transmission of system data for processing, visualizing and archiving as well as the parameterization of the controller via the VBus®. A full version of the RESOL ServiceCenter software is included.

**RESOL VBus® / USB interface adapter**

Article no.: **180 008 50**



**Notes**

**Notes**

**Distributed by:****RESOL - Elektronische Regelungen GmbH**

Heiskampstraße 10  
45527 Hattingen / Germany

Tel.: +49 (0) 23 24 / 96 48 - 0

Fax: +49 (0) 23 24 / 96 48 - 755

[www.resol.com](http://www.resol.com)

[info@resol.com](mailto:info@resol.com)

**Important notice:**

The texts and drawings in this manual are correct to the best of our knowledge. As faults can never be excluded, please note: Your own calculations and plans, under consideration of the current standards should only be basis for your projects. We do not offer a guarantee for the completeness of the drawings and texts of this manual - they only represent some examples. They can only be used at your own risk. No liability is assumed for incorrect, incomplete or false information and / or any resulting damages.

**Please note:**

The design and the specifications can be changed without prior notice. The illustrations may differ from the original product.

**Reprinting / copying**

This mounting- and operation manual including all parts is copyrighted. Another use outside the copyright requires the approval of RESOL - Elektronische Regelungen GmbH. This especially applies for copies, translations, micro-films and the storage into electronic systems.

Editor: RESOL - Elektronische Regelungen GmbH