

# FriWa controller

**Connection**

**Commissioning**

**Operation and function**



# FriWa



48002130

Thank you for buying this RESOL product.  
Please read this manual carefully to get the best performance from this unit.

GB  
Manual

[www.resol.de](http://www.resol.de)

**Safety advice**

Please pay attention to the following safety advice in order to avoid danger and damage to people and property.

**Instructions**

Attention should be paid to

- valid local regulations
- the statutory provisions for prevention of industrial accidents,
- the statutory provisions for environmental protection,
- the Health and Safety at Work Act 1974
- Part P of the Building Regulations 2005
- BS7671 Requirements for electrical installations and relevant safety regulations of DIN, EN, DVGW, TRGI, TRF and VDE.

These instructions are exclusively addressed to authorised skilled personnel.

- Only qualified electricians should carry out electrical works.
- Initial installation must be effected by qualified personnel named by the manufacturer

**Table of contents**

<b>Safety advice</b> .....	<b>2</b>
<b>Technical data and overview of functions</b> .....	<b>3</b>
<b>1. Hydraulic system</b> .....	<b>4</b>
1.1 Description .....	4
<b>2. Operation, commissioning and options</b> .....	<b>4</b>
2.1 Operation .....	4
2.2 Commissioning .....	5
2.3 Circulation option (demand variant) .....	6
2.4 Circulation option (thermostatic variant) .....	7
2.5 Return connection option .....	8
2.6 Options: Error relay, Signal relay and Emergency operation .....	9
<b>2.7 Activating the emergency operation</b> .....	<b>9</b>
2.8 Balance values, heat quantity measurement .....	9
2.9 Manual operation .....	9
<b>3. Connection</b> .....	<b>10</b>
3.1 Overview of electrical connections .....	10
3.1.1 Relay outputs .....	11
3.1.2 Sensors .....	11
3.1.3 Daten communication / bus .....	12
3.1.4 Mains connections .....	12
3.1.5 Flashing codes .....	12
3.1.6 Menu structure .....	13
<b>4. Overview of functions and options</b> .....	<b>14</b>
<b>Imprint</b> .....	<b>16</b>

Subject to change. Errors excepted.

**Declaration of conformity**

We, RESOL Elektronische Regelungen GmbH, D-45527 Hattingen, declare under our sole responsibility that our product FriWa complies with the following standards:

EN 55 014-1

EN 60 730-1

According to the regulations of the above directives, the product is labelled with



89/336/EWG

73/ 23/EWG

Hattingen, 07.Juli 2006

RESOL Elektronische Regelungen GmbH,

ppa. Gerald Neuse

## Technical data and functional overview

- Installation and initial operation of the station are easy as the electrical and hydraulic components are already pre-assembled
- Protection against legionella
- Reduced heat losses
- Illuminated text display
- Optional circulation for hot water delivery without any delay
- VBus®



### Technical data

**Housing:** plastic, PC-ABS and PMMA

**Protection type:** IP 20 / DIN 40 050

**Ambient temp.:** 0...40 °C

**Dimensions:** 220 x 155 x 62 mm

**Mounting:** mouting into the FriWa casing

**Operation:** three push buttons at the front of the housing

**Bus:** RESOLVBus®

**Power supply:** 220 ... 240 V~

**Switching capacity:** 4 (1) A (220 ... 240) V~

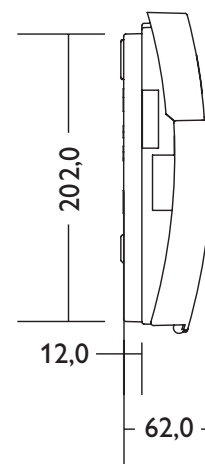
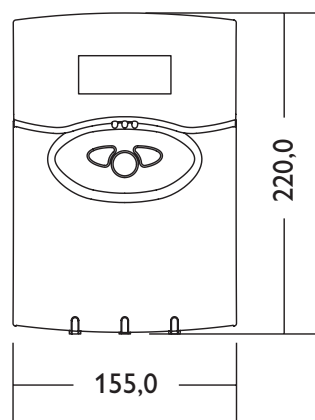

Attention: Electrostatic discharge can cause damage of electronic components



Warning: high-voltage components

# 1 Hydraulic system

## 1.1 Description

- Detects hot water delivery from 1,5 l/min up to 40 l/min
- Hot water delivery at set temperature
- Calculation of required pump speed with cold water, source, and hot water set temperature and the measured flow rate
- Quick reaction to changes of flow rate

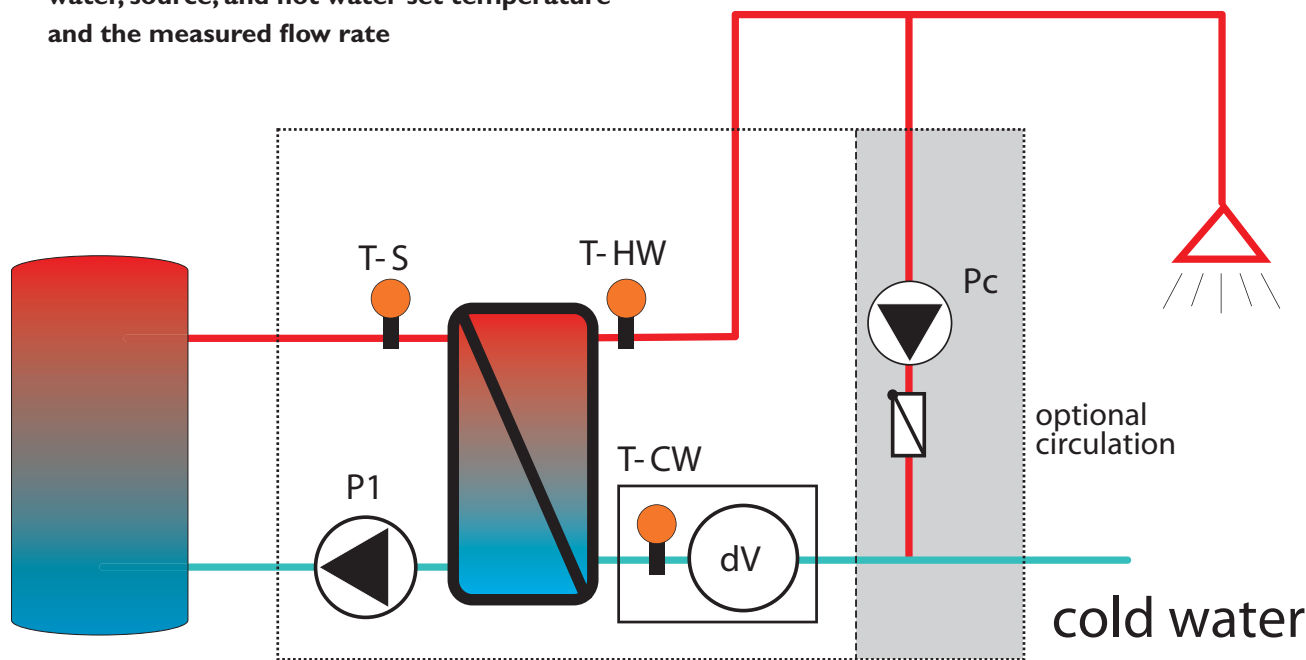

P1	loading pump	T-CW	sensor - cold water temperature
Pc	circulating pump (optional)	T-S	sensor - heat source temperature
T-HW	sensor - hot water temperature	dV	flow rate - measuring device

## 2. Operation, commissioning and options

### 2.1 Operation

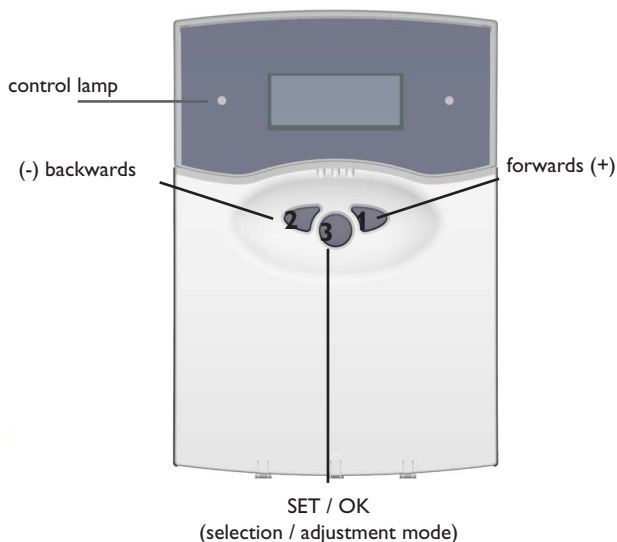

The controller is operated via the 3 push buttons below the display. The forward-button (1) is used for scrolling forward through the menu or to increase the adjustment values. The backward-button (2) is similarly used for scrolling backwards and reducing values.

Button 3 is used for adjusting the individual parameters. Press the button in order to access the sub-menu or the SET mode. Button 3 is also used for confirmation.

By selecting the menu line „back“ and pressing the SET/OK button, the display returns to the main menu. If no button is pressed within 60 seconds, the display changes back to the main menu.

**Note:** The choice of adjustment values and options depends on different functions and the user code. Some only appear in the display if they are available for the adjusted system parameters.

**User code:** Expert - Code 119

After the user code has been entered, the expert menu is accessible and the corresponding values can be changed.

## 2.2 Commissioning

MAIN MENU:
MEAS. VALUES
REPORTS
BALANCES
SETTINGS
OPTIONS
MANUAL OPERATION
USER CODE
EXPERT

### --> 1. Testing the sensors

MEAS. VALUES:		
Parameter	Range	Description
T-HW	-50,0 ... 250,0 °C	hot water temperature
T-CW	-50,0 ... 250,0 °C	cold water temperature
T-S	-50,0 ... 250,0 °C	heat source temperature
TAP	0 ... 9999 l/h	flow rate
TIME	Mo. 00:00 ...Su. 23:59, default is Su. 12:00	clock time
LOAD. PUMP	0 ... 99999 h, default is 0	speed of loading pump
RELAY 1-5	On / Auto / Off default is Auto	speed or status of relays 1-5
SEN. 1-9	-50,0 ... 250,0 °C	measured value - sensors 1-9

### --> 2. Adjusting the hot water set temperature

SETTINGS:		
Parameter	Range	Description
TIME	0:00-23:59 h	adjust the actual time
HOTWATER	45 ... 65 °C, default is 55 °C	set temperature - hot water; adaptation of blocking protection if necessary.
BP ON	0:00-23:59 h, default is 06:00 h	start blocking protection
BP OFF	0:00-23:59 h, default is 22:00 h	stop blocking protection
BP WAIT	0:30-06:00 h, default is 04:00 h	break time between starts pump

Test the functioning of hot water delivery by opening the tap. Vent the system if necessary.

### --> 3. Activating the options required

OPTIONEN			
Parameter	Range	Description	Page
CIRCULAT.	No/Dem./Therm.	circulation	6-7
RETURN DIV.	Off/On	return connection	8
ERROR REL.	No/R4/R5/R4+R5	error relay	9
SIGNAL REL.	No/R4/R5/R4+R5	signal relay	9
EXTERN OFF.	Off/On	external shutdown	9
EMERGENCY	Off/On	emergency operation	9

### --> 4. Checking the sensor position

- are reasonable values displayed?
- are sensors interchanged (return connection option)?

#### Note:

After the options have been activated, the measurement values and adjustment values are displayed (menu lines in grey).

MEAS. VALUES:
BACK
T-HW
T-CW
T-S
TST
T-R
T-C
TAP
TIME
LOAD. PUMP
CIRCULATION
RETURN VALVE
RELAY 1-5
SEN. 1-9

### 2.3 Circulation option (demand variant)

#### Control of circulating pump via demand (impulse)

A short impulse starts the circulating pump. The pump is operated for the adjusted period of time (Circ. run). After this period of time, a new circulation demand will be blocked for the adjusted period of time (Circ. wait). The active function will be shown on the display.

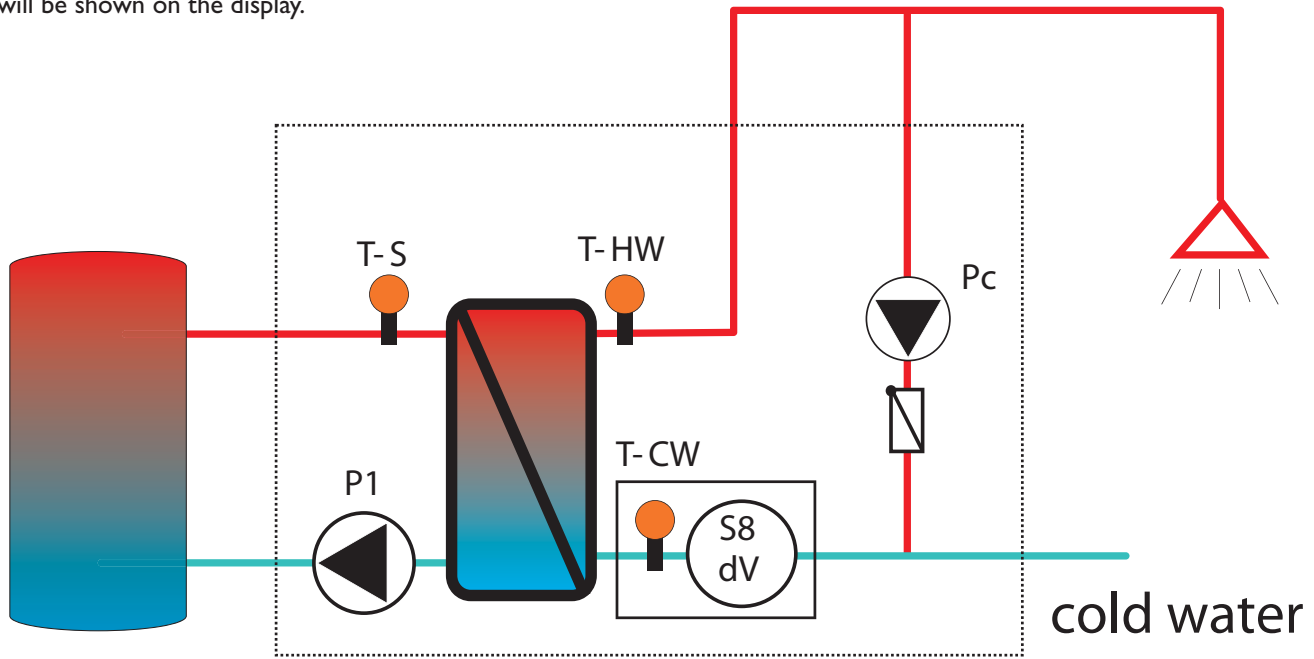

- P1 loading pump
- Pc circulating pump (optional)
- T-HW sensor - hot water temperature
- T-CW sensor - cold water temperature
- T-S sensor - heat source temperature
- dV flow rate measuring instrument

#### Activating the circulation (demand):

##### --> 1. Options

MAIN MENU: MEAS. VALUES REPORTS BALANCES SETTINGS OPTIONS MANUAL OPERATION USER CODE EXPERT	OPTIONS					
	<table border="1"> <thead> <tr> <th>Parameter</th> <th>Range</th> <th>Description</th> </tr> </thead> <tbody> <tr> <td>CIRCULAT.</td> <td>NO/DEM./THERM. default is NO</td> <td>demand circulating pump starts after the tap has been opened</td> </tr> </tbody> </table>	Parameter	Range	Description	CIRCULAT.	NO/DEM./THERM. default is NO
Parameter	Range	Description				
CIRCULAT.	NO/DEM./THERM. default is NO	demand circulating pump starts after the tap has been opened				

##### --> 2. Adjustment values

MAIN MENU: MEAS. VALUES REPORTS BALANCES SETTINGS OPTIONS MANUAL OPERATION USER CODE EXPERT	SETTINGS								
	<table border="1"> <thead> <tr> <th>Parameter</th> <th>Range</th> <th>Description</th> </tr> </thead> <tbody> <tr> <td>CIRC. RUN</td> <td>1 ... 10 Min., default is 2 Min.</td> <td>runtime of circulating pump</td> </tr> <tr> <td>CIRC. WAIT</td> <td>0 ... 20 Min., default is 10 Min.</td> <td>breaktime of circulating pump</td> </tr> </tbody> </table>	Parameter	Range	Description	CIRC. RUN	1 ... 10 Min., default is 2 Min.	runtime of circulating pump	CIRC. WAIT	0 ... 20 Min., default is 10 Min.
Parameter	Range	Description							
CIRC. RUN	1 ... 10 Min., default is 2 Min.	runtime of circulating pump							
CIRC. WAIT	0 ... 20 Min., default is 10 Min.	breaktime of circulating pump							

##### --> 3. Measured values

MAIN MENU: MEAS. VALUES REPORTS BALANCES SETTINGS OPTIONS MANUAL OPERATION USER CODE EXPERT	MEAS. VALUES					
	<table border="1"> <thead> <tr> <th>Parameter</th> <th>Range</th> <th>Description</th> </tr> </thead> <tbody> <tr> <td>CIRCULATION</td> <td>OFF ... OFF</td> <td>status of circulating pump</td> </tr> </tbody> </table>	Parameter	Range	Description	CIRCULATION	OFF ... OFF
Parameter	Range	Description				
CIRCULATION	OFF ... OFF	status of circulating pump				

##### --> 4. Checking the function

Open tap for hot water delivery.

## 2.4 Circulation option (thermostat variant)

### Control of circulating pump (thermostatic)

Within a given time frame (timer WT), the temperature of the hot water pipe is monitored using the T-C sensor. If this temperature falls below the adjusted minimum temperature (Circ. min), the circulating pump is activated. It is switched off when the temperature of the hot water in the pipe has increased by the heating hysteresis (Circ. hyst.).

The active function will be shown on the display.

Sensor T-C can either be combined with a sensor at S5, S6 or with sensor S7 (factory setting T-CW).

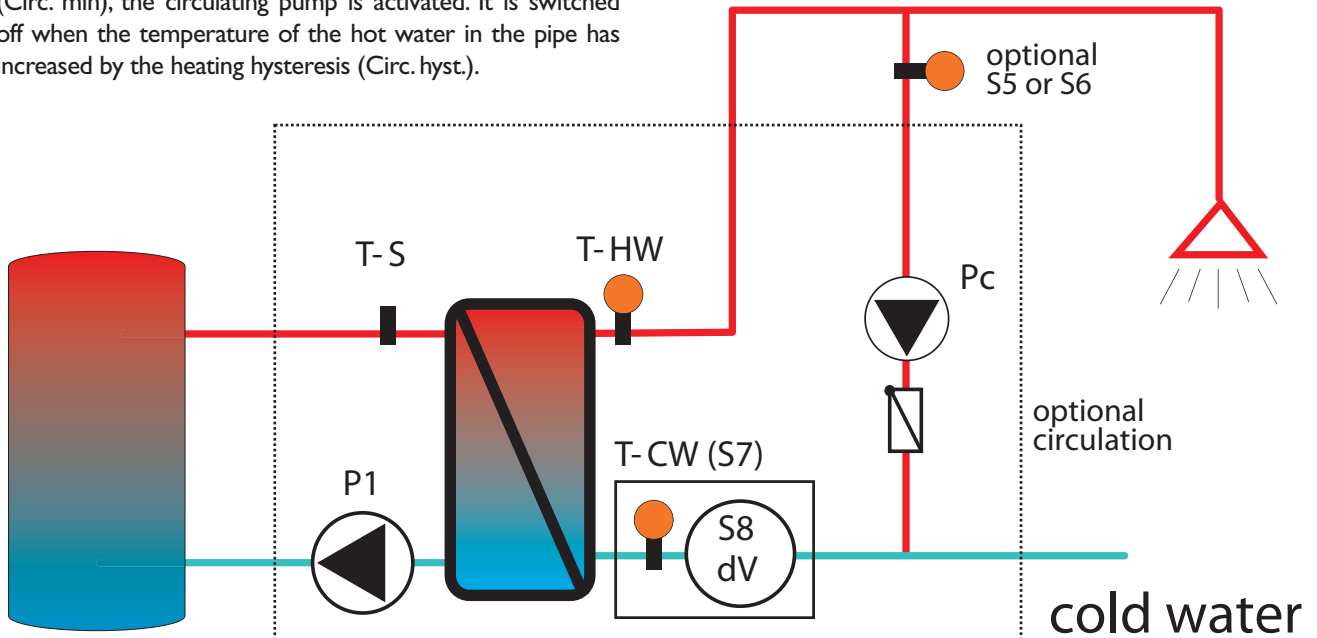

P1	loading pump	T-CW	sensor - cold water temperature
Pc	circulating pump (optional)	T-S	sensor - heat source temperature
T-HW	sensor - hot water temperature	dV	flow rate - measuring instrument

### --> 1. Options

OPTIONS		
Parameter	Range	Description
CIRCULAT.	NO/DEP./THERM. default is NO	thermostatic thermostatic control of circulating pump

### --> 2. Adjustment values

SETTINGS		
Parameter	Range	Description
CIRC. SENSOR	S5/S6/S7, default is S7	sensor selection - circulation return
CIRC.-HYST.	0,5..10,0 K, default is 5,0 K	heating hysteresis - circulation
CIRC.-MIN.	10..60° C, default is 40° C	minimum temperature - circulation
WEEK TIMER CIRC.	00:00..23:59, default is Mo-Su, On-Off 05:00-08:00, 11:00-14:00, 18:00-21:00	weekly timer - circulation adjust the desired operating time of the circulating pump

### --> 3. Measured values

MEAS. VALUES		
Parameter	Range	Description
T-C	-50 ... 250 °C	temperature - circulation return
CIRCULATION	OFF ... ON	status of circulating pump

### --> 4. Check function

MAIN MENU:
MEAS. VALUES
REPORTS
BALANCES
SETTINGS
OPTIONS
MANUAL OPERATION
USER CODE
EXPERT

## 2.5 Return connection option

### Return connection

During low demand or circulation, high return temperatures can be generated. These can be fed to the buffer store at a higher temperature level using the 3 port valve. This will avoid mixing with the lower cooler zone.

When the difference between return temperature (T-R) and store reference temperature (T-St) exceeds the adjusted switch-on difference (dT-Rd on), relay RC is energised. It

is deactivated when the loading circuit is not operated or when the difference falls below the adjusted switch-off difference (dT-Rd off).

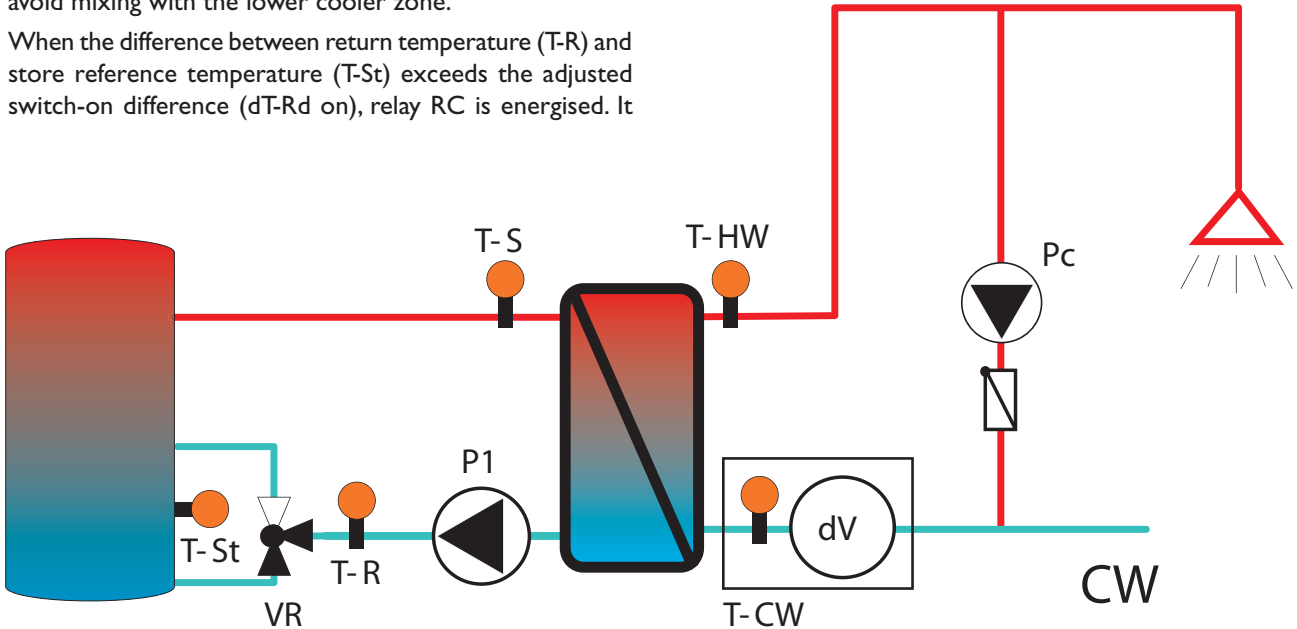

- P1 loading pump
- Pc circulating pump (optional)
- T-HW sensor - hot water temperature
- T-CW sensor - cold water temperature
- T-S sensor - heat source temperature
- dV flow rate - measuring instrument

MAIN MENU:

MERS. VALUES

REPORTS

BALANCES

SETTINGS

OPTIONS

MANUAL OPERATION

USER CODE

EXPERT

**--> 1. Options**

OPTIONS		
Parameter	Range	Description
RETURN DIV.	OFF/ON, default is OFF	On

**--> 2. Adjustment values**

SETTINGS		
Parameter	Range	Description
DT-RD ON	0,0 ... 25,0 K, default is 5,0 K	switch-on difference - return valve
DT-RD OFF	0,5 ... 10,0 K, default is 5,0 K	switch-off difference - return valve

**--> 3. Measured values**

MERS. VALUES		
Parameter	Range	Description
T-ST	-50 ... 250 °C	store temperature
T-R	-50 ... 250 °C	return temperature
RETURN VALVE	OFF/ON	status of return connection valve (RC)

**--> 4. Check function**

## 2.6 Options: Error relay, message relay, emergency operation

### Options:

Parameter	Range	Description	
ERROR REL.	NEIN/R4/R5/R4+R5	Error relay	In the case of a sensor or controller fault, the error relay is switched off.
SIGNAL REL.	NEIN/R4/R5/R4+R5	Message relay	When the primary circuit is operated (domestic hot water), the relay is energised. The message relay can be selected (R4 and/or R5)
EXTERN OFF	OFF/ON	External shutdown	Control can be shut down using the input S9..
EMERGENCY	OFF/ON	Emergency operation	The pump can be operated with a set pump speed level in continuous operation.

## 2.7 Activating the emergency operation

MAIN MENU:
MEAS. VALUES
REPORTS
BALANCES
SETTINGS
OPTIONS
MANUAL OPERATION
USER CODE
EXPERT

### --> 1. Options

Parameter	Range	Description
EMERGENCY	OFF/ON, default is OFF	On

### --> 2. Einstellwerte

Parameter	Range	Description
EMERGENCY	12 ... 100 %, default is 100 %	pump speed during emergency operation

## 2.8 Balance values, heat quantity measurement

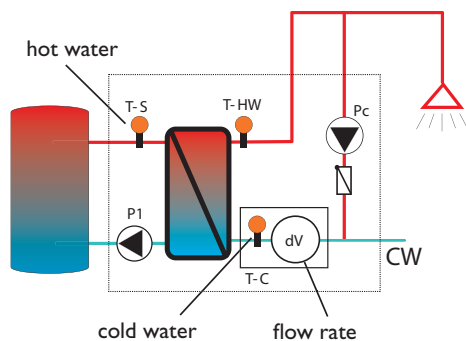

Parameter	Description
OPERATION	operating days of controller
VOLUME	water quantity delivered (cold water supply)
VOL. MAX	maximum flow rate
LOAD. P.	operating hours loading pump (P1)
CIRC. -P.	operating hours circulating pump (Pc)
T-S MIN	minimum source temperature (T-S)
T-S MAX	maximum source temperature (T-S)
T-CW MIN	minimum temperature of cold water (T-CW)
T-CW MAX	maximum temperature of cold water (T-CW)
HEAT QTY	energy exchanged - hot water circuit

Energy is measured using the measured flow rate, cold water and hot water temperature.

## 2.9 Manual mode

MAIN MENU:
MEAS. VALUES
REPORTS
BALANCES
SETTINGS
OPTIONS
MANUAL OPERATION
USER CODE
EXPERT

The individual relays can be switched-on, switched-off, or set into automatic mode.

Parameter	Range	Description
RELAY 1-5	OFF/AUTO/ON	Auto

### 3. Connection

#### 3.1 Overview of electrical connection

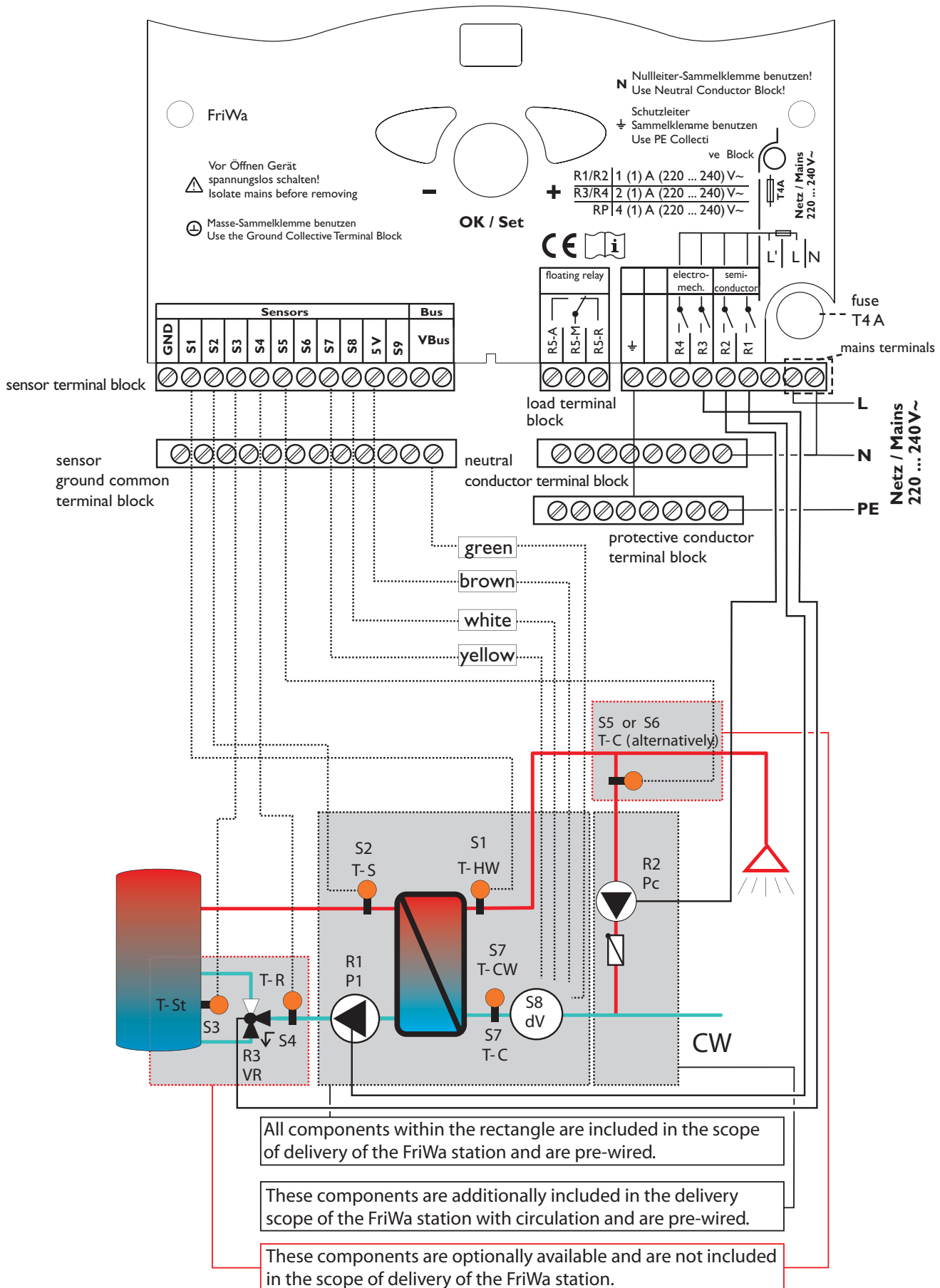

The DHW heat exchange module is already assembled and wired. Points 3.1.1 - 3.1.4 are for information only.

The mains connection (220 ... 240 V~) has to be carried out using the mains cable which is already connected to the terminals. Service and maintenance work have to be carried out by skilled personnel only, in accordance with the valid local regulations and directives (as VDE 0100, VDE 0185, VDE 0190 etc. in Germany).

Ground the FriWa properly at the mounting bracket!

### 3.1.1 Relay outputs

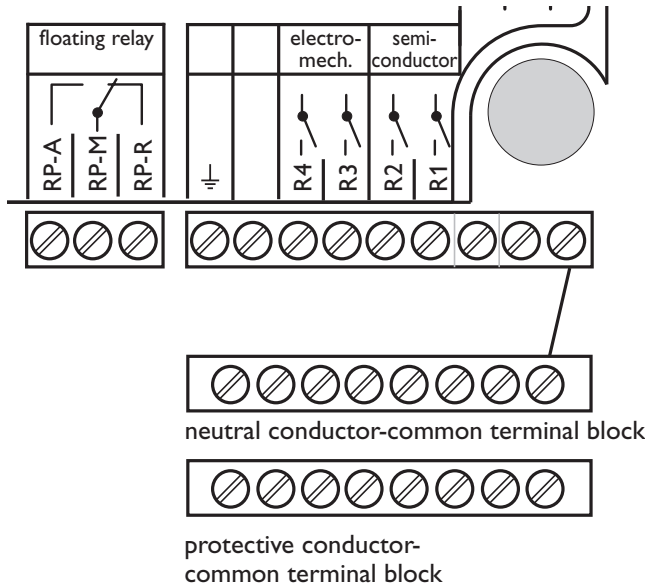

The controller is equipped with 5 relays in total to which loads (actuators) such as pumps, valves, and auxiliary relays can be connected:

- Relays R1 and R2 are semiconductor relays, also designed for pump speed control:  
 R1 ... R2 = normally open R1 ... R2  
 N = neutral conductor N (common terminal block)  
 PE = protective conductor PE (common terminal block)
- Relay R3 and R4 are electromechanical relays:  
 R3, R4 = normally open R3, R4  
 N = neutral conductor N (common terminal block)  
 PE = protective conductor PE (common terminal block)
- Relay R5 is a floating / potential-free relay with change-over contact:  
 R5-M = center contact  
 R5-A = normally open  
 R5-R = normally closed  
 N = neutral conductor N (common terminal block)  
 PE = protective conductor PE (common terminal block)

R1	R2	R3	R4	R5
P1	Pc	VR	operating- / error relay	operating- / error relay

### 3.1.2 Sensors

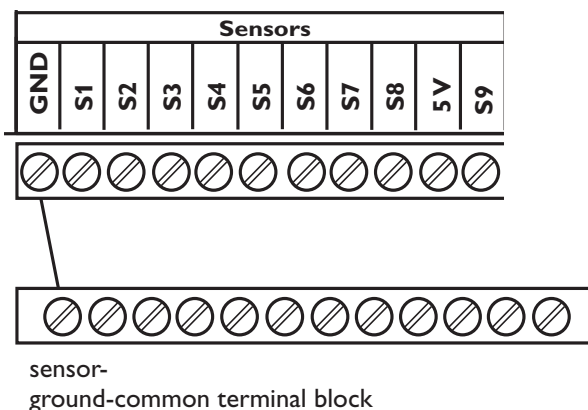

The controller is equipped with 9 sensor inputs in total. The sensor ground connection (GND) is at the sensor ground terminal block. The temperature sensors have to be connected to terminals S1 ... S6 and GND (either polarity).

The power supply of sensors S7 and S8 is carried out at terminal 5V (Us).

S1	S2	S3	S4	S5	S6
T-HW	T-S	T-St	T-R	---	---

S7	S8	5V	S9
T-CW	dV	Us	On / Off
0-3,8V	0-3,8V	+5V	
yellow	white	brown	

### 3.1.3 Data communication / bus

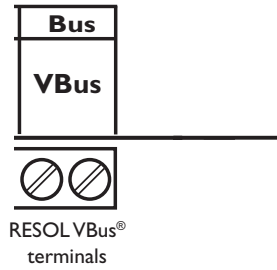

The controller is equipped with the RESOL VBus® for data transfer with and power supply to external modules. The connection is carried out at the two terminals marked „VBus“ (either polarity).

### 3.1.4 Mains supply

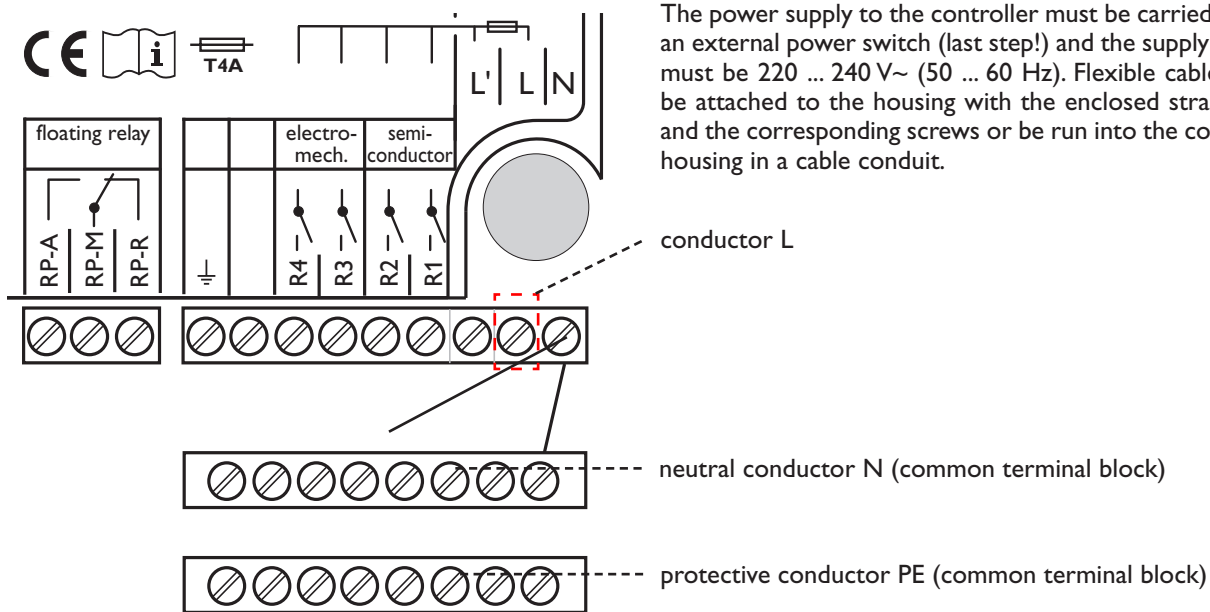

The power supply to the controller must be carried out via an external power switch (last step!) and the supply voltage must be 220 ... 240 V~ (50 ... 60 Hz). Flexible cables must be attached to the housing with the enclosed strain relief and the corresponding screws or be run into the controller housing in a cable conduit.

### 3.1.5 Flashing codes

green:	normal operation
red/green flashing:	initialisation (10 sec.)
green flashing:	manual operation
red flashing:	sensor defective

### 3.1.6 Menu structure

<b>MAIN MENU:</b>
MERS. VALUES
REPORTS
BALANCES
SETTINGS
OPTIONS
MANUAL OPERATION
USER CODE
EXPERT

<b>MERS. VALUES:</b>
BACK
T-HW
T-S
TST
T-R
T-CW
T-C
TAP
TIME
LOAD. PUMP
CIRCULATION
RETURN VALVE
RELAY 1-5
SEN. 1-9

<b>REPORTS</b>
BACK
EVERYTHING OK
INITIALIZATION
ISENSOR FAILURE
>>MERS. VALUES
IEEPROM
IRTC
-MANUAL OPERAT.
-CIRCULATION
-EMERGENCY OPER.
-BLOCK. PROTECT.
-EXTERNAL OFF
-RETURN DIV.
-HOT WATER GEN.
SW-VERSION

<b>BALANCES:</b>
BACK
OPERATION
VOLUME
VOL. MAX
LOAD. PUMP
CIRC.-P.
T-S MIN
T-S MAX
T-CW MIN
T-CW MAX
HEAT QTY (WH)
HEAT QTY (KWH)
HEAT QTY (MWH)

<b>SETTINGS:</b>
BACK
HOTWATER
BP ON
BP OFF
BP WAIT
CIRC. RUN
CIRC. WAIT
CIRC. SENSOR
CIRC. HYST.
CIRC. MIN
WEEK TIMER CIRC.
ΔT-RD ON
ΔT-RD OFF
EMERGENCY
TIME
LANGUAGE

<b>OPTIONS:</b>
BACK
CIRCULAT.
RETURN DIV.
ERROR REL.
SIGNAL REL.
EXTERN OFF
EMERGENCY

<b>MANUAL OPERATION:</b>
BACK
RELAY 1-5

<b>EXPERT:</b>
BACK
BP TIME
TAP. MIN
ROT. MIN
DEFAULT SETTINGS
GRUNDFOS SENSOR
ALGORITHM

**EXPERT:**  
Please ask the system provider before changing any values.

**4. Overview of functions and options**

Menu	Description	Type	Range	Factory setting	Page
<i>T-HW</i>	Temperature - domestic hot water	M	-50,0 ... 250,0 °C	-----	5
<i>T-CW</i>	Temperature - cold water	M	-50,0 ... 250,0 °C	-----	5
<i>T-S</i>	Temperature - heat source	M	-50,0 ... 250,0 °C	-----	5
<i>T-R</i>	Temperature - return	M	-50,0 ... 250,0 °C	-----	8
<i>T-ST</i>	Temperature - store	M	-50,0 ... 250,0 °C	-----	8
<i>T-C</i>	Temperature - circulation	M	-50,0 ... 250,0 °C	-----	7
<i>TAP</i>	Flowrate	M	0 ... 9999 l/h	-----	5
<i>LOAD. PUMP</i>	Speed - loading pump	M	Off / 0 ... 100 %	-----	5
<i>CIRCULATION</i>	Status - circulating pump	M	Off ... On	-----	5, 6, 7
<i>RETURN VALVE</i>	Status - return connection	M	Off ... On	-----	8
<i>RELAY 1-5</i>	Operating mode R1-R5	P	On / Auto / Off	Auto	9
<i>SEN. 1-9</i>	Sensors 1-9	M	-50,0 ... 250,0 °C		13
<i>-MANUAL OPER.</i>	Status - manual operation function	S		-----	13
<i>CIRC. RUN</i>	Circulating time	P	1 Min. ... 10 Min.	2 Min.	6
<i>CIRC. WAIT</i>	Circulating break time	P	0 Min. ... 20 Min.	10 Min.	6
<i>CIRC. HYST.</i>	Heat up hysteresis - circulation	P	0,5 ... 10 K	5,0 K	7
<i>CIRC. MIN</i>	Minimum temperature - circulation	P	10 ... 60 °C	40 °C	7
<i>WEEK TIMER CIRC.</i>	Weekly timer - circulation	P	Mo. 00:00 ... So. 23:59		7
<i>CIRCULT.</i>	Circulation option	P	No/Demand/Therm.	no	5, 6, 7
<i>-CIRCULATION</i>	Status - circulation function	S		-----	13
<i>RETURN DIV.</i>	Return - connection option	P	yes ... no	no	5
<i>ΔT-RD ON</i>	Switch-on difference - return valve	P	0,0 ... 25,0 K	5,0	8
<i>ΔT-RD OFF</i>	Switch-off difference - return valve	P	0,0 ... 25,0 K	3,0	8
<i>-RETURN DIV.</i>	Status - return connection	M			13
<i>ERROR. REL.</i>	Error relay option	P	no ... R4/R5	no	5, 9
<i>SIGNAL REL.</i>	Operating relay option	P	no ... R4/R5	no	5, 9
<i>EXTERN OFF</i>	External shutdown option	P	yes ... no	no	5, 9
<i>-HOT WATER GEN.</i>	Status - hot water generation function	S		-----	13
<i>OPERATION</i>	Operating days - controller	B	0 ... 99999 Tg.	0	9
<i>VOLUME</i>	Draw off quantity	B	0,0 ... 9999,9 m3	0,0	9
<i>VOL. MAX</i>	Maximum flow rate	B	0 ... 9999 l/h	0	9
<i>LOAD. PUMP</i>	Operating hours - loading pump	B	0 ... 99999 h	0	9
<i>CIRC.-P.</i>	Operating hours - circulating pump	B	0 ... 99999 h	0	9
<i>T-S MIN</i>	Minimum temperature source	B	-50,0 ... 250,0 °C	250,0 °C	9
<i>T-S MAX</i>	Maximum temperature source	B	-50,0 ... 250,0 °C	-50,0 °C	9
<i>T-CW MIN</i>	Minimum temperature - cold water	B	-50,0 ... 250,0 °C	250,0 °C	9
<i>T-CW MAX</i>	Maximum temperature - cold water	B	-50,0 ... 250,0 °C	-50,0 °C	9
<i>HEAT QTY</i>	Energy - hot water	B	0 ... 999	Wh/kWh/MWh	9
<i>EMERGENCY</i>	Emergency operation option	P	yes ... no	no	5, 9
<i>EMERGENCY</i>	Emergency operation pump speed	P	12 ... 100 %	100 %	9
<i>-EMERGENCY OPERAT.</i>	Status - emergency operation	S		-----	13
<i>ISENSOR FAILURE</i>	Error message - sensor	S			13

Menu	Description	Type	Range	Factory setting	Page
<i>HOTWATER</i>	Set temperature - domestic hot water	P	45 ... 65 °C	55 °C	5
<i>BP ON</i>	Start blocking protection	P	00:00-23:59	06:00	5
<i>BP OFF</i>	Stop blocking protection	P	00:00-23:59	20:00	5
<i>BP WAIT.</i>	Draw off break	P	30 Min ...6 h	4 h	5
<i>-BLOCK. PORT.</i>	Status - blocking protection function	S			13
<i>BP TIME</i>	Blocking protection time	P	1 s ... 10 s	4 s	13
<i>ROT. MIN.</i>	Minimum speed	P	12 % .. 100 %	12 %	13
<i>START IMP.</i>	Start impulse	P	1 s .. 5 s	1 s	13
<i>TAP MIN.</i>	Draw off detection	P	30 l/h .. 300 l/h	90 l/h	13
<i>MX. FLOW</i>	Maximum flow rate	P	0 l/h .. 9999 l/h	1550 l/h	13
<i>ΔT-REG.-MIN.</i>	Hysteresis - set value overrun	P	0 K .. 10 K	5 K	13
<i>ΔT-REG.-EIN</i>	Hysteresis - set value underrun	P	0 K .. -25 K	-5 K	13
<i>TIME</i>	Time	P	Mo. 00:00 ...Su. 23:59		13
<i>DEFAULT SETTINGS</i>	Factory settings	P	yes ... no	no	13

**Types:**

Parameter	P,
Balance value	B
Measured value	M
Status value	S

---

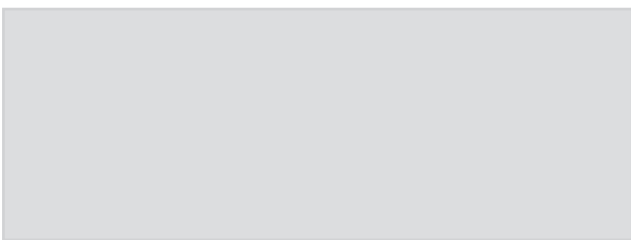
**Distributed by:****RESOL - Elektronische Regelungen GmbH**

Heiskampstraße 10

45527 Hattingen / Germany

Tel.: +49 (0) 23 24 / 96 48 - 0

Fax: +49 (0) 23 24 / 96 48 - 755

[www.resol.de](http://www.resol.de)[info@resol.de](mailto:info@resol.de)**Important notice:**

We took a lot of care with the texts and drawings of this manual and to the best of our knowledge and consent. As faults can never be excluded, please note: Your own calculations and plans, under consideration of the current standards and DIN-directions should only be basis for your projects. We don't offer a guarantee for the completeness of the drawings and texts of this manual - they only represent some examples. They can only be used at your own risk. No liability is assumed for incorrect, incomplete or false information and / or the resulting damages.

**Please note:**

The design and the specifications are to be changed without notice. The illustrations may differ from the original product.

**Reprinting / copying**

This mounting- and operation manual including all parts is copyrighted. Another use outside the copyright requires the approval of RESOL - Elektronische Regelungen GmbH. This especially applies for copies, translations, micro films and the storage into electronic systems.

Editor: RESOL - Elektronische Regelungen GmbH