

FlowCon B - Manual

Installation

Operation

Commissioning



48002540

Thanks for buying this RESOL product.
Read this manual carefully to get the best performance from this unit.

FlowCon B

US/CA
manual

www.resol.de

Contents:

Technical data and operation.....	3	3. Draining the system	6
Security advice	2	3.1 Emptying by the filling pump	6
1. Installation.....	4	4. Commissioning / Operating mode	7
1.1 Mounting the pump station	4	5. Non-return valves.....	7
1.2 Integration of DeltaSol® B / BS / BS Plus	5	6. Connection-set for expansionball	7
2. Filling and flushing the system	6		

Security advice

Please pay attention to the following security advice in order to avoid danger and damage to people and property.

Instructions

Attention should be paid

- to the statutory provisions for prevention of industrial accidents,
- to the statutory provisions for environmental protection,
- to the Health and Safety at Work Act 1974
- to Part P of the Building Regulations 2005
- to BS7671 Requirements for electrical installations and relevant safety regulations of DIN, EN, DVGW, TRGI, TRF and VDE.

This instruction is exclusively addressed to authorised skilled personnel.

- Only qualified electricians should carry out electrical works.
- Initial installation should be effected by named qualified personnel

Declaration of conformity

We, RESOL Elektronische Regelungen GmbH, D-45527 Hattingen, declare under our sole responsibility that our product FlowCon B complies with the following standards:

EN 55 014-1

EN 60 730-1

According to the regulations of the above directives, the product is labelled with **CE**:

89/336/EWG

73/ 23/EWG

Hattingen, 04.07.2007

RESOL Elektronische Regelungen GmbH,

ppa. Gerald Neuse

- Prepared for integration of the controller *DeltaSol*® B / BS / BS Plus
- Dial thermometer for feed flow and return flow
- Innovative design
- Return line with ball valve and deactivatable non-return-valve
- Integrated flowmeter
- Security device with safety valve and manometer
- KFE-cock for filling and flushing the system
- Wall mounting with screws and dowels
- Heat insulation



Technical data:

Circulating pump:	WILO Star S16u/15
Nominal size	approx. 240 x 515 mm (incl. insulation)
Material:	Fittings brass, seals teflon/ viton, insulation EPP
adm. max. temp.:	+220 °F (+ 110 °C), at short-term up to +356 °F (+180 °C)
Operation pressure:	max. 10 bar
Spring pressure of non-return valve:	2 x 200 mm water column (total = 400 mm WC)
Flowmeter:	1...13 l/min (standard) or 0,5 ... 5 l/min

1. Installation

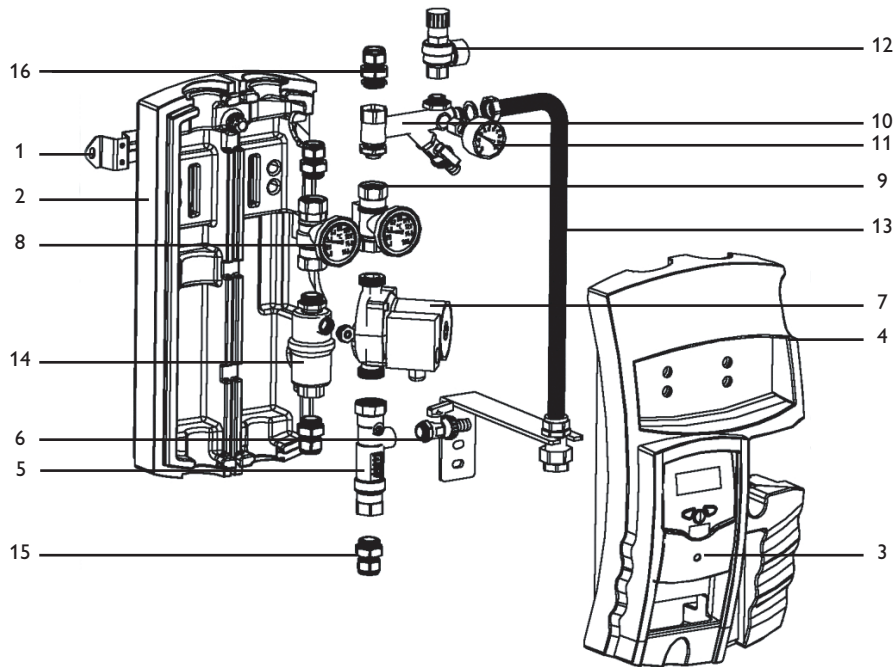

- | | | | |
|---|---|----|---|
| 1 | Wall mounting bracket | 9 | Return ball valve with integrated thermometer |
| 2 | Insulation rear part | 10 | Safety head piece with Fill/Drain valve |
| 3 | Controller | 11 | Manometer |
| 4 | Insulation front part | 12 | Safety valve 6 bar |
| 5 | Flowmeter | 13 | Optional: expansion tank set |
| 6 | Fill/Drain valve | 14 | Optional: Airstopp |
| 7 | Pump | 15 | Optional: Cutting ring screw for copper tube |
| 8 | Flow ball valve with integrated thermometer | | |

1.1 Mounting of the pump station

- The complete pump station must be taken from the wrapping. The front insulation jacket of the pump station must be pulled forward firmly so that the thermometers release from the immersion sleeves.
 - The manometer (2) must be inserted into the valve without using hemp or other sealants. The manometer must be screwed as far as it will go and then slackened so that the display is correctly aligned.
 - Determine the mounting place for the expansionball and install the ADG-connection set.
- Please fix the pump station with the rear insulation jacket in place!**
- Please determine the mounting place of the pump station, align the station to the wall and mark the hole center distance for attachment (1, hole center distance 150 mm). Drill the holes for the enclosed dowels, insert dowels and fix the pump station to the wall with the enclosed fastening screws (plate screws 6 x 60 mm) and a positive cross recessed screwdriver.

All fittings are preassembled by RESOL. Please check all fittings are correctly tightened when commissioning the pump station.

1.2 Integration of the controller *DeltaSol*® B / BS / BS Plus



front insulation jacket
front view

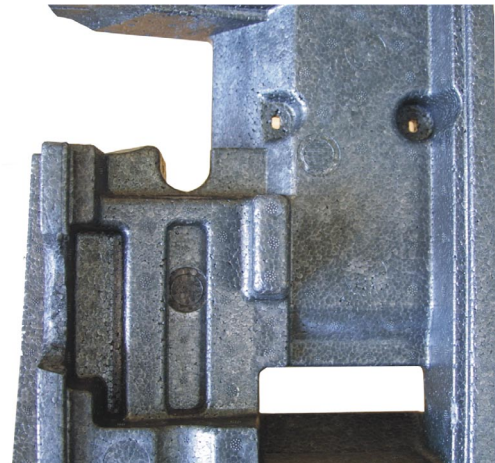

insulation jacket
back view

- Draw off the front insulation jacket, start from the top (hold the thermometers).
- Pull the front controller covers under the insulation jacket.
- Insert the controller into the provided recess of the insulation and fix it by the fastening screws (3 x 30) and large washers.
- Electrical connections (plug, sensor- and relay-connections) must be made at the controller according to the enclosed manual.
- The cables, especially that of the pump, must be of sufficient length so that the front jacket can be removed without damaging the controller. Please ensure that the cables do not contact with hot pipes !

More detailed information for installation of the controller can be taken from the manual *DeltaSol*® B / BS / BS Plus.

2.1 Filling and flushing of the system

1. The ball valve (4) below the pump must be closed.
2. Open (KFE-cock) (5) and fill the system using a separate pump and allow the medium to flow through the system until it discharges through KFE-cock (6), Continue until clear medium appears.
3. Open the ball valve (4) below the pump, so that all air is flushing out of the system.
4. For further work steps please see item 4 „commissioning“.

Attention:

**It is not possible to completely empty the collectors!
If the system is filled with water frost damage will occur.**

3. Draining the system

1. Open both non-return valves in the ball valves (3) by using a combination wrench SW14 for opening halfway the ball valve (see non-return valves).
2. Fit a drain cock at the lowest point of the system.
3. Open any air vents at the collector in order to allow air into the system and the collectors to drain.

3.1 Emptying the system by using a filling pump

1. Open both non-return valves in the ball valves (3) by using a combination wrench SW14 for opening halfway the ball valve (see non-return valves).
2. Connect the pump to the drain cock (6) below the circulation pump.
3. Open the drain cock and de-pressurise the system.
4. Start up the pump for emptying the system and immediately open the drain cock (5) above the circulation pump (manometer) so that air can be aspirated.

4. Commissioning / Operation mode:

1. Close the KFE-cock and increase the system pressure to 5 bar by means of an external filling pump via KFE-cock (5) (depending on the version).
2. Close the filling cock (5); open all ball valves and/or valves of the system or put them to the operation mode „EIN“. Carry out a pressure test of all system joints.
3. Let the system circulate for a moment and again carry out the pressure test (set the controller to manual operation).
4. Open the venting valves at airscoop (repeated venting!).
5. Adjust system pressure to 3 bar operation pressure! The volume flow of the system cannot be adjusted.
6. The solar system must again be vented (at airscoop) after some operating hours. After venting the system, please control the pressure of the system and if necessary, refill heat transfer medium.

5. Non-return valves

The non-return valves are integrated into the thermometer ball valves and have a opening pressure of 200 water column each.

1. Both non-return valves must be opened for filling, exhausting and flushing the system. They can be opened by using a combination wrench SW14 for opening halfway each ball valve. The ball of the ball valve impresses the non-return valve.
2. The ball valves must be **completely opened** for operation of the system.

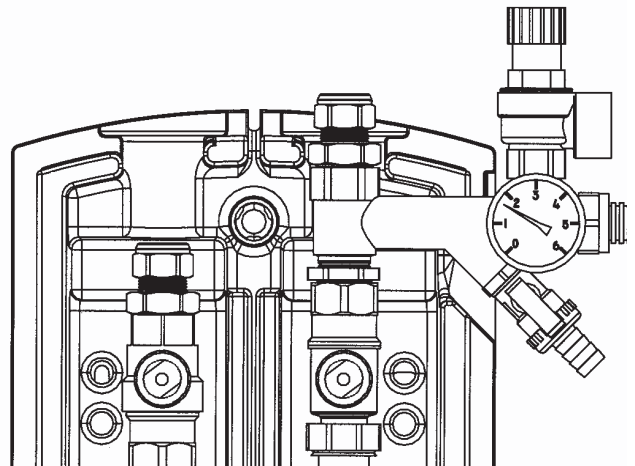

6. Connection set for expansionball (not included in delivery)

The expansionball-set consists of high-steel corrugated tube of 0,5 m length with sleeve nuts on both sides, flatsealing as well as a connection screwing and a mounting clamp for connection of the expansionball.

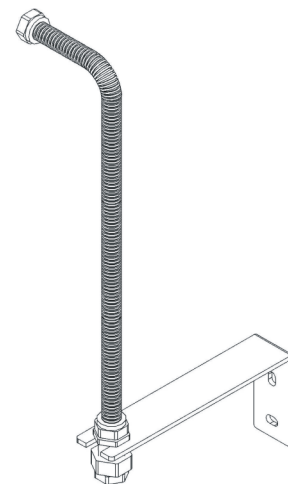

Distributed by:**RESOL - Elektronische Regelungen GmbH**

Heiskampstraße 10
D - 45527 Hattingen

Tel.: +49 (0) 23 24 / 96 48 - 0

Fax: +49 (0) 23 24 / 96 48 - 755

www.resol.de
info@resol.de

Reprinting / copying

This mounting- and operation manual including all parts is copyrighted. Another use outside the copyright requires the approval of Altecnic Ltd.. This especially applies for copies, translations, micro films and the storage into electronic systems. Editor: Altecnic Ltd.

Important notice:

We took a lot of care over the texts and drawings of this manual and to the best of our knowledge and consent. As faults can never be excluded, please note: Your own calculations and plans under consideration of the current norms and DIN-directions should only be basis for your projects. We don't offer a guarantee for the completeness of the drawings and texts of this manual - they only represent some examples. They can only be used on own risk. No liability is assumed for incorrect, incomplete or false information and the resulting damages.

Errors an technical changes excepted.

Notes

Design and specifications are subject to change without notice. Illustrations may differ slightly from production models.