

RESOL DeltaSol[®] BS Pro

Mounting
Connection
Handling
Fault localization
Examples



48002700

Thanks for buying a RESOL product.
Read this manual carefully to get the best performance from this unit.

DeltaSol[®] BS Pro



manual

www.resol.de

Contents

Imprint	2	2.2	System monitoring display	10
Security devices.....	2	2.2.1	Channel indication.....	10
Technical data and function survey	3	2.2.2	Tool bar	10
1. Installation	4	2.2.3	System screen.....	11
1.1 Mounting.....	4	2.3	Blinking codes.....	11
1.2 Electrical wiring.....	4	2.3.1	System screen blinking codes.....	11
1.2.1 Standard solar system.....	5	2.3.2	LED blinking codes.....	11
1.2.2 Solar system and heat exchange	5	3. Commissioning.....	12	
1.2.3 Solar system and after-heating.....	6	4. Control parameter and indication channels	13	
1.2.4 Solar system and store charge in layers	6	4.1 Channel overview.....	13	
1.2.5 2-store-solar-system valve logic	7	4.1.1-5 Indication channels	15	
1.2.6 2-store-solar-system pump logic.....	7	4.1.6-20 Adjustment channels.....	16	
1.2.7 Solar system with 2 collectors	8	5. Tips for fault localization.....	21	
1.2.8 Solar system with after-heating by solid fuel boiler	8	5.1 Miscellaneous.....	22	
1.2.9 Solar system with heating circuit reverse raising	9	6. Accessory	24	
2. Operation and function	10			
2.1 Adjustment buttons	10			

Safety regulations:

Please read the following information carefully before installing and operating the controller. In this way damage to the solar system by wrong installation will be avoided. Please observe that the mounting is adapted to the characteristics of the building, that the local regulations are respected and is conform with the technical rules.

Reprinting / copying

This mounting- and operation manual including all parts is copyrighted. Another use outside the copyright requires the approval of RESOL - Elektronische Regelungen GmbH. This especially applies for copies, translations, micro films and the storage into electronic systems.

Editor: RESOL - Elektronische Regelungen GmbH

Important notice:

We took a lot of care over the texts and drawings of this manual and to the best of our knowledge and consent. As faults can never be excluded, please note:
Your own calculations and plans under consideration of the current norms and DIN-directions should only be basis for your projects. We don't offer a guarantee for the completeness of the drawings and texts of this manual - they only represent some examples. They can only be used on own risk. No liability is assumed for incorrect, incomplete or false information and the resulting damages.

Errors and technical changes excepted.

- System-monitoring-display
- Up to 4 temperature sensors Pt1000
- 9 basic systems selectable
- Heat balancing
- Function control
- User-friendly operation by simple handling
- Housing in outstanding design and compact dimensions, easy to install



Scope of delivery:

- 1 x DeltaSol® BS Pro
- 1 x accessory bag
 - 1 x spare fuse T4A
 - 2 x screws and dowels
 - 4 x strain relief and screws

Additionally enclosed in the full kit:
 2 x sensor FKP6
 2 x sensor FRP6

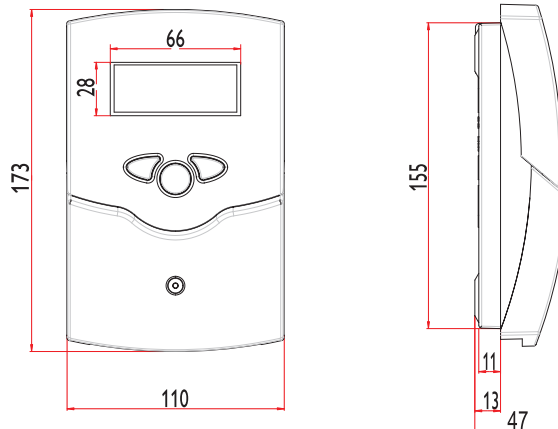

Technical data

Housing:

plastic, PC-ABS and PMMA

Protection type: IP 20 / DIN 40050

Environmental temp.: 32 ... 104 °F

Size: 172 x 110 x 46 mm

Mounting: wall mounting, mounting into patch-panels is possible

Display: System screen for system visualisation, 16-segment display, 7-segment display, 8 symbols for system status and operating control lamp

Operation: by 3 pushbuttons in the front of the housing

Functions: Differential temperature controller with optionally add-on system functions. Function control according to BAW-guidelines, operating hours counter for solar pump, tube collector special function and heat quantity balancing.

Inputs: for 4 temperature sensors Pt1000

Outputs: 2 standard-relays

Power supply:

12V=

Total power supply:

4 (2) A 12V=

1. Installation

1.1 Mounting

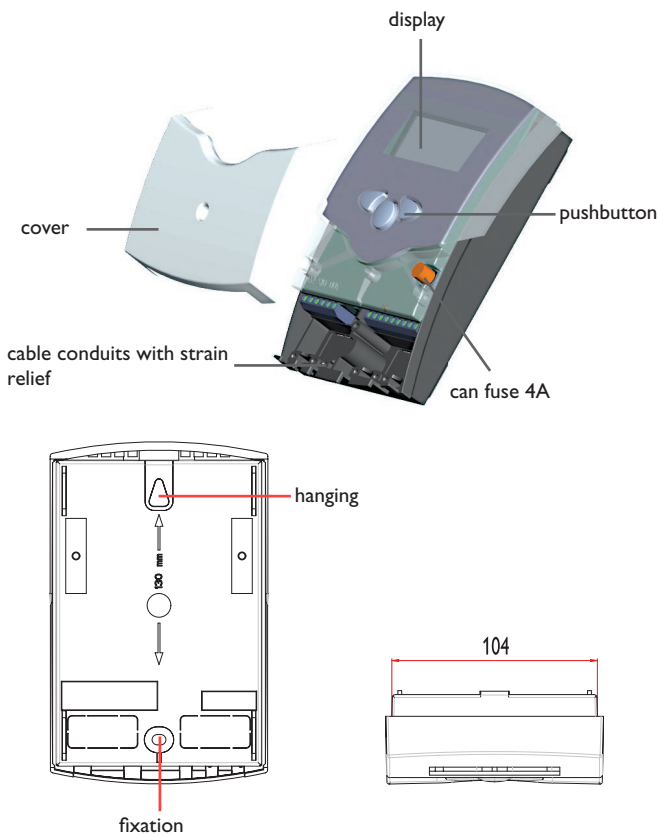

Warning!
Switch-off power supply before opening the housing.

The unit must only be located internally. It is not suitable for installation in hazardous locations and should not be sited near to any electromagnetic field. The controller must additionally be equipped with an all-polar gap of at least 3 mm or with a gap according to the valid installation regulations, e.g. LS-switches or fuses. Please pay attention to a separate laying of the cable lines and installation of ac power supply.

1. Unscrew the cross-recessed screw of the cover and remove it from the housing.
2. Mark the upper fastening point on the underground and pre-mount the enclosed dowel and screw.
3. Hang up the housing at the upper fastening point and mark the lower fastening point on the underground (hole pitch 130 mm), afterwards put the lower dowel.
4. Fasten the housing at the underground.

1.2 Electrical wiring

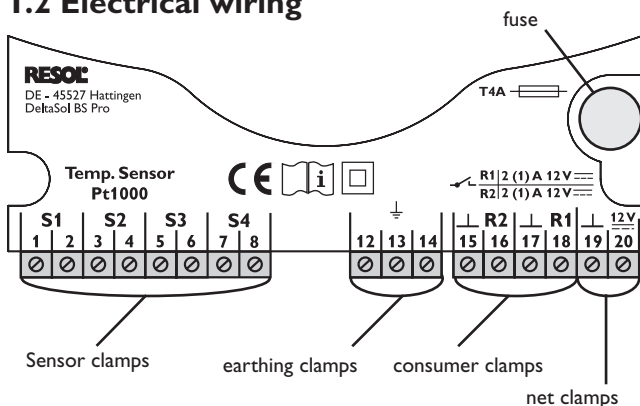

The power supply to the controller must only be made by an external power supply switch (last step of installation!) and the line voltage must be 12 Volt. Flexible lines have to be fixed at the housing by enclosed strain relief supports and screws.

The controller is equipped with 2 standard relays, to which the **consumers** e.g. pumps, valves etc. can be connected:

- Relay 1
18 = conductor R1
17 = neutral conductor N
13 = ground clamp
- Relay 2
16 = conductor R2
15 = neutral conductor N
14 = ground clamp

The **temperature sensors** (S1 up to S4) will be connected to the following terminals independently of the polarity:

- 1 / 2 = Sensor 1 (e.g. Sensor collector 1)
- 3 / 4 = Sensor 2 (e.g. Sensor store 1)
- 5 / 6 = Sensor 3 (e.g. Sensor collector 2)
- 7 / 8 = Sensor 4 (e.g. Sensor store 2)

The **power supply** is effected to the clamps:

- 19 = neutral conductor N
- 20 = conductor L
- 12 = ground clamp



Dangerous voltage on contact!



Electrostatic discharge can lead to damages of electronic components!

1.2.1 Allocation of clamps for system 1

Standard solar system with 1 store, 1 pump and 3 sensors. The sensor S4 / TRF can optionally be used for heat quantity balancing.

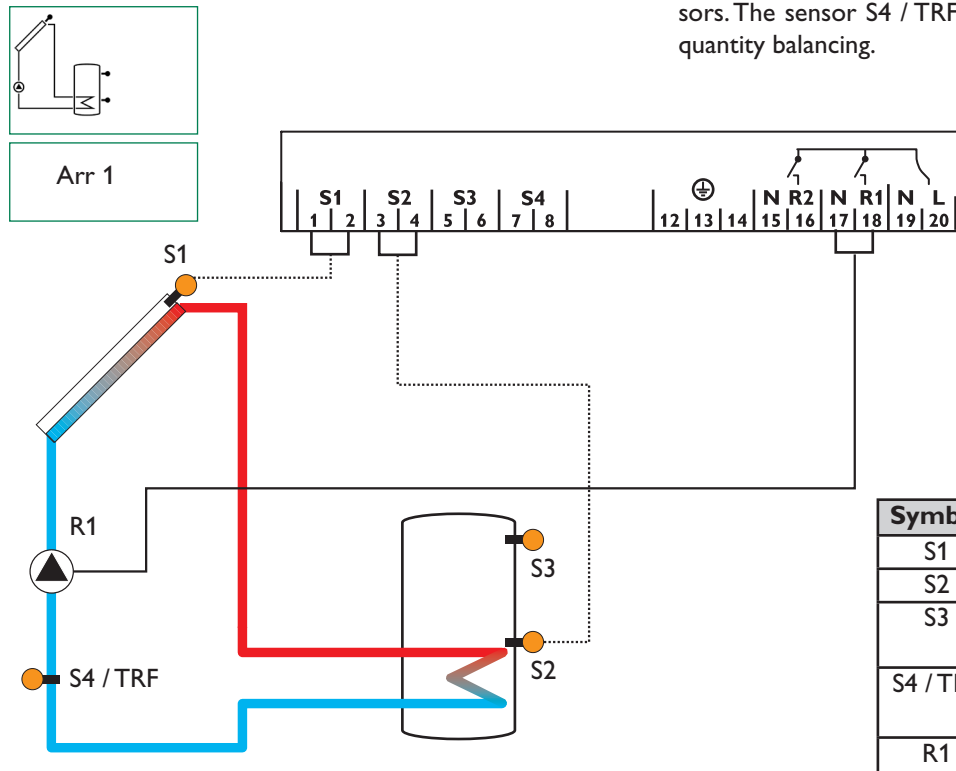

Symbol	Specification
S1	Collector sensor
S2	Store sensor lower
S3	Store sensor at the top (optionally)
S4 / TRF	Sensor for heat quantity measurement (optionally)
R1	Solar pump

1.2.2 Allocation of clamps for system 2

Solar system and heat exchange of existing store with 1 store, 4 sensors and 2 pumps.

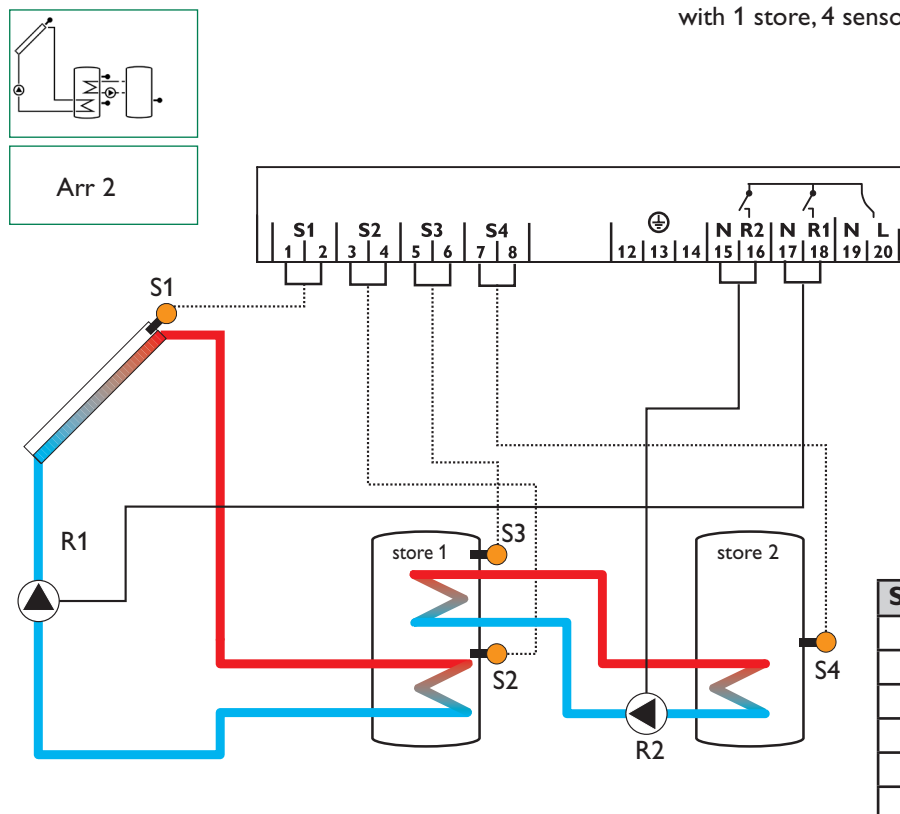

Symbol	Specification
S1	collector sensor
S2	store sensor lower
S3	store sensor at the top
S4	store sensor 2
R1	solar pump
R2	pump for heat exchange

1.2.3 Allocation of clamps for system 3

Solar system and after-heating with 1 store, 3 sensors and after-heating. The sensor S4 / TRF can optionally be used for heat quantity balancing.

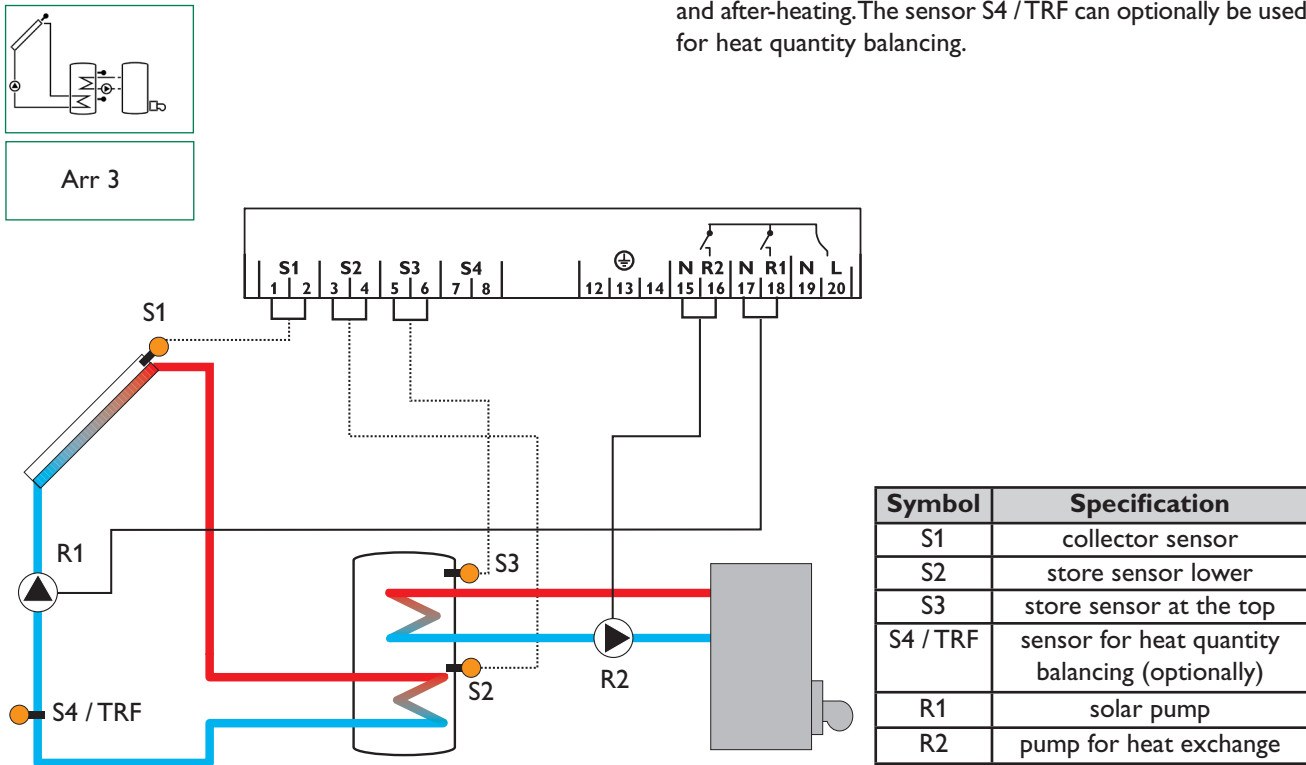

1.2.4 Allocation of clamps for system 4

Solar system and store charge in layers with 1 store, 3 sensors, 1 solar pump and 3-way-valve for store charge in layers. The sensor S4 / TRF can optionally be used for heat quantity balancing.

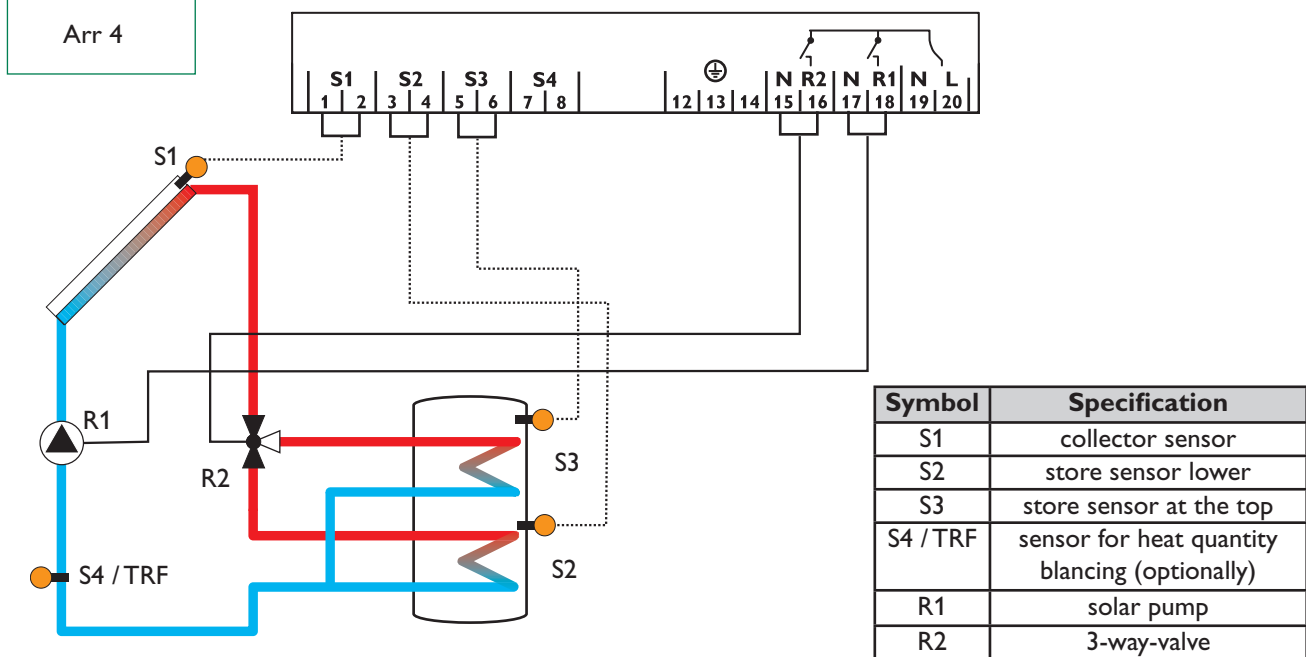

1.2.5 Allocation of clamps for system 5

2-store-solar system with valve logic with 2 stores, 3 sensors, 1 solar pump and 1 3-way-valve. The sensor S4 / TRF can optionally be used for heat quantity balancing.

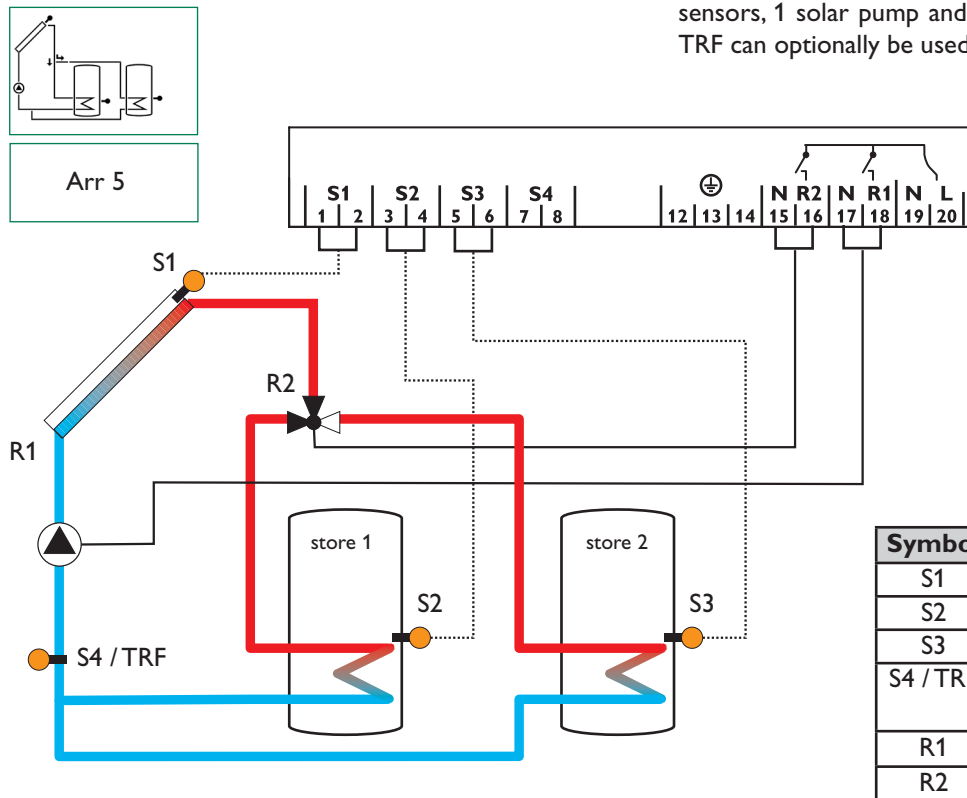

1.2.6 Allocation of clamps for system 6

2-store-solar system with pump logic with 2 stores, 3 sensors and 2 solar pumps.

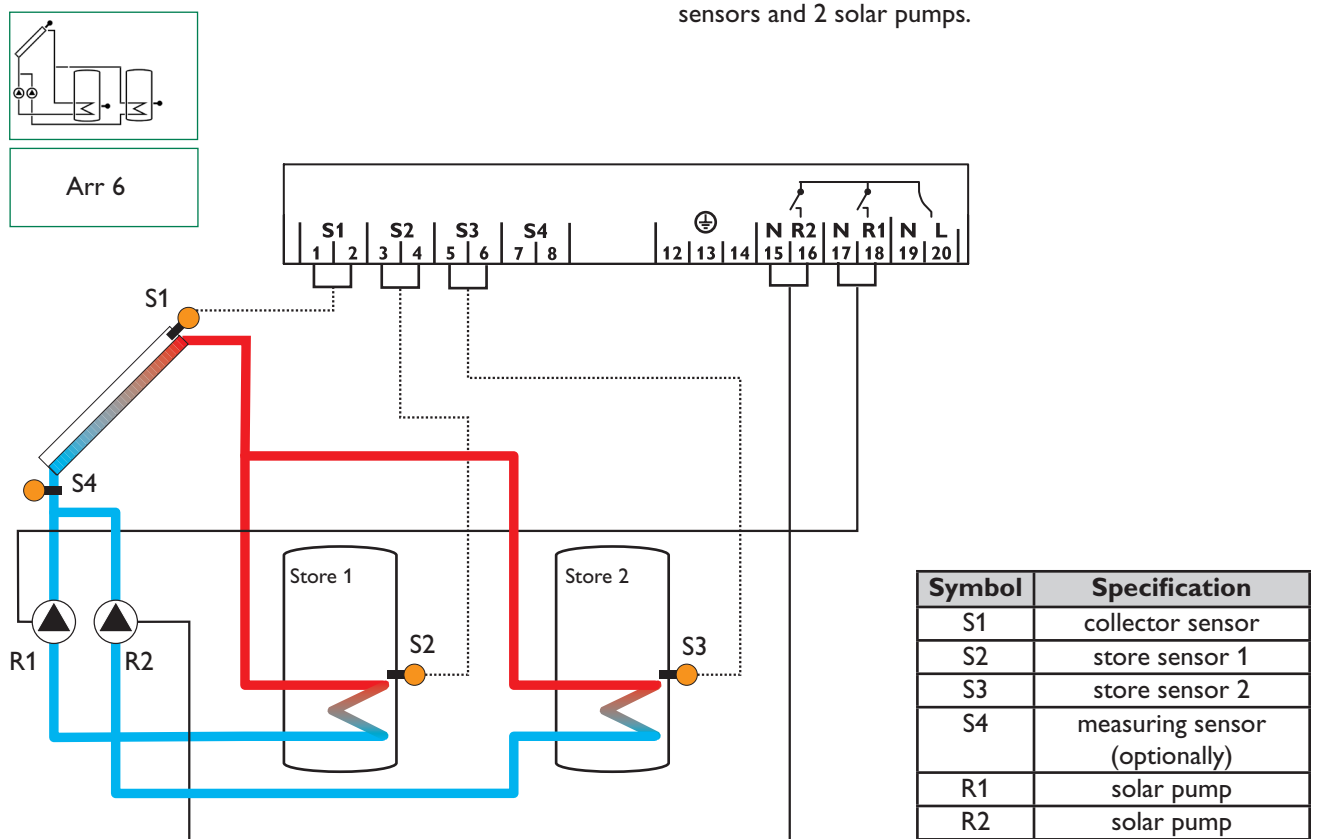

1.2.7 Allocation of clamps for system 7

Solar system with east-west collectors, 1 store, 3 sensors and 2 solar pumps.

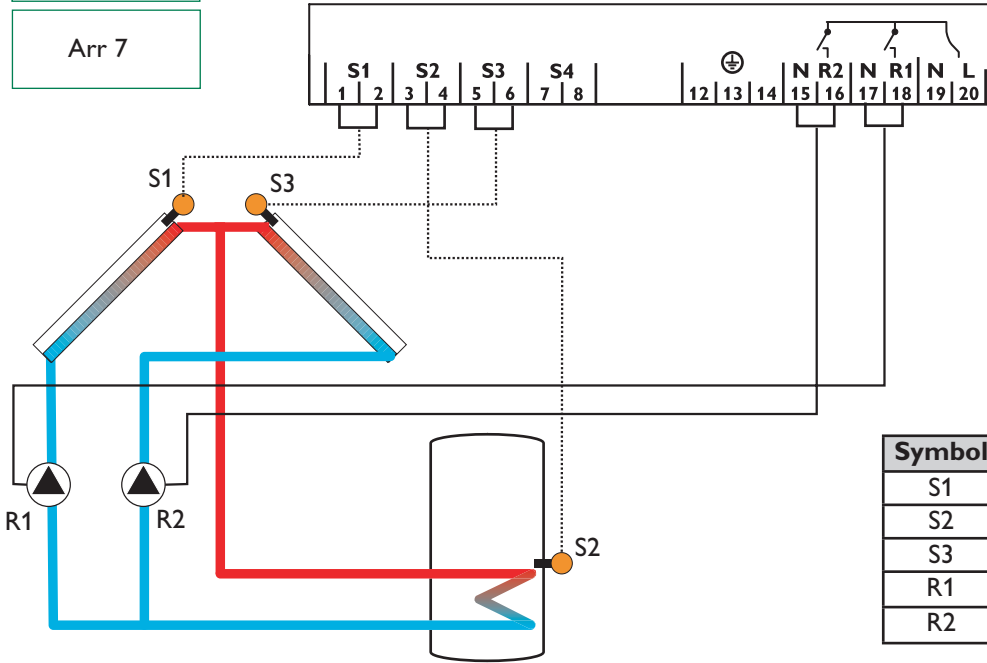
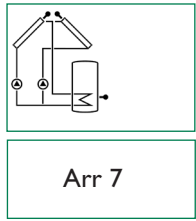

Symbol	Specification
S1	collector sensor 1
S2	store sensor
S3	collector sensor 2
R1	solar pump collector 1
R2	solar pump collector 2

1.2.8 Allocation of clamps for system 8

Solar system with after-heating by solid fuel boiler with 1 store, 4 sensors, 1 solar pump and 1 pump for after-heating.

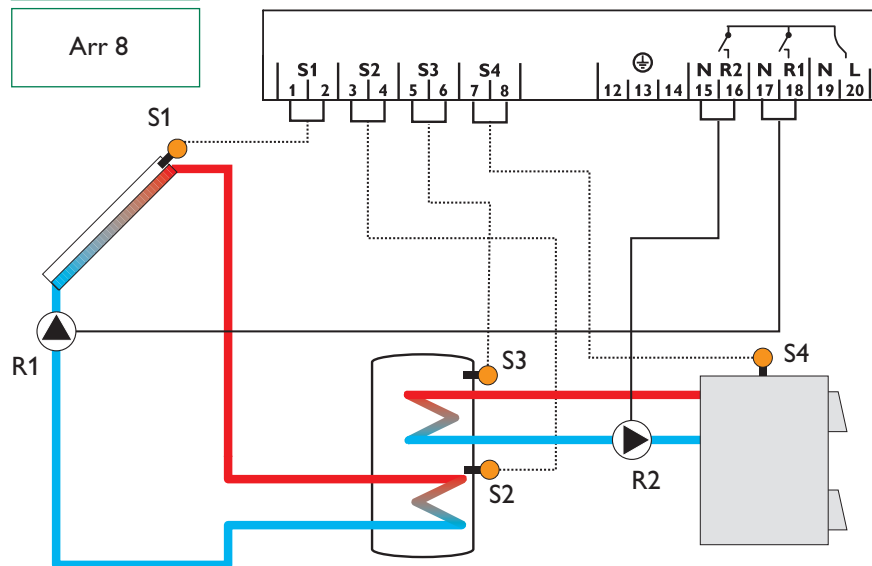
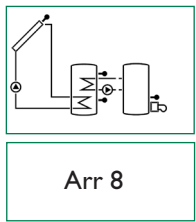

Symbol	Specification
S1	collector sensor
S2	store sensor lower
S3	store sensor at the top
S4	sensor for solid hot fuel boiler
R1	solar pump
R2	pump for solid hot fuel boiler

1.2.9 Allocation of clamps for system 9

Solar system and heating circuit reverse raising with 1 store, 4 sensors, 1 solar pump and 1 3-way-valve for heating circuit reverse raising.

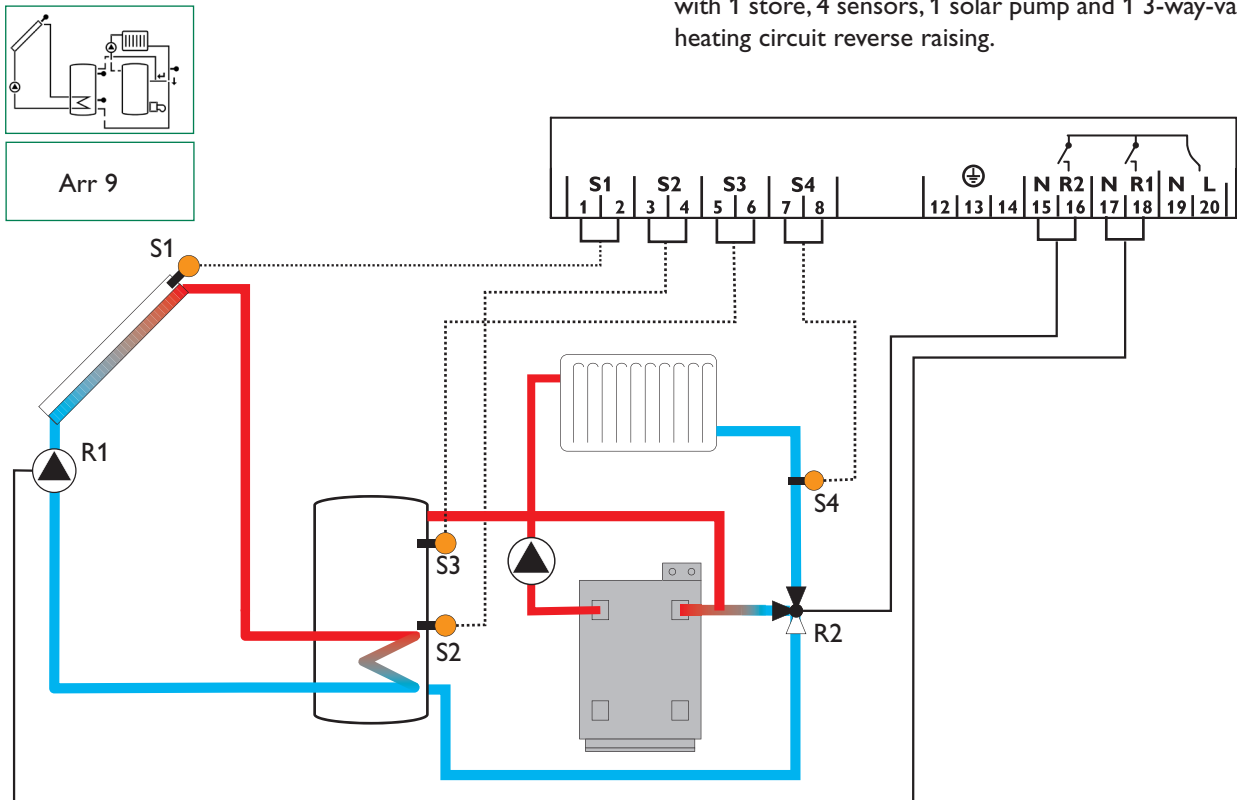

Symbol	Specification
S1	collector sensor
S2	store sensor lower
S3	store sensor at the top
S4	heating circuit return
R1	solar pump
R2	3-way-valve

2. Operation and function

2.1 Pushbuttons for adjustment

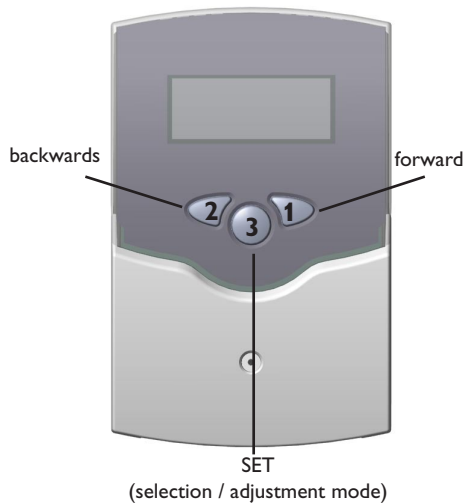

The controller is operated by 3 pushbuttons below the display. The forward-key (1) is used for scrolling forward through the indication menu or to increase the adjustment values. The backwards-key (2) is accordingly used for the reverse function.

For adjustment of last indication channel, keep button 1 pressed for 3 seconds. If an **adjustment value** is shown on the display, **SEt** is indicated. In this case you can press the key „Set“ (3) in order to change into input mode.

Select a channel by keys 1 and 2

Shortly press key 3, so that „SEt“ flashes

Adjust the value by keys 1 and 2

Shortly press key 3, so that „SEt“ permanently appears, the adjusted value is now saved.

2.2 System monitoring display

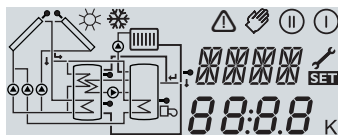

Total Monitoring-Display

The system monitoring display consists of 3 blocks: **indication of the channel, tool bar** and **system screen** (active system scheme).

2.2.1 Channel indication

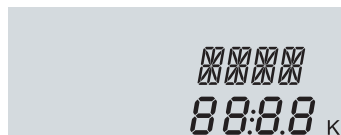

only channel indication

The **indication channel** consists of two lines. The upper line is an alphanumeric 16-segment indication in which mainly the channel names / menu items are shown. In the lower 7-segment indication, the channel values and the adjustment parameters are indicated.

Temperatures and temperature differences are indicated in °F or Ra / K.

2.2.2 Tool bar



only tool bar

The additional symbols of the **tool bar** indicate the current system status.

symbol	standard	flashing
ⓘ	relay 1 activ	
Ⓜ	relay 2 activ	
☀	maximum store limitation active / maximum store temperature exceeded	collector cooling function active reccoling function active
❄	option antifreeze function active	collector minimum limitation active antifreeze function active
⚠		collector security shutdown active or store securtiy shutdown active
⚠ + 🔧		sensor defect
⚠ + 🧤		manual operation active
SEt		an adjustment channel is changed SET-mode

2.2.3 System screen

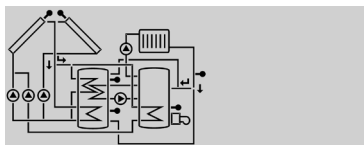

only system screen

The system screen (active system scheme) shows the schemes selected on the controller. It consists of several system component symbols, which are - depending on the current status of the system - either flashing, permanently shown or hidden.

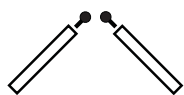
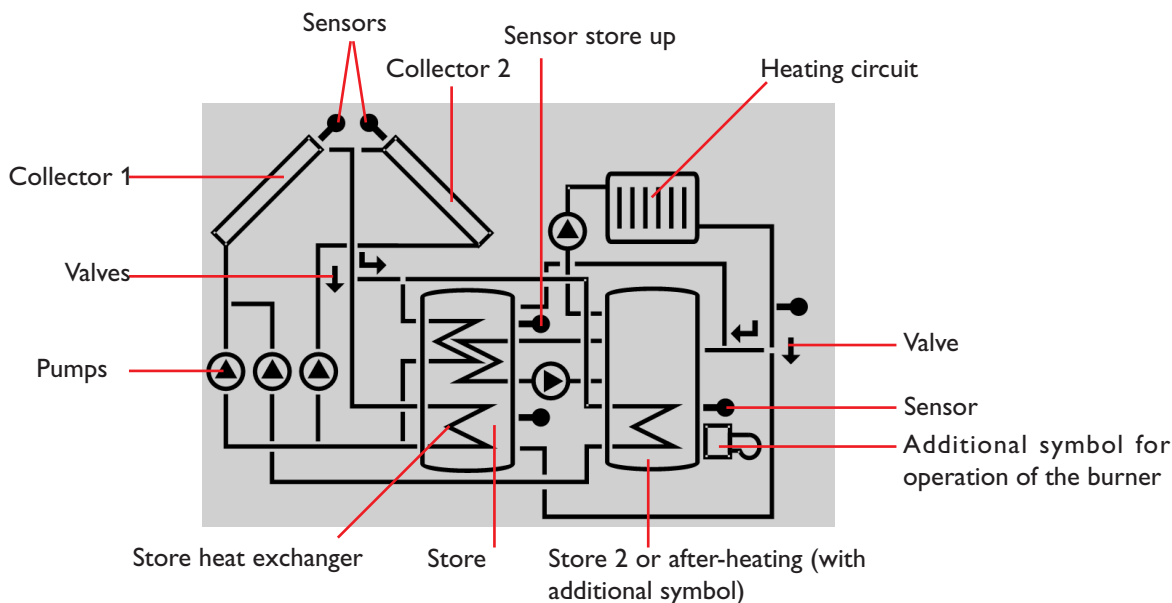

Collectors
with collector sensor

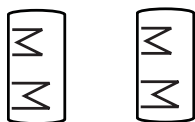

Store 1 and 2
with heat exchanger



3-way-valves
The flow direction or the current breaking capacity are always shown.



Temperature sensor



Heating circuit



Pump

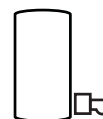

After-heating
with burner symbol

2.3 Blinking codes

2.3.1 System screen blinking codes

- Pumps are blinking during starting phase
- Sensors are blinking if the respective sensor-indication channel is selected.
- Sensors are quickly blinking in case of sensor defect.
- Burner symbol is blinking if after-heating is activated.

2.3.2 LED blinking codes

- Constantly green: everything all right
- Red/green blinking: initialisation phase
- manual operation
- Red blinking: sensor defect
- (sensor symbol is quickly blinking)

3. Commissioning

On commissioning you have to adjust primarily the system scheme

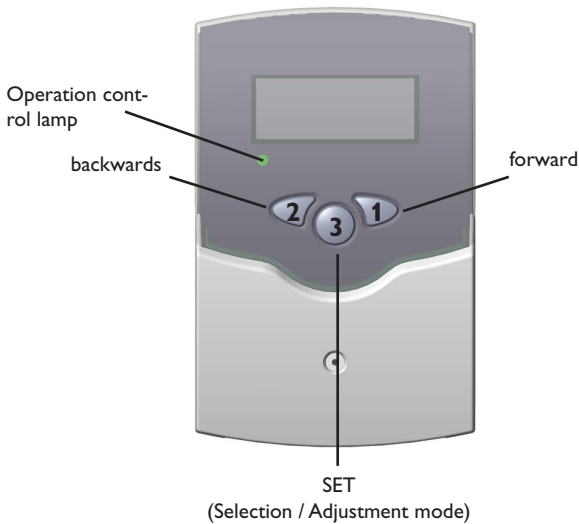

1. Ac power supply must be activated. The controller passes an initialisation phase in which the operating control lamp flashes red and green. After having finished the initialisation, the controller is in automatic operation with factory settings. The preadjusted system scheme is Arr 1.

2. - select Arr

- change into **SET**-mode (see 2.1)
- select the system scheme by Arr-characteristics
- adjustment is saved by pressing button **SET**

Now the controller is ready for operation and should enable an optimum operation of the solar system by the factory settings made.

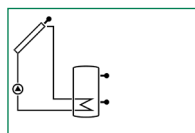

Arr 1

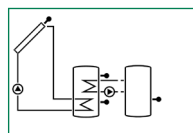

Arr 2

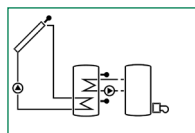

Arr 3

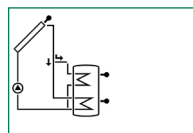

Arr 4

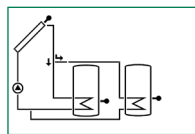

Arr 5

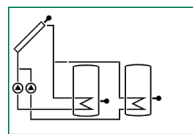

Arr 6

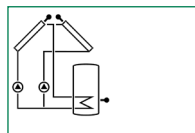

Arr 7

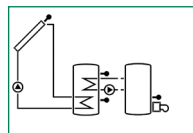

Arr 8

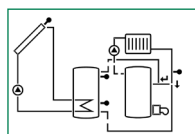

Arr 9

System survey:

Arr 1 : standard solar system

Arr 2 : solar system with heat exchange

Arr 3 : solar system with after-heating

Arr 4 : solar system with store charge in layers

Arr 5 : 2-store solar system with valve logic

Arr 6 : 2-store solar system with pump logic

Arr 7 : solar system with 2 collectors and 1 store

Arr 8 : solar system with after-heating by solid hot fuel boilers

Arr 9 : solar system with heating circuit reverse raising

4. Controller parameter and indication channels

4.1 Channel-overview

Legend:

x

Corresponding channel is available.

x*

Corresponding channel is available if the appropriate option is activated.

Please note:

S3 and S4 are only indicated in case of sensors connected.

①

Corresponding channel is only available if the option heat quantity measurement is **activated** (OHQM).

②

Corresponding channel is only available if the option heat quantity measurement is **deactivated** (OHQM).

MEDT

The channel antifreeze content (MED%) is only shown if there is not used **water or Tyfocor LS / G-LS (MEDT 0 or 3) as antifreeze**. The adjustment of the content of antifreeze does only make sense when using antifreeze components in the solar circuit.

Channel	Arr									Specification	Page
	1	2	3	4	5	6	7	8	9		
COL	x	x	x	x	x	x		x	x	Temperature collector 1	15
COL 1							x			Temperature collector 1	15
TST	x						x			Temperature tank 1	15
TSTU			x	x				x	x	Temperature tank 1 below	15
TST1		x			x	x				Temperature tank 1 below	15
TSTO		x	x	x				x	x	Temperature tank 1 at the top	15
TST2		x			x	x				Temperature tank 2 below	15
TFSB								x		Temperature solid hot fuel boiler	15
TRET									x	Temperature heating circuit	15
COL2							x			Temperature collector 2	15
S3	x									Temperature sensor 3	15
TRF	①		①							Temperature return sensor	15
S4	②		②	②	②	x	x			Temperature sensor 4	15
hP	x			x	x				x	Operating hours relay 1	16
h P1		x	x			x	x	x		Operating hours relay 1	16
h P2		x	x			x	x	x		Operating hours relay 2	16
kWh	①		①	①	①					Heat quantity kWh	16
MWh	①		①	①	①					Heat quantity MWh	16
Arr	1-9									System	12
DT O	x	x	x				x	x	x	Switch-on temperature diff	17
DT1O				x	x	x				Switch-on temperature diff 1	17
DT F	x	x	x				x	x	x	Switch-off temperature diff 1	17
DT1F				x	x	x				Switch-off temperature difference	17
S MX	x	x	x				x	x	x	Maximum temperature tank 1	17
S1 MX				x	x	x				Maximum temperature tank 1	17
DT2O				x	x	x				Switch-on temperature difference 2	17
DT2F				x	x	x				Switch-off temperature difference 2	17
S2MX				x	x	x				Maximum temperature tank 2	17
EM	x	x	x	x	x	x		x	x	emergency temperature collector 1	18
EM1							x			emergency temperature collector 1	18

Channel	Arr									Specification	Page
	1	2	3	4	5	6	7	8	9		
OCX	x	x	x	x	x	x		x	x	option collector cooling collector 1	18
OCX1							x			option collector cooling collector 1	18
CMX	x*	x*	x*	x*	x*	x*		x*	x*	maximum temperature collector 1	18
CMX1							x*			maximum temperature collector 1	18
OKN	x	x	x	x	x	x		x	x	option minimum limitation collector 1	18
OKN1							x			option minimum limitation collector 1	18
CMN	x*	x*	x*	x*	x*	x*		x*	x*	minimum temperature collector 1	18
CMN1							x*			minimum temperature collector 1	18
OCF	x	x	x	x	x	x		x	x	option antifreeze collector 1	18
OCF1							x			option antifreeze collector 1	18
CFR	x*	x*	x*	x*	x*	x*		x*	x*	antifreeze temperature collector 1	18
CFR1							x*			antifreeze temperature collector 1	18
EM2							x			emergency temperature collector 2	18
OCX2							x			option collector cooling collector 2	18
KMX2							x*			maximum temperature collector 2	18
OCN2							x			option minimum limitation collector 2	18
CMN2							x*			minimum temperature collector 2	18
OCF2							x			option antifreeze collector 2	18
CFR2							x*			antifreeze temperature collector 2	18
PRIO				x	x	x				priority	19
tST				x	x	x				stop time	19
tRUN				x	x	x				Circulation time	19
OREC	x	x	x	x	x	x	x	x	x	option recolling	19
OTC	x	x	x	x	x	x	x	x	x	option tube collector	19
DT3O		x						x		switch-on temperature difference 3	17
DT3F		x						x		switch-off temperature difference 3	17
MX3O		x						x		switch-on threshold for maximum temp.	17
MX3F		x						x		switch-off threshold for maximum temp.	17
MN3O		x						x		switch-on threshold for minimum temp.	17
MN3F		x						x		switch-off threshold for minimum temp.	17
AH O			x							switch-on temp. for thermostat 1	20
AH F			x							switch-off temp. for thermostat 1	20
OHQM	x		x	x	x					option WMZ	16
FMAX	①		①	①	①					maximum flow	16
MEDT	①		①	①	①					antifreeze type	16
MED%	MEDT		MEDT	MEDT	MEDT					antifreeze content	16
HND1	x	x	x	x	x	x	x	x	x	manual operation relay 1	20
HND2	x	x	x	x	x	x	x	x	x	manual operation relay 2	20
LANG	x	x	x	x	x	x	x	x	x	Language	20
UNIT	x	x	x	x	x	x	x	x	x	Change over °FAH / °CEL	20
PROG	XX.XX									program number	
VERS	X.XX									version number	

4.1.1 Indication of collector temperatures

COL, COL1, COL2:

Collector temperature
display range: -40...+480 °F



Shows the current collector temperature.

- COL : collector temperature (1-collector-system)
- COL1: collector temperature 1
- COL2: collector temperature 2

4.1.2 Indication of tank temperatures

TST, TSTL, TSTU, TST1, TST2:

Tank temperatures
Display range: -40...+480 °F



Shows the current tank temperature.

- TST : tank temperature (1-tank-system)
- TSTL : tank temperature lower
- TSTU: tank temperature above
- TST1 : temperature tank 1
- TST2 : temperature tank 2

4.1.3 Indication of sensor 3 and sensor 4

S3, S4:

S3, S4:

Sensor temperatures
Display range: -40...+480 °F

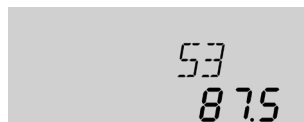

Shows the current temperature of the corresponding additional sensor (without control function).

- S3 : temperature sensor 3
- S4 : temperature sensor 4

Please note:

S3 and S4 are only shown if the temperature sensors are connected.

4.1.4 Indication of other temperatures

TFSB, TRET, TRF:

other measured temperatures
Display range: -40...+480 °F

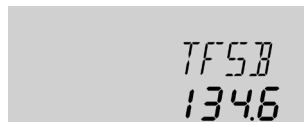

Shows the current temperature of the corresponding sensor.

- TFSB : temperature solid fuel boiler
- TRET : temperature heating reverse raising
- TRF : temperature return flow

4.1.5 Operating hours counter

h P / h P1 / h P2:
operating hours counter
Indication channel

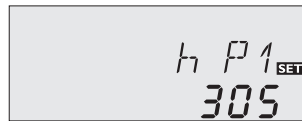

The operating hours counter adds up the solar operating hours of the respective relay (**h P / h P1 / h P2**). Full hours are shown on the display.

After the operating hours are added up, they can be reset. As soon as one operating hours channel is selected, symbol **SET** is permanently shown on the display. The button SET (3) must be pressed for approx. 2 seconds in order to get back into the RESET-mode of the counter. The display-symbol **SET** is blinking and the operating hours will be set to 0. In order to finish the RESET-procedure, the button **SET** must be pressed in order to confirm the data.

In order to interrupt the RESET-procedure, don't press any button for about 5 seconds. The controller returns automatically into the indication mode.

4.1.6 Heat quantity balancing

OHQM: Heat quantity measurement
Adjustment range: OFF...ON
Factory setting: OFF



A heat quantity balancing is possible for the basic systems (Arr) 1, 3, 4 and 5 in conjunction with a flowmeter. You just have to activate the option heat quantity balancing in channel **OHQM**.

FMAX: Volume flow in l/min
Adjustment range 0...20
in steps of 0,1
Factory setting 6,0

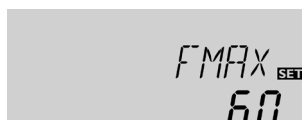

The volume flow readable at the flowmeter (l/min) must be adjusted in the channel **FMAX**. Antifreeze type and concentration of the heat transfer medium are indicated on channels **MEDT** and **MED%**.

MEDT: antifreeze
Adjustment range 0...3
Factory setting 1



Type of antifreeze:

- 0 : water
- 1 : propylene glycol
- 2 : ethylene glycol
- 3 : Tyfocor® LS / G-LS

MED%: Concentration of antifreeze in (Vol-) %
MED% is blinded out by MEDT 0 and 3.
Adjustment range 20...70
Factory setting 45



kWh/MWh: Heat quantity in kWh / MWh
Display channel



The heat quantity transported is measured by the indication of the volume flow and the reference sensor of feed flow S1 and return flow T-. It is shown in kWh-parts in the indication channel **kWh** and in MWh-parts in the indication channel **MWh**. The sum of both channels form the total heat output.

The heat quantity added up can be reset. As soon as one of the display channels of the heat quantity is selected, symbol **SET** is permanently shown on the display. The SET (3) button must be pressed for approx. 2 seconds in order to get back into the RESET-mode of the counter. The display-symbol **SET** is blinking and the value for heat quantity will be set to 0. In order to finish the RESET-procedure, the button **SET** must be pressed in order to confirm the data.

In order to interrupt the RESET-procedure, no button should be pressed for about 5 seconds. The controller returns automatically into the indication mode.

4.1.7 ΔT -regulation

DT O / DT1O / DT2O /

DT3O:

Switch on temperature diff.

Adjustment range 2,0...40,0°Ra

Factory setting 8,0°Ra

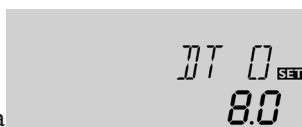

DT F / DT1F / DT2F / DT3F:

Switch-off temperature diff.

Adjustment range 1,0...39,0°Ra

Factory setting 12,0°Ra

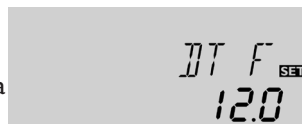

Please note: Switch-on temperature difference DO must be at least 2 °Ra higher than the switch-off temperature-difference DF.

First the controller works in the same way as a standard differential controller. If the switch-on difference (**DT O / DT1O / DT2O**) is reached, the pump is activated. If the adjusted switch-off temperature is underrun (**DT F / DT1F / DT2F**), the controller switches-off.

DT F and **DT S** are locked against each other. **DT S** has to be at least by 0,5°Ra above **DT F**.

4.1.8 Tank maximum temperature

S MX / S1MX / S2MX:

Maximum tank temp.

Adjustment range -40...+480°F

Factory setting 140°F

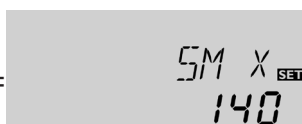

If the adjusted maximum temperature is exceeded, a further loading of the tank is stopped so that a damaging overheating can be avoided. If the maximum tank temperature is exceeded, symbol ☀ is shown on the display.

Please note: The controller is equipped with a security-switch-off of the tank, which avoids a further loading of the tank if 295°F is reached at the tank.

4.1.9 ΔT -controller (solid fuel boiler and heat exchange)

Maximum temperature limitation

MX3O / MX3F:

Maximum temperature limitation

Adjustment range 30...205°F

Factory setting

MX3O 140°F

MX3F 136°F

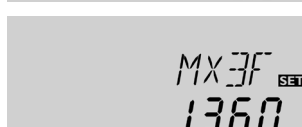
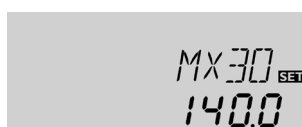

The controller is equipped with an independent temperature differential regulation for which minimum and maximum temperature limitations as well as corresponding switch-on and -off temperatures can be separately adjusted. Only possible for Arr = 2 and 8 (e.g. for solid fuel boilers or heat exchange regulation).

If the adjusted value **MX3O** is exceeded, relay 2 will be deactivated. When falling below **MX3F**, the relay will be switched on again.

Reference sensor:

S3 by Arr 8 (TSTU)

S4 by Arr 2 (TST2)

Minimum temperature limitation

MN3O / MN3F:

Minimum temperature limitation

Adjustment range 30...195°F

Factory setting:

Arr = 2

MN3O 40°F

MN3F 50°F

Arr = 8

MN3O 140°F

MN3F 150°F



If the adjusted value **MN3O** underrun, relay 2 will be deactivated. By falling below **MN3F**, the relay will be switched on again.

Reference sensor:

S4 by Arr 8 (TFSB)

S3 by Arr 2 (TSTU)

Both switch on- and switch off temperature differences **DT3F** and **DT3O** apply parallelly for the maximal- and minimal temperature limit.

4.1.10 Collector temperature limitation Emergency shut down of the collector

EM / EM1 / EM2:

temperature limitation collector
Adjustment range 230...400°F
Factory setting 285°F



If the adjusted collector limit temperature (**EM / EM1 / EM2**) is exceeded the solar pump (R1/R2) is deactivated in order to avoid a damaging overheating of the solar components (collector emergency shutdown). The factory setting for the temperature limitation is 285°F - it can be changed within the adjustment range of 230...400°F. Symbol \triangle is shown on the display (blinking).

4.1.11 System cooling

OCX / OCX1 / OCX2:

Option System cooling
Adjustment range OFF...ON
Factory setting OFF



If the adjusted maximum tank temperature is reached, the solar system switches-off. If now the collector temperature rises to the adjusted maximum collector temperature (**CMX / CMX1 / CMX2**), the solar pump remains activated until this temperature limitation value is again underrun. The tank temperature might continue to rise (subordinated active maximum tank temperature), but only up to 400°F (emergency shutdown of the tank). If the tank temperature is higher than the maximum tank temperature (**S MX / S1MX / S2MX**) and the collector temperature is by at least 10°RA lower than the tank temperature, the solar system remains activated until the tank is cooled down again by the collector and the tubes below the adjusted maximum temperature (**S MX / S1MX / S2MX**) (only by activated **OREC** function).

CMX / CMX1 / CMX2:

collector maximum temperature
Adjustment range 210...380°F
Factory setting 250°F



In case of an activated system \star is shown on the display (blinking). Due to the cooling function, the solar system can be kept operable for a longer period on hot summer days and a thermal release of the collector and the heat transfer medium is ensured as well.

4.1.12 Option collector minimum limitation

OCN / OCN1 / OCN2:

collector minimum limitation
OFF / ON
Factory setting OFF



The minimum collector temperature is a minimum switching temperature which must be exceeded so that the solar pump (R1/R2) is switched-on. The minimum temperature shall avoid a steady starting-up of the solar pump (or solid fuel boiler charging pumps) for low collector temperatures. If the minimum temperature is underrun, \star is shown on the display (blinking).

CMN / CMN1 / CMN2:

col. minimum temperature
Adjustment range 50...195°F
Factory setting 50°F

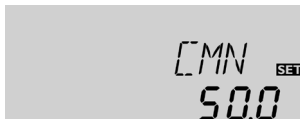

4.1.13 Option antifreeze

OCF / OCF1 / OCF2:

antifreeze function
Adjustment range OFF / ON
Factory setting OFF



The antifreeze function activates the loading circuit between collector and tank if the adjusted antifreeze function is underrun in order to protect the medium against freezing or „thickening“. If the adjusted frost protection temperature is exceeded by 2°F, the loading circuit will be deactivated.

CFR / CFR1 / CFR2:

antifreeze temperature
Adjustment range 15...50°F
Factory setting 40°F



Please note:

As there is only a limited heat quantity of the tank available for this function, the antifreeze function should only be used in regions with few days of temperatures around freezing point.

4.1.14 Oscillating charge

Respective adjustment values:

priority [PRIO]

oscillating break-time [tST]

oscillating charge-time [tRUN]

Factory setting

(1 / Arr 5,6) (2 / Arr 4)

2 min.

15 min.

Adjustment range

0-2

1-30 min.

1-30 min.

The DeltaSol® BS Pro priority logic

priority:



The above-mentioned options and parameters only have a meaning in multi-tank systems (system Arr = 4, 5, 6). If **priority 0** is adjusted, the tanks which show a temperature difference towards the collector are loaded in numerical order (tank 1 or tank 2). Usually only one tank is loaded at this point. For Arr= 5, 6 parallel loading is also possible.

Oscillating break time / oscillating charge time / collector rising temperature

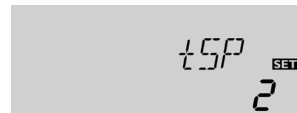

The controller checks the tanks regarding loading facilities (switch-on difference). If the priority tank cannot be loaded, the lower-ranking tank is checked. If the lower-ranking tank can be charged this is effected by the so-called „oscillating charge time“ (**tRUN**). When the oscillating charge time is over the loading is stopped. The controller regulates the increase of the collector temperature. If it increases by the collector rising temperature ($\Delta T\text{-Col } 4^\circ\text{Ra}$, fixed software value), the expired break time is again reset to zero and the oscillating break time starts again. If the switch-on conditions of the priority tank are not reached, the loading of the lower-ranking tank is continued. If the priority switch has reached its maximum temperature, the oscillating charge is not effected.

4.1.15 Recooling function

OREC:

option recooling

adjustment range OFF...ON

Factory setting: OFF

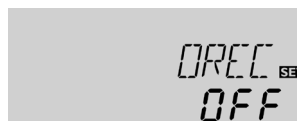

If the adjusted maximum tank temperature (**S MX, S1MX, S2MX**) is reached, the solar pump remains activated in order to avoid an overheating of the collector. The tank temperature might continue to increase but only up to 205°F (emergency shutdown of the tank).

In the evening the solar system continues running until the tank is cooled down to the adjusted maximum tank temperature via collector and pipes.

4.1.16 Tube collector special function

OTC:

Tube collector special function

Adjustment range: OFF...ON

Factory setting: OFF



If the controller measures an increase of 4°Ra compared to the collector temperature stored at last, the solar pump is switched-on to 100 % for about 30 seconds. After the expiration of the solar pump runtime the current collector temperature is stored as a new reference value. If the measured temperature (new reference value) is again exceeded by 4°Ra , the solar pump again switches-on for 30 seconds. If the switch-on difference between collector and tank is again exceeded during the runtime of the solar pump or the standstill of the system, the controller automatically switches over to solar charging.

If the collector temperature drops by 4°Ra during standstill, the switch-on value for the special tube collector function will be recalculated.

4.1.17 Thermostat function
(Arr = 3)

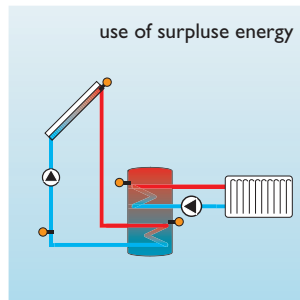
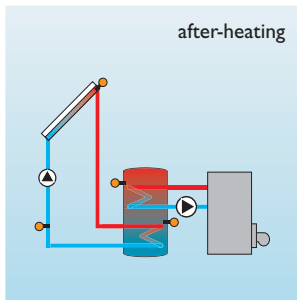

The thermostat function works independently from the solar operation and can e.g. be used for use of surplus energy or an after-heating.

- **AH O < AH F**
the thermostat function is used for after-heating
- **NH O > AH F**
the thermostat function is used for use of surplus energy

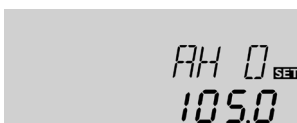

On the display is shown  if the second relay output is activated.

AH O:
Thermostat-switch-on temperature
Adjustment range 30...205°F
Factory setting 105°F



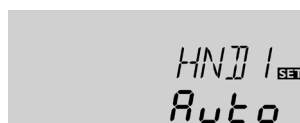

AH F:
Thermostat-switch-off temperature
Adjustment range 30...205°F
Factory setting 115°F

4.1.18 Operating mode

HND1/HND2:
Operating mode
Adjustment range:
OFF,AUTO,ON
Factory setting:AUTO



For control- and service work the operating mode of the controller can be manually adjusted by selecting the adjustment value HND1 / HND2, in which the following adjustments can be made:

- **HND1 / HND2**
Operating mode
OFF : relay off  (flashing) + 
AUTO : relay in automatic operation
ON : relay on  (flashing) + 

4.1.19 Language

LANG:
Adjustment of language
Adjustment range:
dE,En,It,Fr
Factory setting: En



The menu language can be adjusted in this channel.

- dE : German
- En : English
- It : Italiano
- Fr : French

4.1.20 Unit

UNIT:
Adjustment of unit
Adjustment range: FAH, °C
Factory setting: FAH

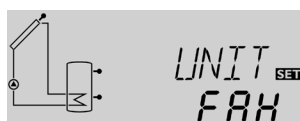

The menu unit can be adjusted:

- °FAH
- °CEL

5. Tips for fault localization

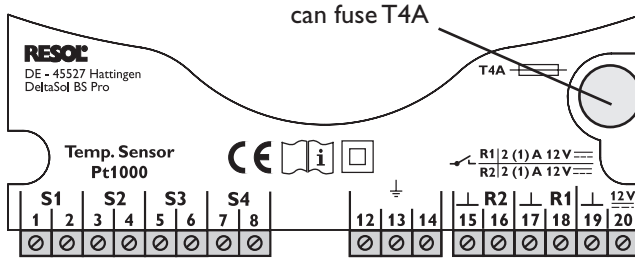

If a malfunction occurs, a notification is given on the display of the controller:

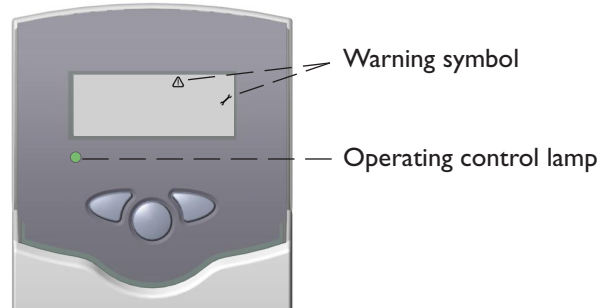

Operating control lamp flashes red. On the display the symbols and appear.

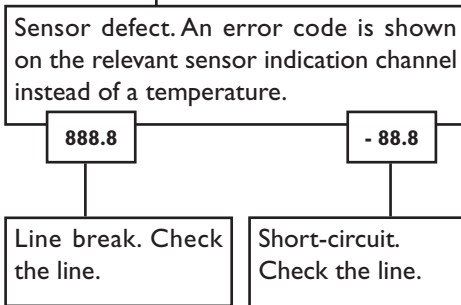

Pt1000-temperature sensors pinched off can be checked with an ohmmeter. In the following the resistance values corresponding to different temperatures are listed.

°F	Ω	°F	Ω
14	961	131	1213
23	980	140	1232
32	1000	149	1252
41	1019	158	1271
50	1039	167	1290
59	1058	176	1309
68	1078	185	1328
77	1097	194	1347
86	1117	203	1366
95	1136	212	1385
104	1155	221	1404
113	1175	230	1423
122	1194	239	1442

Resistance values of the Pt1000-sensors

Operating control lamp off

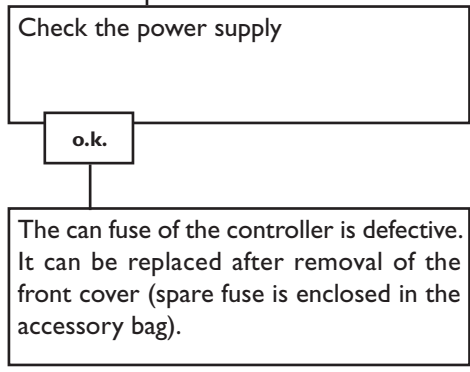

5.1 Various:

Pump is overheated, but no heat transfer from collector to the tank, feed flow and return flow are equally warm, possibly also bubble in the tubes

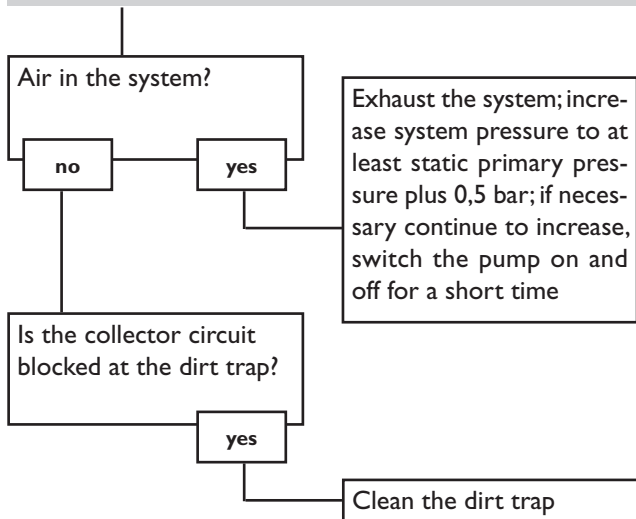

Pump starts for a short moment, switches-on/off repeatedly

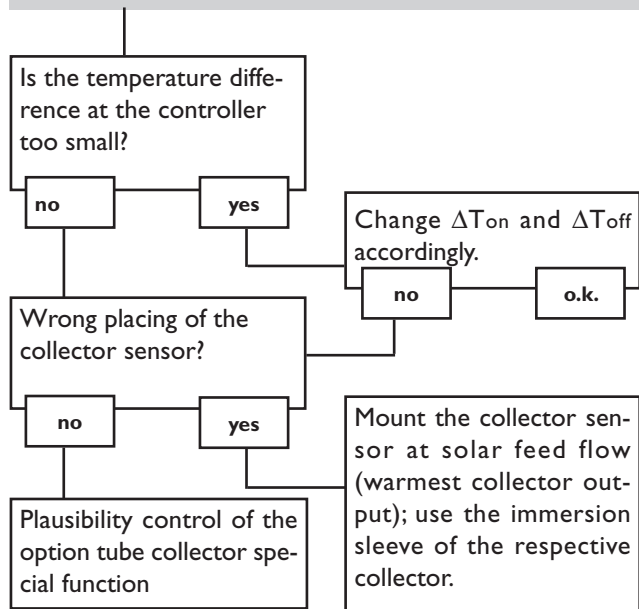

Pump starts up very late and stops working soon.

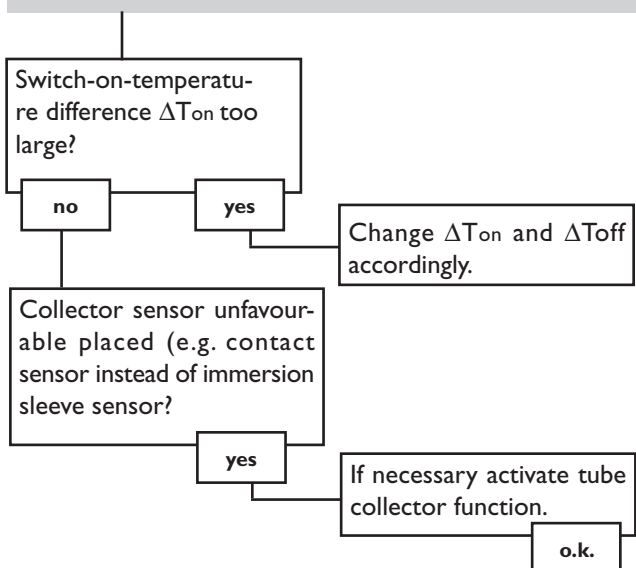

The temperature difference between tank and collector increases enormously during operation; the collector circuit cannot dissipate the heat.

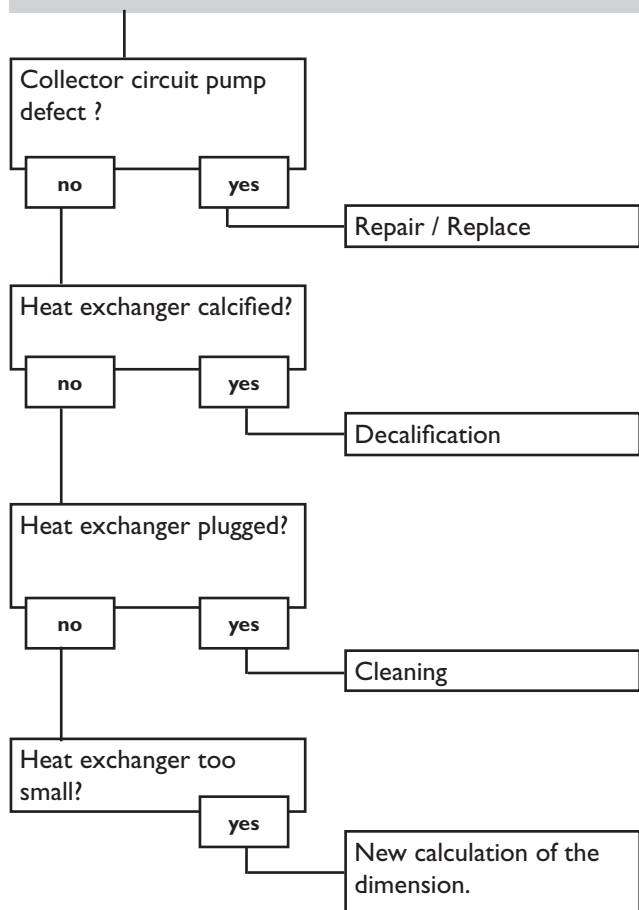

6. Accessory

Sensors

Our product range includes high-precision platinum temperature sensors, flatscrew sensors, ambient temperature sensors, indoor temperature sensors, cylindrical clip-on sensors and irradiation sensors, also to be used as full sensors with sensor pocket.



Overvoltage protection

We highly recommend to install the RESOL overvoltage protection in order to avoid overvoltage damages at the collector (e.g. by lightning).



Flowmeter

If you are interested in realising a heat quantity balancing, you need a flowmeter for measuring the volume flow in your system.



RESOL - Elektronische Regelungen GmbH

Heiskampstraße 10
D - 45527 Hattingen

Tel.: +49 (0) 23 24 / 96 48 - 0
Fax: +49 (0) 23 24 / 96 48 - 755

www.resol.de
info@resol.de

Distributed by:

Please note:

The design and the specifications are to be changed without notice.
The illustrations may differ from original product.