

# RESOL ER3

**Mounting**

**Connection**

**Handling**

**Fault localization**

**Examples**



48002770

Thanks for buying this RESOL-product.  
Read this manual carefully to get the best performance from this unit.

# ER3



manual

[www.resol.de](http://www.resol.de)

**Security advice**

Please pay attention to the following security advice in order to avoid danger and damage to people and property.

**Instructions**

Attention should be paid

- to the statutory provisions for prevention of industrial accidents,
- to the statutory provisions for environmental protection,
- to the Health and Safety at Work Act 1974
- to Part P of the Building Regulations 2005
- to BS7671 Requirements for electrical installations and relevant safety regulations of DIN, EN, DVGW, TRGI, TRF and VDE.

This instruction is exclusively addressed to authorised skilled personnel.

- Only qualified electricians should carry out electrical works.
- Initial installation should be effected by named qualified personnel

**Contents**

<b>Security devices</b> .....	<b>2</b>
<b>Technical data and function survey</b> .....	<b>3</b>
<b>1. Installation</b> .....	<b>4</b>
1.1 Mounting.....	4
1.2 Electrical wiring.....	5
1.3 Data communication / Bus .....	5
1.2.1 Standard solar system.....	6
1.2.2 Solar system and after-heating.....	6
<b>2. Operation and function</b> .....	<b>7</b>
2.1 Adjustment buttons .....	7
2.2 System monitoring display .....	7
2.2.1 Channel indication.....	7
2.2.2 Tool bar .....	7
2.2.3 System screen.....	8
2.3 Blinkcodes.....	8
2.3.1 System-Screen Blinkcodes .....	8
2.3.2 Blinking codes.....	8
<b>3. Commissioning</b> .....	<b>9</b>
<b>4. Control parameter and indication channels</b> .....	<b>10</b>
4.1 Channel overview.....	10
4.1.1-6 Indication channels .....	11
4.1.7-19 Adjustment channels.....	12
<b>5. Tips for fault localization</b> .....	<b>17</b>
5.1 Miscellaneous.....	18
<b>6. Accessory</b> .....	<b>20</b>
<b>Imprint</b> .....	<b>20</b>

**Declaration of conformity**

We, RESOL Elektronische Regelungen GmbH, D-45527 Hattingen, declare under our sole responsibility that our product ER3 complies with the following standards:

EN 55 014-1

EN 60 730-1

According to the regulations of the above directives, the product is labelled with **CE**:

89/336/EWG

73/ 23/EWG

Hattingen, 07.07.2006

RESOL Elektronische Regelungen GmbH,

ppa. 

ppa. Gerald Neuse

- system-monitoring-display
- up to 4 temperature sensors Pt1000
- heat balancing
- function control
- VBus®
- user-friendly operation by simple handling
- solar operating hours counter and thermostat function optionally

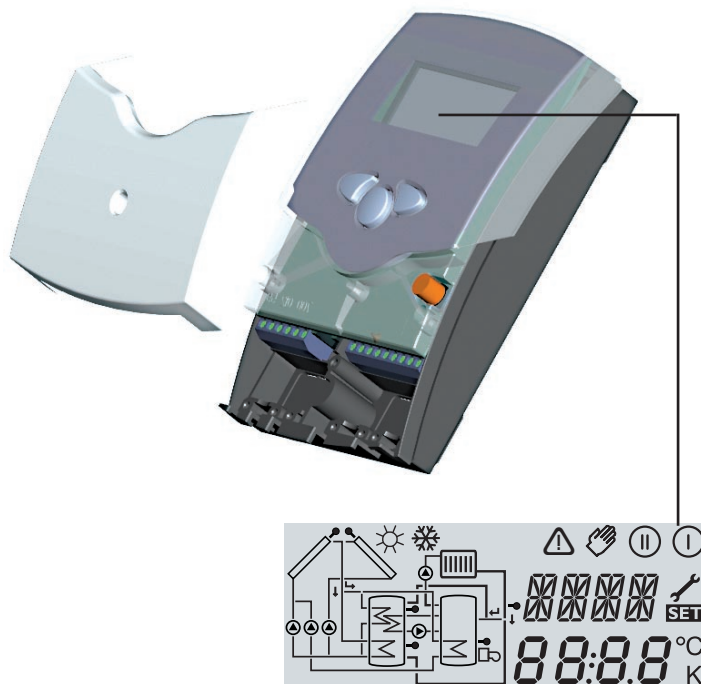

#### Scope of delivery:

1 x ER3

1 x accessory bag

1 x spare fuse T4A

2 x screws and dowels

4 x strain relief and screws

Additionally enclosed in the full kit:

1 x sensor FKP9

2 x sensor FRP6

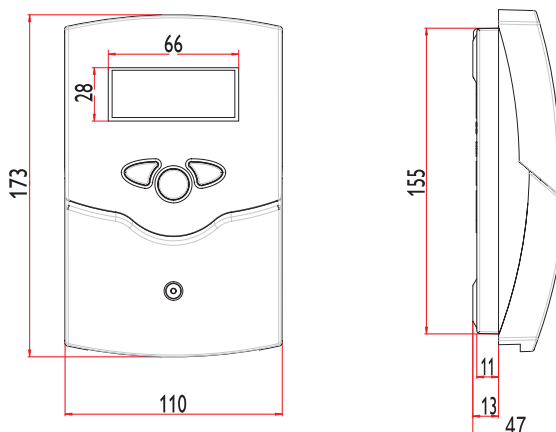

#### Technical data

##### Housing:

plastic, PC-ABS and PMMA

**Protection type:** IP 20 / DIN 40050

**Environmental temp.:** 0 ... 40 °C

**Size:** 172 x 110 x 46 mm

**Mounting:** wall mounting, mounting into patch-panels is possible

**Display:** System screen for systems visualisation, 16-segment display, 7-segment display, 8 symbols for system status and operating control lamp

**Operation:** by 3 pushbuttons in the front of the housing

**Functions:** Temperature differential controller with optional add-on system functions. Function control according to BAW-guidelines, operating hours counter for solar pump, tube collector special function, as well as heat quantity balancing.

**Inputs:** for 4 temperature sensors Pt1000

**Outputs:** 2 standard relays

**Bus:** VBus® (version 67.30)

##### Power supply:

220 ... 240 V~

##### Mode of operation:

Typ 1.b

##### Breaking capacity per relay:

electromechanical relay:

2 (1) A (220 ... 240) V~



## Examples ER3

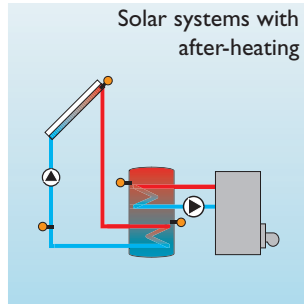
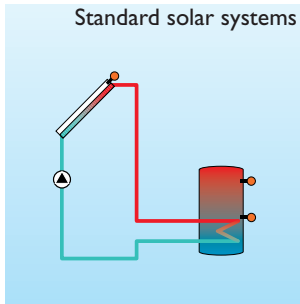

Please find detailed connection schemes for the shown systems in chapter 1.

## 1. Installation

### 1.1 Mounting

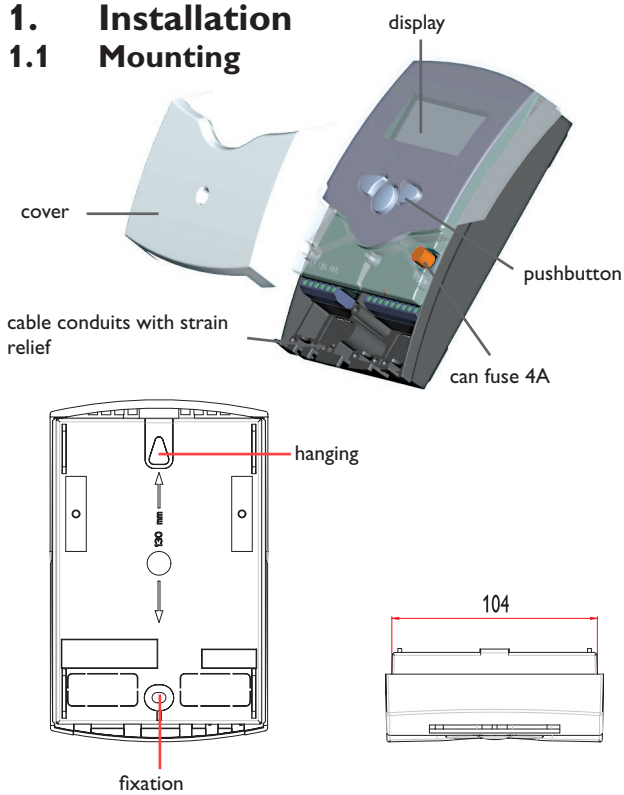

**Warning!**  
Switch-off power supply before opening the housing.

The unit must only be located internally. It is not suitable for installation in hazardous locations and should not be sited near to any electromagnetic field. The controller must additionally be equipped with an all-polar gap of at least 3 mm or with a gap according to the valid installation regulations, e.g. LS-switches or fuses. Please pay attention to a separate laying of the cable lines and installation of ac power supply.

1. Unscrew the cross-recessed screw of the cover and remove it from the housing.
2. Mark the upper fastening point on the wall and pre-mount the enclosed dowel and screw.
3. Hang up the housing at the upper fastening point and mark the lower fastening point on the underground (hole distance 130 mm), afterwards put the lower dowel.
4. Fasten the housing at the underground.

## 1.2 Electrical connection

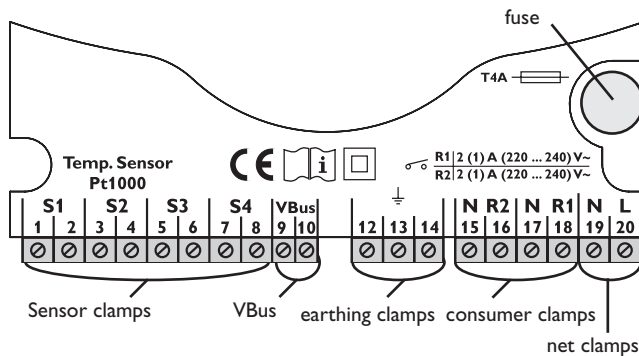

The power supply to the controller must only be made by an external power supply switch (last step of installation!) and the line voltage must be 220 ... 240 Volt (50...60 Hz). Flexible lines have to be fixed at the housing by enclosed strain relief supports and screws.

Depending on the version the controller is equipped with 2 relays to which the **consumers** e.g. pumps, valves etc. can be connected:

- Relay 1
  - 18 = conductor R1
  - 17 = neutral conductor N
  - 13 = ground clamp ⊕
- Relay 2
  - 16 = conductor R2
  - 15 = neutral conductor N
  - 14 = ground clamp ⊕

The **temperature sensors** (S1 up to S4) will be connected to the following terminals independently of the polarity:

- 1 / 2 = Sensor 1 (e.g. Sensor collector 1)
- 3 / 4 = Sensor 2 (e.g. Sensor store 1)
- 5 / 6 = Sensor 3 (e.g. Sensor TSPO)
- 7 / 8 = Sensor 4 (e.g. Sensor TRL)

The **power supply** is effected to the clamps:

- 19 = neutral conductor N
- 20 = conductor L
- 12 = ground clamp ⊕



Electrostatic discharge can lead to damages of electronic components!



Dangerous voltage on contact!

## 1.3 Data communication/ Bus

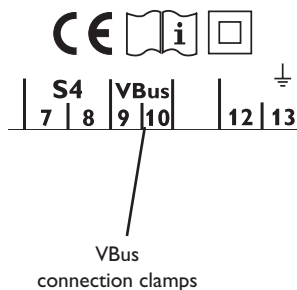

The controller comes with a VBus® for data communication and energy supply of external modules. The connection is effected with optional polarity at the clamps marked with „VBus“. Via this data Bus you can install one or more VBus® modules, e.g.:

- heat quant. measurement module WMZ-M1
- large display GA3
- Data logger, DL1
- Data teleindication, DFA2

Additionally, the controller can be connected to the PC with the help of a RS-COM adapter. With the **Service Center Software** the controller parameters can be changed, measurements can be read out, processed and visualised. The software enables an easy function control and adjustment of the system. A light Version of the software can be downloaded from [www.resol.de](http://www.resol.de) for free.

1.2.1 Allocation of clamps for system 1

Standard solar system with 1 store, 1 pump and 3 sensors. The sensor S4 / TRF can optionally be used for heat quantity balancing.

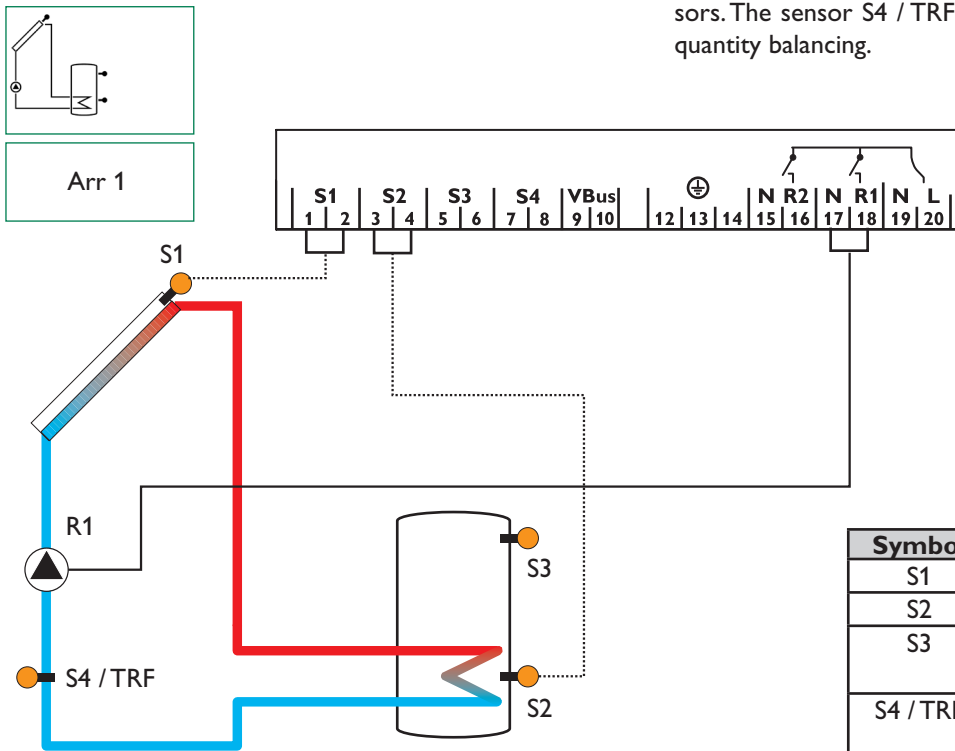

Symbol	Specification
S1	Collector sensor
S2	Store sensor below
S3	Store sensor at the top (optionally)
S4 / TRF	Sensor for heat quantity measurement (optionally)
R1	Solar pump

1.2.2 Allocation of clamps for system 2

Solars system and after-heating with 1 store, 3 sensors and after-heating. The sensor S4 / TRF can optionally be used for heat quantity balancing.

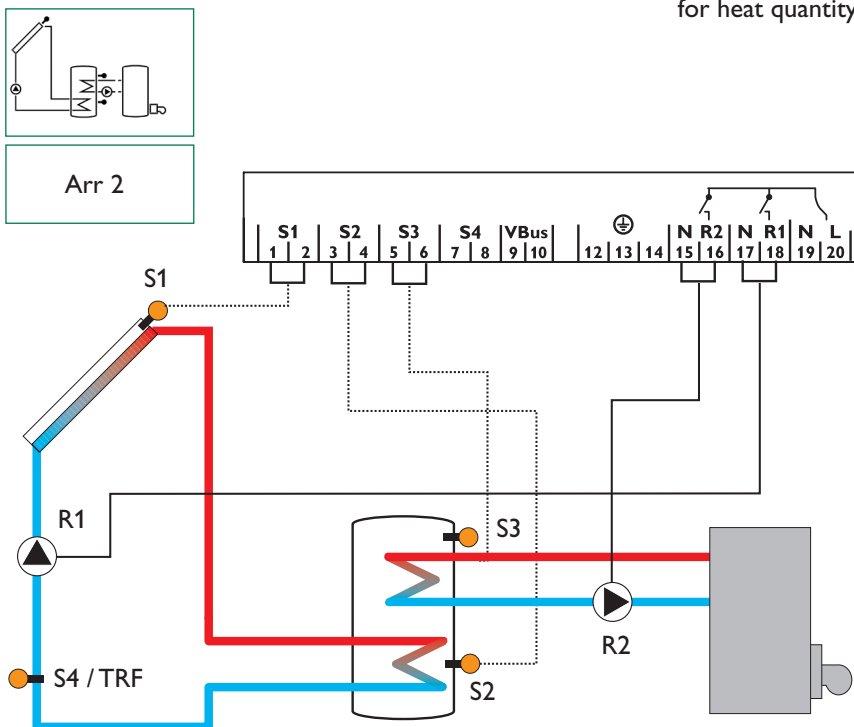

Symbol	Specification
S1	collector sensor
S2	store sensor below
S3	store sensor at the top
S4 / TRF	sensor for heat quantity balancing (optionally)
R1	solar pump
R2	pump for heat exchange

## 2. Operation and function

### 2.1 Pushbuttons for adjustment

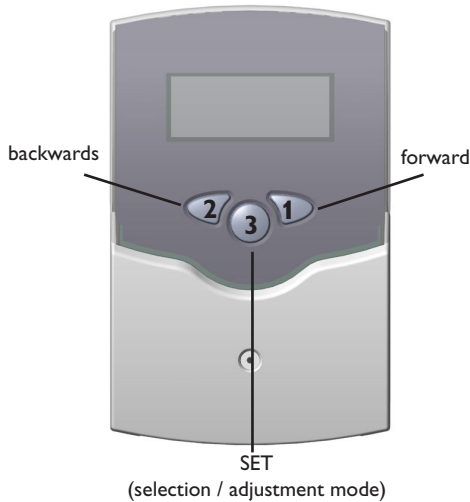

The controller is operated by 3 pushbuttons below the display. The forward-key (1) is used for scrolling forward through the indication menu or to increase the adjustment values. The backwards-key (2) is accordingly used for the reverse function.

For adjustment of last indication channel, keep button 1 pressed for 2 seconds. If an **adjustment value** is shown on the display, **SEt** is indicated. In this case you can press the key „Set“ (3) in order to change into input mode.

Select a channel by keys 1 and 2  
 Shortly press key 3, so that „SEt“ flashes  
 Adjust the value by keys 1 and 2  
 Shortly press key 3, so that „SEt“ permanently appears, the adjusted value is now saved.

### 2.2 System monitoring display

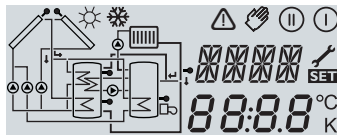

Complete Monitoring-Display

The system monitoring display consists of 3 blocks: **indication of the channel**, **tool bar** and **system screen** (active system scheme).

#### 2.2.1 Channel indication



only channel indication

The **indication channel** consists of two lines. The upper line is an alphanumeric 16-segment indication, in which mainly the channel names / menu items are shown. In the lower 7-segment indication, the channel values and the adjustment parameter are indicated.

Temperatures and temperature differences are indicated in °C or K.

#### 2.2.2 Tool bar



only tool bar

The additional symbols of the **tool bar** indicate the current system status.

Symbol	standard	flashing
ⓘ	relay 1 active	
Ⓜ	relay 2 active	
☀	maximum store limitation active / maximum store temperature exceeded	collector cooling function or recolling function active
❄	antifreeze- function activated	collector minimum limitation or antifreeze function active
⚠		collector security shutdown or store securtiy shutdown active
⚠ + 🔧		sensor defect
⚠ + ✋		manual operation active
SEt		an adjustment channel is changed SET-mode

2.2.3 System screen

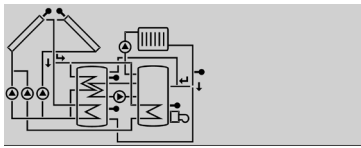

only system screen

The system screen (active system scheme) shows the schemes selected on the controller. It consists of several system component symbols, which are - depending on the current status of the system - either flashing, permanently shown or hidden.

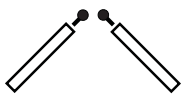
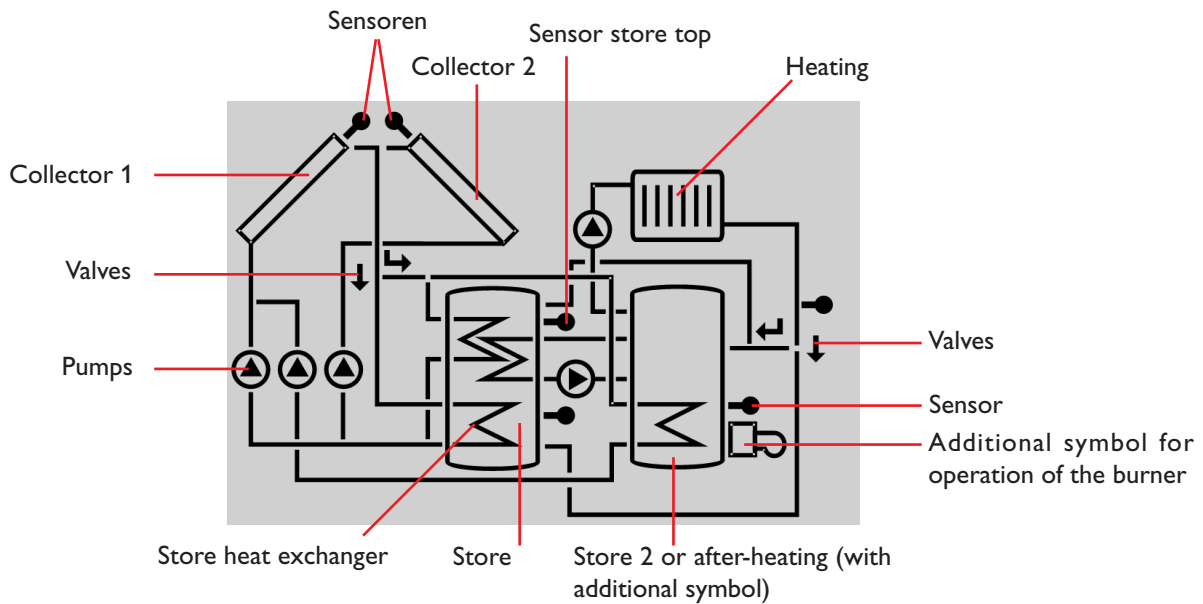

**Collectors**  
with collector sensor

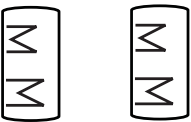

**Store 1 and 2**  
with heat exchanger



**3-way-valves**  
The flow direction or the current breaking capacity are always shown.



**Temperature sensor**



**Heating circuit**



**Pump**

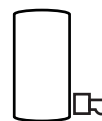

**After-heating**  
with burner symbol

2.3 Blinking codes

2.3.1 System screen blinking codes

- Pumps are blinking during starting phase
- Sensors are blinking if the respective sensor-indication channel is selected.
- Sensors are quickly blinking in case of sensor defect.
- Burner symbol is blinking if after-heating is activated.

2.3.2 LED blinking codes

- Constantly green: everything all right
- Red/green blinking: initialisation phase  
manual operation
- Red blinking: sensor defect  
(sensor symbol is quickly blinking)

### 3. Commissioning

On commissioning you have to adjust primarily the matching system

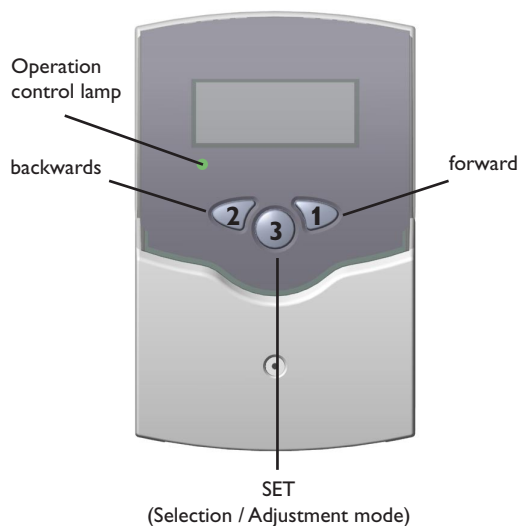

1. AC power supply must be activated. The controller passes an initialisation phase in which the operating control lamp flashes red and green. After having finished the initialisation, the controller is in automatic operation with factory settings. The preadjusted system scheme is Arr 1.

2. - select Arr

- change into **SET**-mode (see 2.1)

- select the system scheme by Arr-characteristics

- adjustment is saved by pressing button **SET**

Now the controller is ready for operation and should enable an optimum operation of the solar system by the factory settings made.

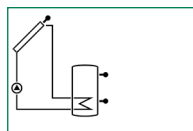

Arr 1

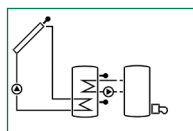

Arr 2

#### System survey:

Arr 1 : standard solar system

Arr 2 : solar system with after-heating

## 4. Controller parameter and indication channels

### 4.1 Channel-overview

#### Legend:

x

Corresponding channel is available.

x\*

Corresponding channel is available if the appropriate option is activated.

①

Corresponding channel is only available if the option heat quantity measurement is **activated** (OHQM).

②

Corresponding channel is only available if the option heat quantity measurement is **deactivated** (OHQM).

MEDT

The channel antifreeze content (MED%) is only shown if a medium other than **water or Tyfocor LS / G-LS (MEDT 0 or 3)** is used. The adjustment is only appropriate when using other types of antifreeze.

#### Please note:

S3 and S4 are only indicated if sensors are connected.

channel	Arr		specification	page
	1	2		
COL	x	x	Temperature collector 1	11
TST	x		Temperature store 1	11
TSTL		x	Temperature store 1 below	11
TSTU		x	Temperature store 1 above	11
S3	x		Temperature sensor 3	11
TRF	①	①	Temperature return sensor	11
S4	②	②	Temperature sensor 4	11
h P	x		Operating hours relay 1	11
h P1		x	Operating hours relay 1	11
h P2		x	Operating hours relay 2	11
kWh	①	①	Heat quantity kWh	12
MWh	①	①	Heat quantity MWh	12
Arr	1-2		System	9
DT O	x	x	Switch-on temperature difference	13
DT F	x	x	Switch-off temperature difference	13
S MX	x	x	Maximum temperature store 1	13
EM	x	x	emergency temperature collector 1	14

channel	Arr		specification	page
	1	2		
OCX	x	x	Option collector cooling collector 1	14
CMX	x*	x*	Maximum temperature collector 1	14
OCN	x	x	Option minimum limitation collector 1	14
CMN	x*	x*	Minimum temperature collector 1	14
OCF	x	x	Option antifreeze collector 1	14
CFR	x*	x*	Antifreeze temperature collector 1	14
OREC	x	x	Option reccoling	15
OTC	x	x	Option tube collector	15
AH O		x	Switch-on temp. for thermostat 1	15
AH F		x	Switch-off temp. for thermostat 1	15
OHQM		x	Option WMZ	12
FMAX	①	①	Maximum flow	12
MEDT	①	①	Antifreeze type	12
MED%	MEDT	MEDT	Antifreeze content	12
HND1	x	x	Manual operation relay 1	16
HND2	x	x	Manual operation relay 2	16
LANG	x	x	Language	16
PROG	XX.XX		Program number	
VERS	X.XX		Version number	

#### 4.1.1 Indication of collector temperatures

##### COL:

Collector temperature  
display range: -40...+250 °C



Shows the current collector temperature.

- COL : collector temperature (1-collector-system)

#### 4.1.2 Indication of store temperatures

##### TST,TSTL,TSTU:

Store temperatures  
Display range: -40...+250 °C

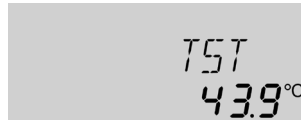

Shows the current store temperature.

- TST : store temperature (1-store-system)
- TSTL : store temperature lower
- TSTU : store temperature upper

#### 4.1.3 Indication of sensor 3 and sensor 4

##### S3, S4:

Sensor temperatures  
Display range: -40...+250 °C

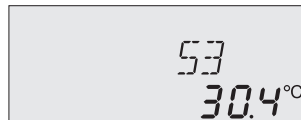

Shows the current temperature of the corresponding additional sensor (without control function).

- S3 : temperature sensor 3
- S4 : temperature sensor 4

##### Please note:

S3 and S4 are only indicated if the temperature sensors are connected (shown).

#### 4.1.4 Indication of other temperatures

##### TRF:

other measured  
temperatures  
Display range: -40...+250 °C



Shows the current temperature of the sensor.

- TRF : temperature return flow

#### 4.1.5 Operating hours counter

##### h P / h P1 / h P2:

Operating hours counter  
Display channel

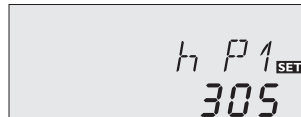

The operating hours counter adds up the solar operating hours of the respective relay (**h P / h P1 / h P2**). Full hours are shown on the display.

The operating hours added up can be reset. As soon as one operating hours channel is selected, the symbol **SET** is permanently shown on the display. The button SET (3) must be pressed for approx. 2 seconds in order to get back into the RESET-mode of the counter. The display-symbol **SET** is flashing and the operating hours will be set to 0. In order to finish the RESET-procedure, the button **SET** must be pressed in order to confirm.

In order to interrupt the RESET-procedure, no button should be pressed for about 5 seconds. The controller returns automatically into the indicator mode.

#### 4.1.6 Heat quantity balancing

**OHQM:**Heat quantity balancing

Adjustment range: OFF...ON

Factory setting: OFF



**FMAX:**

Volume flow in l/min

Adjustment range 0... 20

in steps of 0,1

Factory setting 6,0

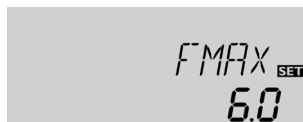

**MEDT:** Type of antifreeze

Adjustment range 0...3

Factory setting 1

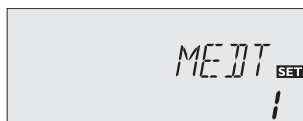

**MED%:** Concentration of antifreeze in (Vol-) %

MED% is blinded out by

MEDT 0 and 3.

Adjustment range 20...70

Factory setting 45



**kWh/MWh:**Heat quantity

in kWh / MWh

Display channel



A heat quantity balancing is possible for all systems in conjunction with a flowmeter. You just have to activate the option heat quantity balancing in the channel **OHQM**.

The volume flow readable at the flowmeter (l/min) must be adjusted in the channel **FMAX**. Antifreeze type and concentration of the heat transfer medium are indicated on the channels **MEDT** and **MED%**.

#### Type of antifreeze:

0 : water

1 : propylene glycol

2 : ethylene glycol

3 : Tyfocor® LS / G-LS

The heat quantity transported is measured by the indication of the volume flow and the reference sensor of feed flow S1 and return flow S4. It is shown in kWh-parts in the indication channel **kWh** and in MWh-parts in the indication channel **MWh**. The sum of both channels form the total heat output.

The heat quantity added up can be reset. As soon as one of the display channels of the heat quantity is selected, the symbol **SET** is permanently shown on the display. The button SET (3) must be pressed for approx. 2 seconds in order to get back into the RESET-mode of the counter. The display-symbol **SET** is flashing and the value for heat quantity will be set to 0. In order to finish the RESET-procedure, the button **SET** must be pressed for confirmation.

In order to interrupt the RESET-procedure, no button should be pressed for about 5 seconds. The controller returns automatically into indication mode.

#### 4.1.7 $\Delta T$ -regulation

##### DT O:

Switch-on temperature  
Adjustment range 1,0...20,0 K  
Factory setting 6.0



##### DT F:

Switch-off temperature diff.  
Adjustment range  
0,5 ... 19,5 K  
Factory setting 4.0 K

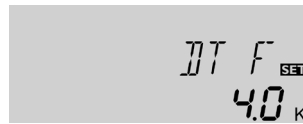

Primarily the controller works in the same way as a standard differential controller. If the switch-on difference (**DT O**) is reached, the pump is activated and after having got an impulse (10 s) a minimum pump speed (nMN = 30 %) is run. The response of the controller can be adapted by means of the parameter „Raise“. If the adjusted switch-off temperature is underrun (**DT F**), the controller switches-off.

**Please note:** Switch-on temperature difference DO must be at least 1 K higher than the switch-off temperature-difference DF.

#### 4.1.8 Maximum store temperature

##### S MX:

Maximum store temp.  
Adjustment range 2..95 °C  
Factory setting 60 °C

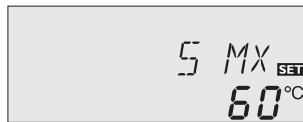

If the adjusted maximum temperature is exceeded, a further loading of the store is stopped so that a damaging overheating can be avoided. If the maximum store temperature is exceeded, on the display ☀ is shown.

**Please note:** The controller is equipped with a security-switch-off of the store, which avoids a further loading of the store if 95 °C are reached at the store.

#### 4.1.9 Limit collector temperature Collector emergency shutdown

##### EM:

Limit collector temperature  
Adjustment range  
110 ... 200 °C,  
Factory setting 140 °C



If the adjusted collector limit temperature (**EM**) is exceeded, the solar pump (R1/R2) is deactivated in order to avoid a damaging overheating of the solar components (collector emergency shutdown). The limit temperature is set to 140 °C but it can be changed within the adjustment range of 110...200 °C. In the display is shown  $\Delta$  (flashing).

#### 4.1.10 System cooling

##### OCX:

Option system cooling  
Adjustment OFF ... ON  
Factory setting OFF



##### CMX:

Maximum collector temp.  
Adjustment range  
100...190 °C  
Factory setting 120 °C



If the adjusted maximum store temperature is reached, the solar system switches-off. If now the collector temperature raises to the adjusted maximum collector temperature (**CMX**), the solar pump remains activated until this limit temperature value is again underrun. The store temperature might continue to raise (subordinated active maximum store temperature), but only until 95 °C (emergency shutdown of the store). If the store temperature is higher than the maximum store temperature (**SMX**) and the collector temperature is lower by at least 5 K than the store temperature, the solar system remains activated until the store is again cooled down by the collector and the tubes under the adjusted maximum temperature (**SMX**).

In case of active system cooling on the display is shown  $\star$  (flashing). Due to the cooling function the solar system can be kept operable for a longer period on hot summer days and a thermal release of the collector and the heat transfer medium is ensured as well.

#### 4.1.11 Option minimum collector limitation

##### OCN:

Minimum collector limitation  
Adjustment range OFF / ON  
Factory setting OFF



##### CMN:

Minimum collector temperature  
Adjustment range  
-10 ... 90 °C  
Factory setting 10 °C

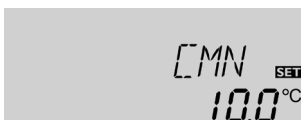

The minimum collector temperature is a minimum switching temperature, which must be exceeded so that the solar pump (R1/R2) is switched-on. The minimum temperature shall avoid a steady starting-up of the solar pump (or solid fuel boiler charging pumps) for low collector temperatures. If the minimum temperature is underrun, in the display is shown  $\star$  (flashing).

#### 4.1.12 Option antifreeze function

##### OCF:

Antifreeze function  
Adjustment range  
OFF / ON  
Factory setting OFF



##### CFR:

Antifreeze temperature  
Adjustment range  
-10 ... 10 °C  
Factory setting 4,0 °C



The antifreeze function activates the loading circuit between collector and store if the adjusted antifreeze function is underrun in order to protect the medium that it will not freeze or „get thick“. If the adjusted antifreeze temperature is exceeded by 1 °C, the loading circuit will be deactivated.

Please note:

As there is only a limited heat quantity of the store available for this function, the antifreeze function should only be used in regions with few days of temperatures around freezing point.

#### 4.1.13 Recooling function

##### OREC:

option recooling  
adjustment range  
OFF...ON  
Factory setting: OFF



If the adjusted maximum store temperature (**S MX**) is reached, the solar pump remains activated in order to avoid an overheating of the collector. The store temperature might continue to increase but only up to 95 °C (emergency shutdown of the store).

In the evening the solar system continues running until the store is cooled down to the adjusted maximum store temperature via collector and pipes.

#### 4.1.14 Tube collector special function

##### OTC:

Tube collector special  
function  
Adjustment range:  
OFF...ON  
Factory setting: OFF



If the controller measures an increase of 2 K compared to the collector temperature stored at last, the solar pump is switched-on to 100 % for about 30 seconds. After expiration of the solar pump runtime the current collector temperature is stored as new reference value. If the measured temperature (new reference value) is again exceeded by 2 K, the solar pump again switches-on for 30 seconds. If the switch-on difference between collector and store is again exceeded during runtime of the solar pump or the standstill of the system, the controller automatically switches over to solar charging.

If the collector temperature drops by 2 K during standstill, the switch-on value for the special tube collector function will be recalculated.

#### 4.1.17 Thermostat function (Arr = 2)

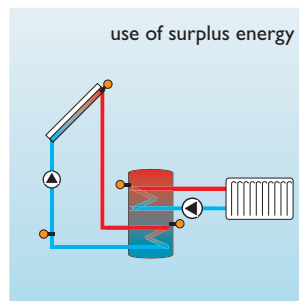
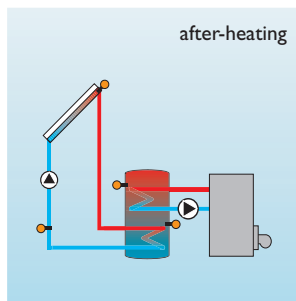

The thermostat function works independently from the solar operation and can e.g. be used for use of surplus energy or an after-heating.

- **AH O < AH F**  
the thermostat function is used for after-heating
- **AH O > AH F**  
the thermostat function is used for use of surplus energy



##### AH O:

Thermostat-switch-on  
temperature  
Adjustment range:  
0,0...95,0 °C  
Factory setting: 40,0 °C



##### AH F:

Thermostat-switch-off tem-  
perature  
Adjustment range:  
0,0...95,0 °C  
Factory setting: 45,0 °C

On the display is shown  if the second relay output is activated.

#### 4.1.18 Operating mode

##### HND1 / HND2:

Operating mode

Adjustment range:

OFF,AUTO, ON

Factory setting:AUTO



For control and service work the operating mode of the controller can be manually adjusted by selecting the adjustment value HND1 / HND2, in which the following adjustments can be made:

##### • HND1 / HND2

Operating mode

OFF : relay off ⚠ (flashing) + 🖱

AUTO : relay in automatic operation

ON : relay on ⚠ (flashing) + 🖱

The relay will switch back from ON to AUTO after 5 minutes.

#### 4.1.19 Language

##### LANG:

Adjustment of language

Adjustment range:

dE, En, It, Fr

Factory setting: En



The menu language can be adjusted in this channel.

- dE : German
- En : English
- It : Italiano
- Fr : French

### 5. Tips for fault localization

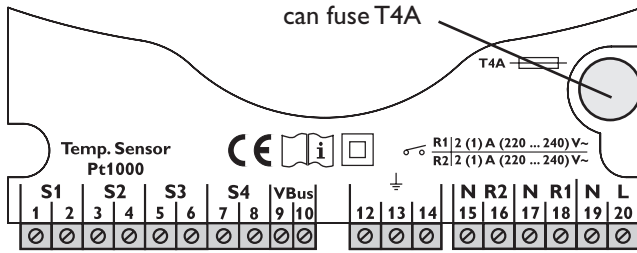

If a malfunction occurs, a notification is given on the display of the controller:

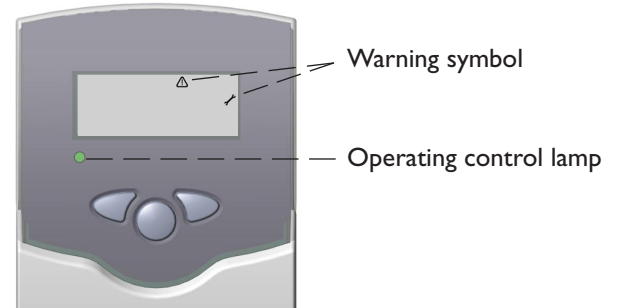

Operating control lamp flashes red. On the display appears the symbol and the symbol .

Operating control lamp off

Sensor defect. An error code is shown on the relevant sensor indication channel instead of a temperature.

888.8

- 88.8

Line break. Check the line.

Short-circuit. Check the line.

Check the power supply

o.k.

The can fuse of the controller is defective. It can be replaced after removal of the front cover (spare fuse is enclosed in the accessory bag).

Pt1000-temperature sensors pinched off can be checked with an ohmmeter. In the following the resistance values corresponding to different temperatures are listed.

°C	Ω	°C	Ω
-10	961	55	1213
-5	980	60	1232
0	1000	65	1252
5	1019	70	1271
10	1039	75	1290
15	1058	80	1309
20	1078	85	1328
25	1097	90	1347
30	1117	95	1366
35	1136	100	1385
40	1155	105	1404
45	1175	110	1423
50	1194	115	1442

Resistance values of the Pt1000-sensors

5.1 Various:

Pump is overheated, but no heat transfer from collector to the store, feed flow and return flow are equally warm, possibly also bubble in the tubes

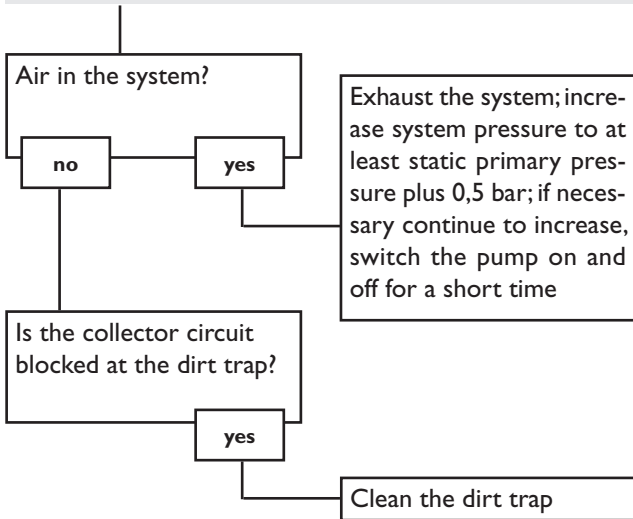

Pump starts for a short moment, switches-on/off repeatedly

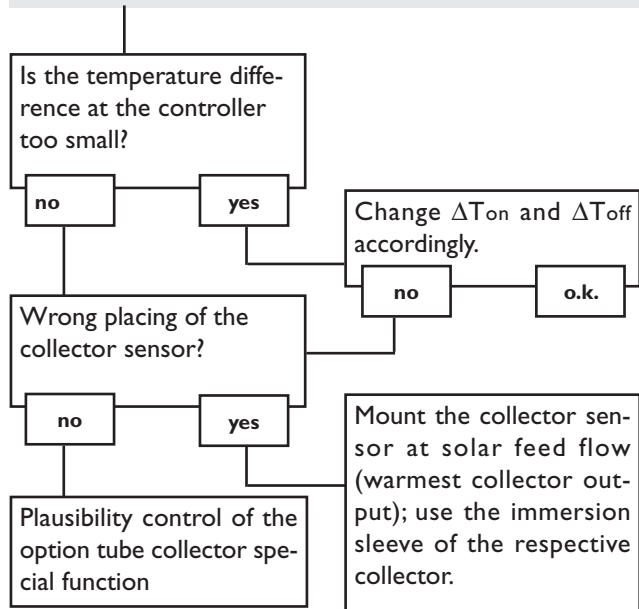

Pump starts up very late and stops working soon.

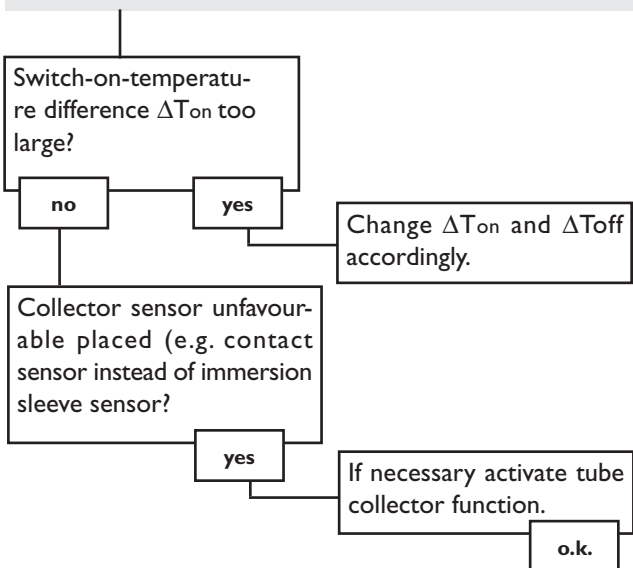

The temperature difference between store and collector increases enormously during operation; the collector circuit cannot dissipate the heat.

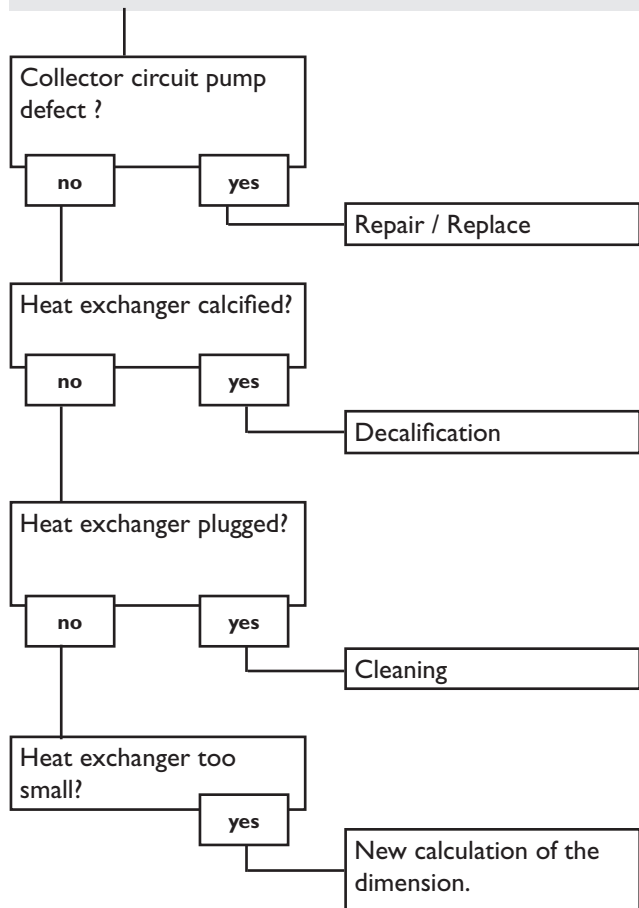

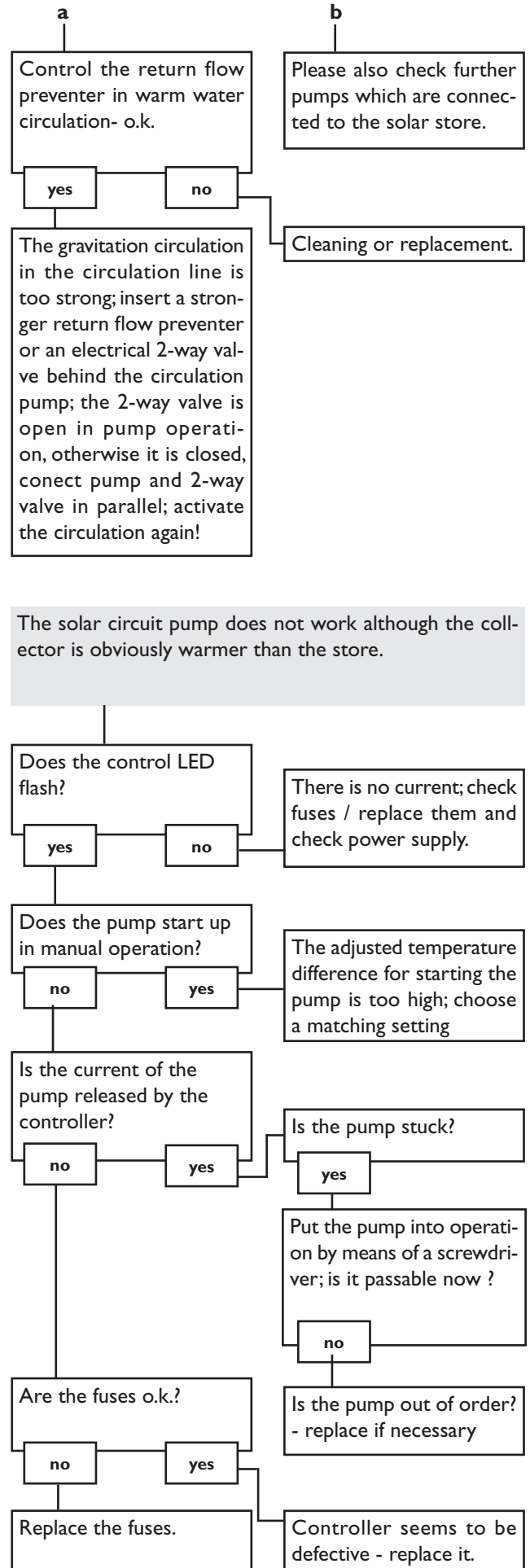
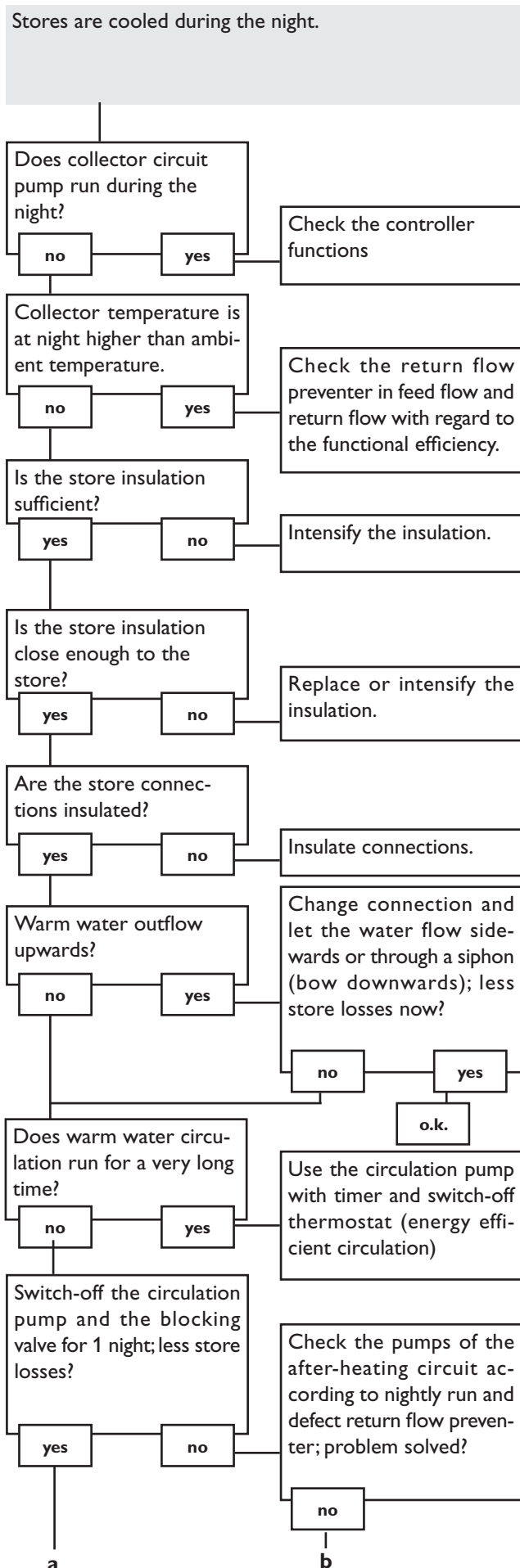

## 6. Accessory

### Sensors

Our product range includes high-precision platinum temperature sensors, flatscrew sensors, ambient temperature sensors, indoor temperature sensors, cylindrical clip-on sensors and irradiation sensors, also to be used as full sensors with sensor pocket.



### Overvoltage protection

We highly recommend to install the overvoltage protection in order to avoid overvoltage damages at the collector (e.g. by lightning).



### Flowmeter

If you are interested in realising a heat quantity balancing, you need a flowmeter for measuring the volume flow in your system.



### Distributed by:

#### RESOL - Elektronische Regelungen GmbH

Heiskampstraße 10  
45527 Hattingen / Germany  
Tel.: +49 (0) 23 24 / 96 48 - 0  
Fax: +49 (0) 23 24 / 96 48 - 755  
[www.resol.de](http://www.resol.de)  
[info@resol.de](mailto:info@resol.de)

### Reprinting / copying

This mounting- and operation manual including all parts is copyrighted. Another use outside the copyright requires the approval of RESOL - Elektronische Regelungen GmbH. This especially applies for copies, translations, micro films and the storage into electronic systems. Editor: RESOL - Elektronische Regelungen GmbH

### Important notice:

We took a lot of care over the texts and drawings of this manual and to the best of our knowledge and consent. As faults can never be excluded, please note: Your own calculations and plans under consideration of the current norms and DIN-directions should only be basis for your projects. We don't offer a guarantee for the completeness of the drawings and texts of this manual - they only represent some examples. They can only be used on own risk. No liability is assumed for incorrect, incomplete or false information and the resulting damages.

Errors and technical changes excepted.

### Please note:

The design and the specifications are to be changed without notice. The illustrations may differ from original product.