

# DeltaSol® ES

## Examples of use

System description

Connection schemes

Adjustment



# DeltaSol® ES

en

System  
description



11202135

Thank you for buying this product.  
Please read this document carefully, to get the best performance from this unit.

## Overview of systems

The controller is pre-programmed for 36 basic systems. For these systems and hydraulic variants, the relay and sensor

allocation has to be carried out as followed. For information on the use of a calorimeter, see page 116.

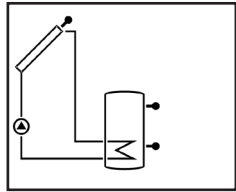

system 1 (p. 4)

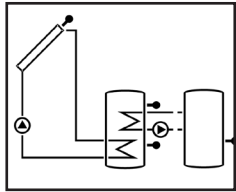

system 2 (p. 6)

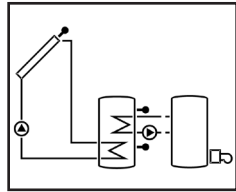

system 3 (p. 9)

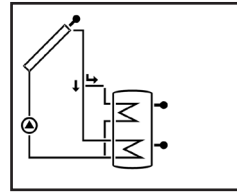

system 4 (p. 12)

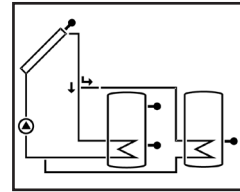

system 5 (p. 15)

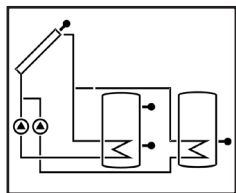

system 6 (p. 18)

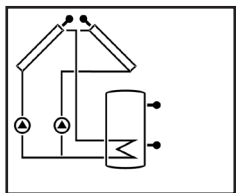

system 7 (p. 21)

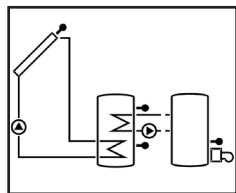

system 8 (p. 24)

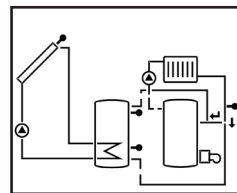

system 9 (p. 27)

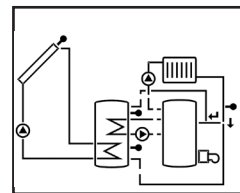

system 10 (p. 30)

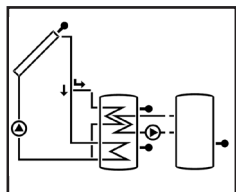

system 11 (p. 32)

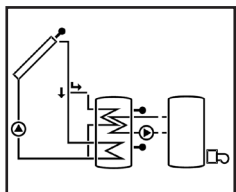

system 12 (p. 35)

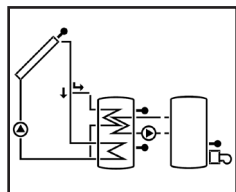

system 13 (p. 38)

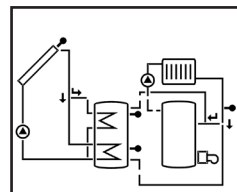

system 14 (p. 41)

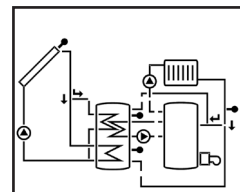

system 15 (p. 44)

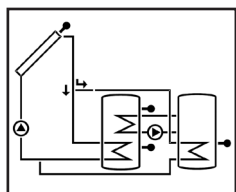

system 16 (p. 47)

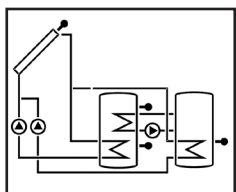

system 17 (p. 50)

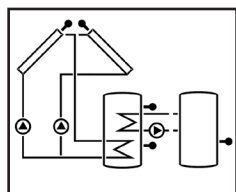

system 18 (p. 53)

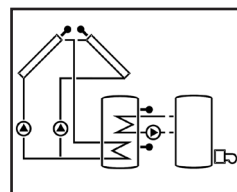

system 19 (p. 56)

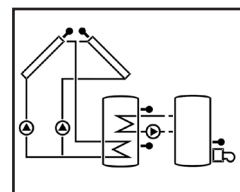

system 20 (p. 59)

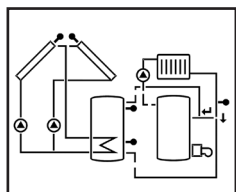

system 21 (p. 62)

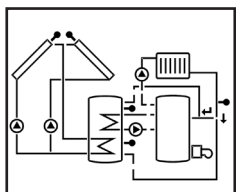

system 22 (p. 65)

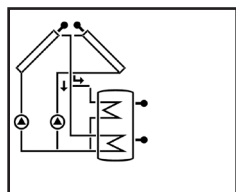

system 23 (p. 68)

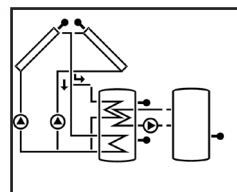

system 24 (p. 71)

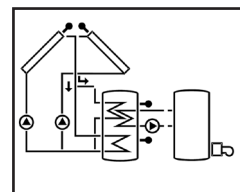

system 25 (p. 75)

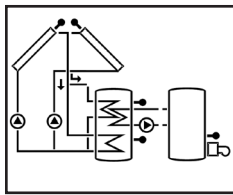

system 26 (p. 78)

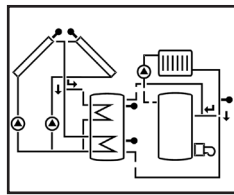

system 27 (p. 82)

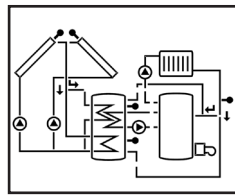

system 28 (p. 85)

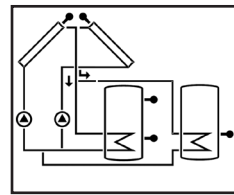

system 29 (p. 89)

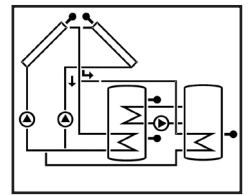

system 30 (p. 92)

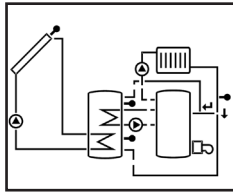

system 31 (p. 96)

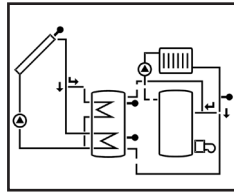

system 32 (p. 99)

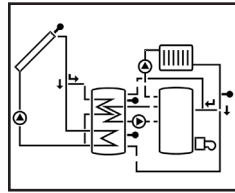

system 33 (p. 102)

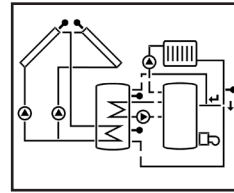

system 34 (p. 106)

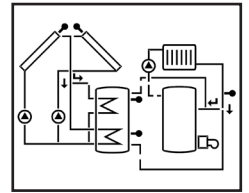

system 35 (p. 109)

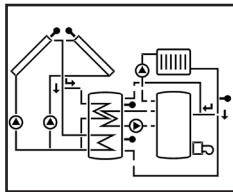

system 36 (p. 113)

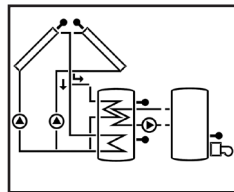

system WMZ (p. 116)

(heat quantity measurement is possible in all systems)

Information on priority logic can be found on page 115.

### Important notice:

The texts and drawings in this manual are correct to the best of our knowledge. As faults can never be excluded, please note: Your own calculations and plans, under consideration of the current standards and directions should only be basis for your projects. We do not offer a guarantee for the completeness of the drawings and texts of this manual - they only represent some examples. They can only be used at your own risk. No liability is assumed for incorrect, incomplete or false information and / or the resulting damages.

Subject to technical changes. Errors excepted.

## System Arrangement 1

### System description:

The controller calculates the temperature difference between collector sensor S1 and store sensor S2. If the difference is larger than or identical to the adjusted switch-on temperature difference, pump P1 will be switched on and

the store will be loaded until the switch-off temperature difference or the maximum store temperature is reached. Sensor S3 can optionally be connected for measurement purposes.

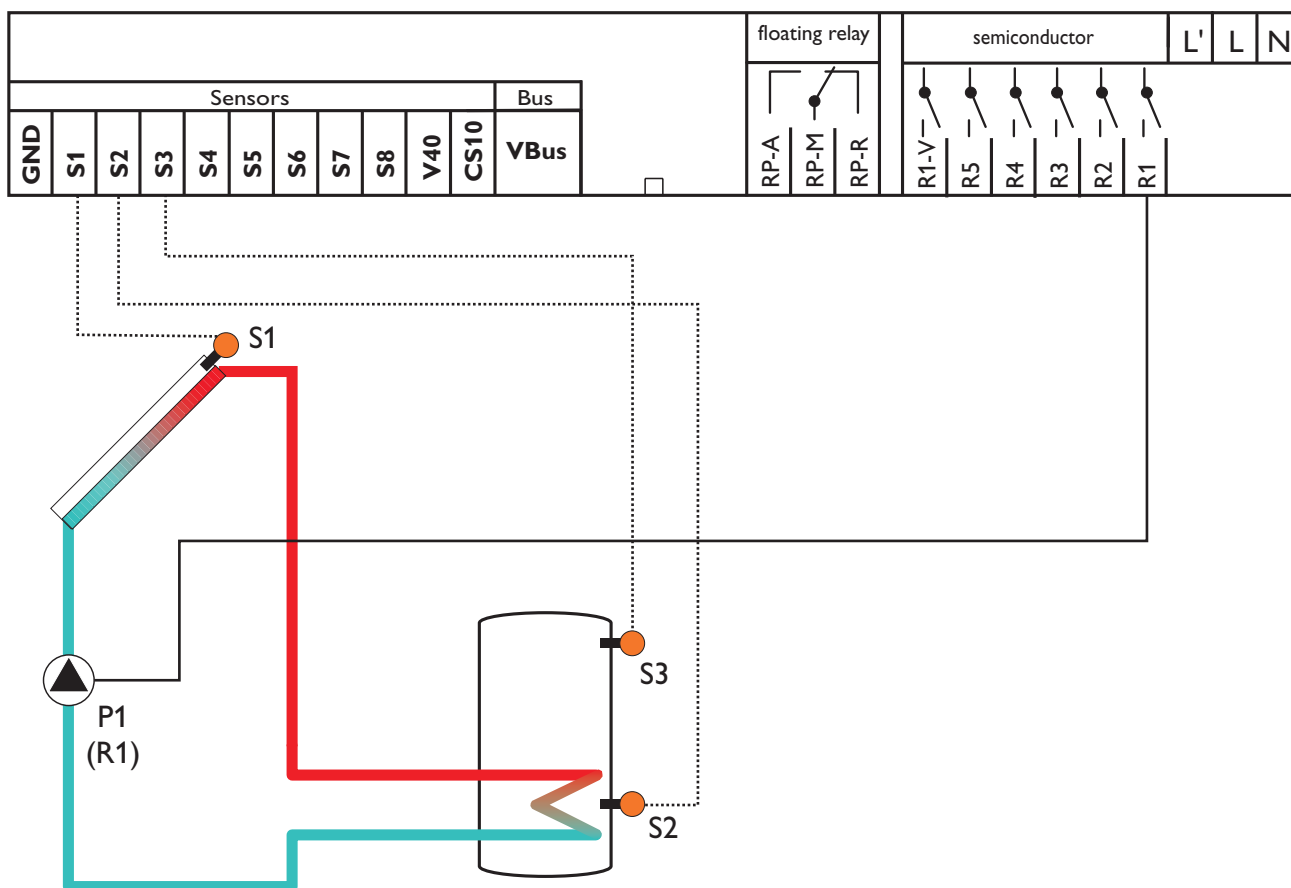

Relay output	Note
R1	solar pump (P1) with speed control
R2	
R3	
R4	
R5	
RP-R	
RP-M	
RP-A	

Sensor input	description
S1	temperature collector
S2	temperature store base
S3	temperature store top (sensor)
CS10 (optional)	irradiation

channel	description	factory setting	change to	note
COL	temperature collector	-----		
TSTB	temperature store 1 base	-----		
TSTU	temperature store 1 top	-----		
IRR	irradiation	-----		
n %	speed relay	-----		
h P	operating hours solar pump	-----		
TIME	time	-----		Adjust the actual clock time.
Arr	arrangement choice	1		Arrangement 1: 1-store system
DT O	switch-on temperature difference	6,0 K		Adjust the desired switch-on temperature difference
DT F	switch-off temperature difference	4,0 K		Adjust the desired switch-off temperature difference
DT S	set temperature difference	10,0 K		Adjust the desired set temperature difference
RIS	rise	2 K		If the adjusted temperature difference DTS is reached and if the temperature increases by the difference RIS, the speed will be increased by 10% respectively.
S MX	maximum store temperature	60 °C		Adjust the desired maximum store temperature
EM	collector emergency temperature	140 °C		Adjust this value to 200°C when the collector emergency shutdown function should not start.
OCX	Option collector cooling	OFF		
OCN	Option minimum limitation	OFF		
OCF	Option frost protection	OFF		
OREC	option recooling	OFF		
OTC	option tube collector	OFF		
OHQM	option heat quantity measurement	OFF		
CS 10	solar irradiation sensor	5		
n MN	minimum speed relay 1	30		
HND1	manual operation relay 1	AUTO		
HND2	manual operation relay 2	AUTO		
HND3	manual operation relay 3	AUTO		
HND4	manual operation relay 4	AUTO		
HND5	manual operation relay 5	AUTO		
HND6	manual operation relay 6	AUTO		
LANG	language	dE		dE = German En = English It = Italian Fr = French
PROG	program number	xx.xx		
VERS	version number	x.xx		

## System Arrangement 2

### System description:

The controller calculates the temperature difference between collector sensor S1 and store sensor S2. If the difference is larger than or identical to the adjusted switch-on temperature difference, pump P1 will be switched on and the store will be loaded until the switch-off temperature difference or the maximum store temperature is reached.

Heat transfer control to an existant store (P2) can be carried out via another temperature differential function (S3/S4).

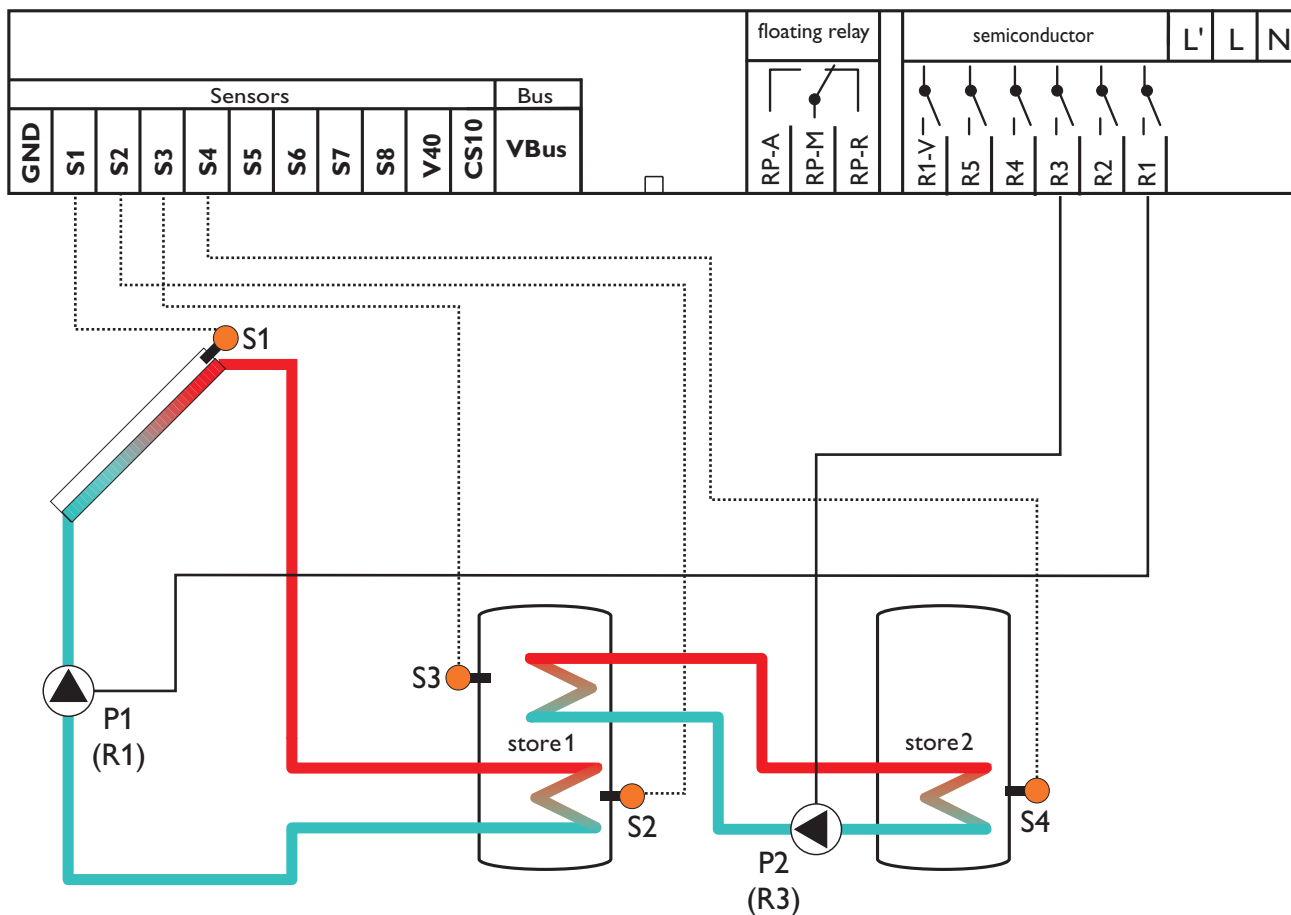

Relay output	Note
R1	solar pump (P1) with speed control
R2	
R3	pump heat exchange (P2)
R4	
R5	
RP-R	
RP-M	
RP-A	

Sensor input	description
S1	temperature collector
S2	temperature store 1 base
S3	temperature store 1 top
S4	temperature store 2 base
CS10 (optional)	irradiation

channel	description	factory setting	change to	note
COL	temperature collector	-----		
TST1	temperature store 1 base	-----		
TSTU	temperature store 1 top	-----		
TST2	temperature store 2 base	-----		
IRR	irradiation	-----		
n1 %	speed relay 1	-----		
n3 %	speed relay 2	-----		
h P1	operating hours relay 1	-----		
h P3	operating hours relay 3	-----		
TIME	time	-----		Adjust the actual clock time.
Arr	arrangement choice	1	2	Arrangement 2: 1-store solar system with heat transfer to existant store
DT O	switch-on temperature difference	6,0 K		Adjust the desired switch-on temperature difference
DT F	switch-off temperature difference	4,0 K		Adjust the desired switch-off temperature difference
DT S	set temperature difference	10,0 K		Adjust the desired set temperature difference
RIS	rise	2 K		If the adjusted temperature difference DTS is reached and if the temperature increases by the difference RIS, the speed will be increased by 10% respectively.
S MX	maximum store temperature	60 °C		Adjust the desired maximum store temperature
EM	collector emergeny temperature	140 °C		Adjust this value to 200°C when the collector emergeny shutdown function should not start.
OCX	Option collector cooling	OFF		
OCN	Option minimum limitation	OFF		
OCF	Option frost protection	OFF		
OREC	option recooling	OFF		
OTC	option tube collector	OFF		
DT3O	switch-on temperature difference 3	6,0 K		Adjust the desired switch-on temperature difference for heat exchange control
DT3F	switch-off temperature difference 3	4,0 K		Adjust the desired switch-off temperature difference for heat exchange control
DT3S	set temperature DT3	10,0 K		Adjust the desired set temperature difference for heat exchange control
RIS3	rise DT3	2 K		If the adjusted temperature difference DT3S is reached and if the temperature increases by the difference RIS3, speed relay 3 (P2) will be increased by 10% respectively.
MX3O	switch-on threshold for maximum temperature	60,0 °C		Adjustment the desired maximum store temperature for the existing store (pump 2) Note: If the maximum store temperature (MX3O) at sensor S4 is reached, pump P2 is switched off. If the store temperature falls below MX3F at S4, the pump is switched-on again.

channel	description	factory setting	change to	note
<b>MX3F</b>	switch-off threshold for maximum temperature	<b>58.0 °C</b>		
<b>MN3O</b>	switch-on threshold for minimum temperature	<b>5,0 °C</b>		<b>A minimum temperature for releasing pump P2 can be adjusted. Note: If pump P2 should switch on e.g. at a temperature of 60 °C in the solar store (measured at S3), adjust the following values: MN3O = 55 °C MN3F = 60 °C. The pump will then be switched on again, if the temperature of 60 °C is reached. It will be blocked if the temperature falls below 55 °C.</b>
<b>MN3F</b>	switch-off threshold for minimum temperature	<b>10.0 °C</b>		
<b>OHQM</b>	option heat quantity measurement	<b>OFF</b>		
<b>CS 10</b>	solar irradiation sensor	<b>5</b>		
<b>n1MN</b>	minimum speed relay 1	<b>30</b>		
<b>n3MN</b>	minimum speed relay 3	<b>30</b>		
<b>HND1</b>	manual operation relay 1	<b>AUTO</b>		
<b>HND2</b>	manual operation relay 2	<b>AUTO</b>		
<b>HND3</b>	manual operation relay 3	<b>AUTO</b>		
<b>HND4</b>	manual operation relay 4	<b>AUTO</b>		
<b>HND5</b>	manual operation relay 5	<b>AUTO</b>		
<b>HND6</b>	manual operation relay 6	<b>AUTO</b>		
<b>LANG</b>	language	<b>dE</b>		<b>dE = German En = English It = Italian Fr = French</b>
<b>PROG</b>	program number	<b>xx.xx</b>		
<b>VERS</b>	version number	<b>x.xx</b>		



## System Arrangement 3

### System description:

The controller calculates the temperature difference between collector sensor S1 and store sensor S2. If the difference is larger than or identical to the adjusted switch-on temperature difference, pump P1 will be switched on and

the store will be loaded until the switch-off temperature difference or the maximum store temperature is reached. Domestic hot water afterheating (P2) can be carried out with a thermostat function (S3).

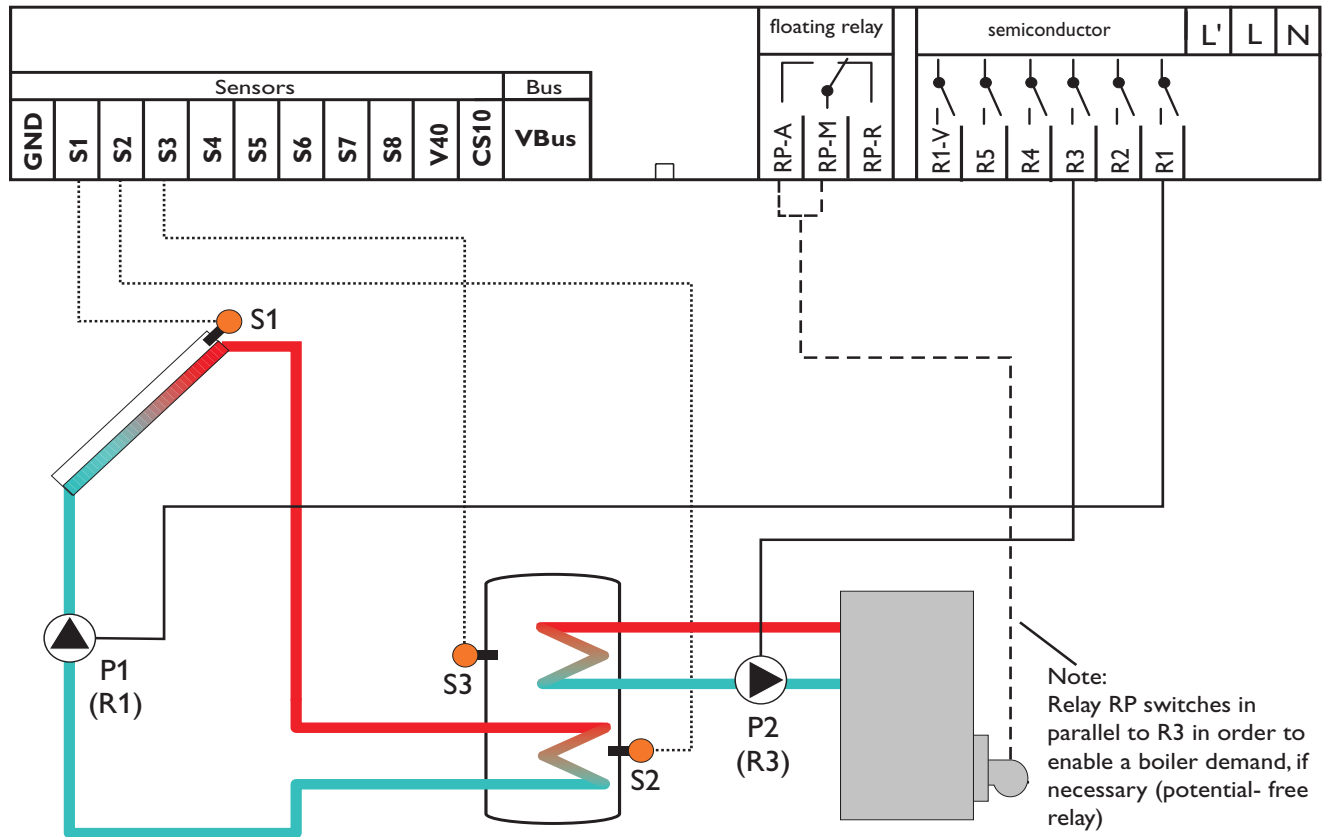

Sensor input	description
S1	temperature collector
S2	temperature store base
S3	temperature store top (DWH afterheating)
CS10 (optional)	irradiation

channel	description	factory setting	change to	note
COL	temperature collector	-----		
TSTB	temperature store base	-----		
TSTU	temperature store 1 top	-----		
IRR	irradiation	-----		
n %	speed relay	-----		
h P	operating hours relay	-----		
h P3	operating hours relay 3	-----		
TIME	time	-----		Adjust the actual clock time.
Arr	arrangement choice	1	3	Arrangement 3: 1-store solar system with domestic hot water afterheating
DT O	switch-on temperature difference	6,0 K		Adjust the desired switch-on temperature difference
DT F	switch-off temperature difference	4,0 K		Adjust the desired switch-off temperature difference
DT S	set temperature difference	10,0 K		Adjust the desired set temperature difference
RIS	rise	2 K		If the adjusted temperature difference DTS is reached and if the temperature increases by the difference RIS, the speed will be increased by 10% respectively.
S MX	maximum store temperature	60 °C		Adjust the desired maximum store temperature
EM	collector emergency temperature	140 °C		Adjust this value to 200°C when the collector emergency shutdown function should not start.
OCX	option collector cooling	OFF		
OCN	option minimum limitation collector	OFF		
OCF	option collector frost protection	OFF		
OREC	option recooling	OFF		
OTC	option tube collector	OFF		
NH O	switch-on temperature thermostat 1	40.0 °C		Adjust the desired switch-on temperature difference for heat exchange control
NH F	switch-off temperature thermostat 1	45.0 °C		Adjust the desired switch-off temperature difference for heat exchange control
t1 O	time frame 1 switch-on temperature	00:00		<p>Up to 3 additional time frames can be selected for the thermostat function (DHW afterheating). The thermostat function (DHW afterheating) will be active within these time frames only.</p> <p>Example: If the thermostat function (DHW afterheating) should run between 06:00 a.m. and 08:00 a.m. and 06:00 p.m. and 07:00 p.m., adjust t1 O to 06:00 a.m., t1 F to 08:00 a.m., t2 O to 06:00 p.m. and t2 F to 07:00 p.m. If all time frames are set to 00:00, the thermostat function (domestic hot water afterheating) is always activated (factory setting).</p>

channel	description	factory setting	change to	note
t1 F	time frame 1 switch-off temperature	00:00		
t2 O	time frame 2 switch-on temperature	00:00		
t2 F	time frame 2 switch-off temperature	00:00		
t3 O	time frame 3 switch-on temperature	00:00		
t3 F	time frame 3 switch-off temperature	00:00		
OHQM	option heat quantity measurement	OFF		
CS 10	solar irradiation sensor	5		
n MN	minimum speed relay 1	30		
HND1	manual operation relay 1	AUTO		
HND2	manual operation relay 2	AUTO		
HND3	manual operation relay 3	AUTO		
HND4	manual operation relay 4	AUTO		
HND5	manual operation relay 5	AUTO		
HND6	manual operation relay 6	AUTO		
LANG	language	dE		dE = German En = English It = Italian Fr = French
PROG	program number	xx.xx		
VERS	version number	x.xx		

## System Arrangement 4

### System description:

The controller compares the temperature at sensor S1 to the temperatures at sensors S2 and S3. If the measured temperature differences are higher than the adjusted switch-on temperature differences, the pump (P1) will be activated

and the corresponding store zone will be loaded up to the adjusted maximum temperature at most via the valve (V1). The priority logic causes priority loading of the upper zone of the store.

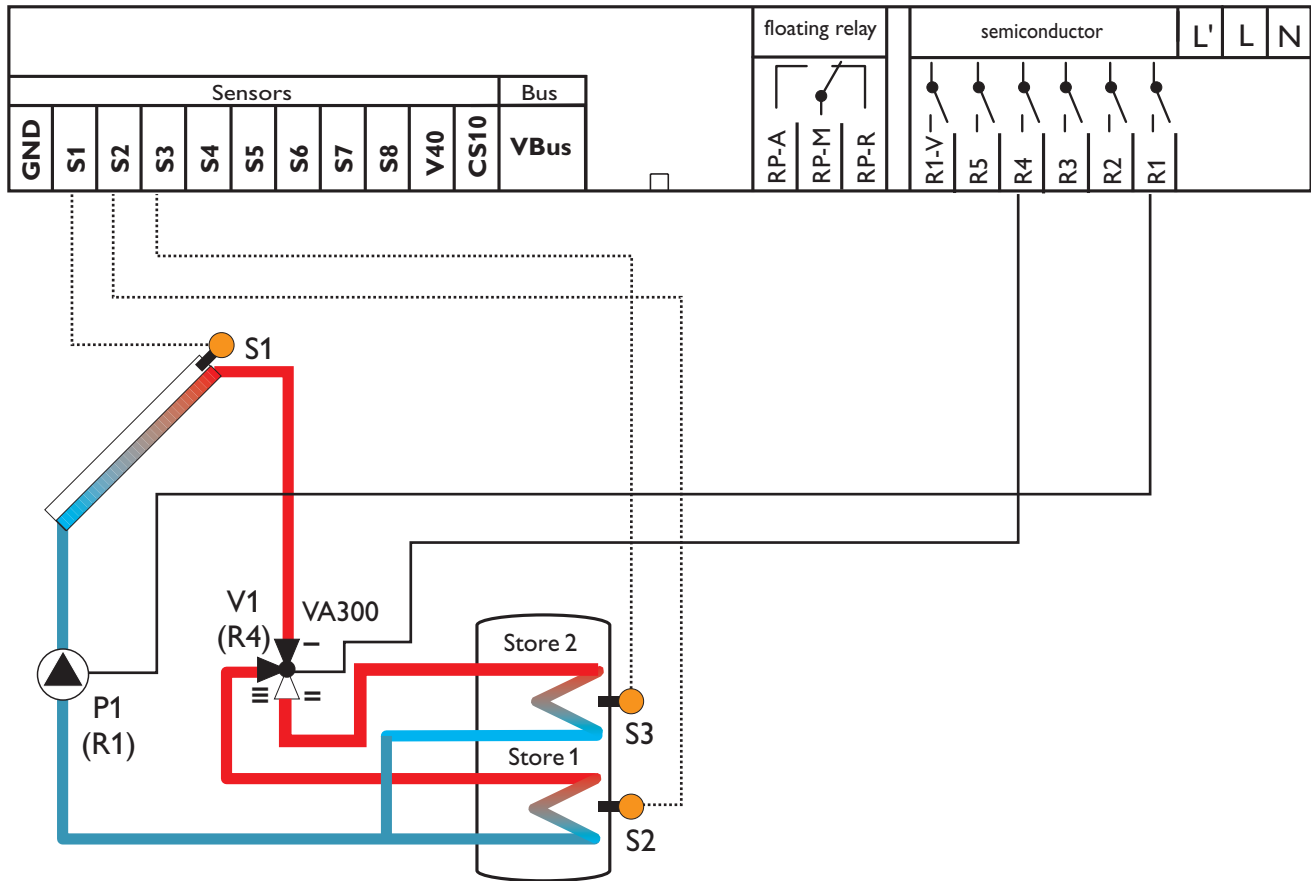

Relay output	Note
R1	solar pump (P1) with speed control
R2	
R3	
R4	3-port valve (V1) store top/base
R5	
RP-R	
RP-M	
RP-A	

Sensor input	description
S1	temperature collector
S2	temperature store base
S3	temperature store top
CS10 (optional)	irradiation

channel	description	factory setting	change to	note
COL	temperature collector	-----		
TSTB	temperature store base	-----		
TSTU	temperature store 1 top	-----		
IRR	irradiation	-----		
n %	speed relay	-----		
h P	operating hours relay	-----		
TIME	time	-----		Adjust the actual clock time.
Arr	arrangement choice	1	4	Arrangement 4: Solar system with multi-layer-store
DT1O	switch-on temperature difference 1	6.0 K		Adjust the desired switch-on temperature difference for store 1.
DT1F	switch-off temperature difference 1	4.0 K		Adjust the desired switch-off temperature difference for store 1.
DT1S	set temperature difference 1	10.0 K		Adjust the desired set temperature difference for store 1.
RIS1	rise 1	2 K		If the adjusted temperature difference DT1S is reached and if the temperature increases by the difference RIS1, the speed will be increased by 10% respectively.
S1MX	maximum temperature store 1	60		Adjust the desired maximum store temperature for store 1.
DT2O	switch-on temperature difference 2	6.0 K		Adjust the desired switch-on temperature difference for store 2.
DT2F	switch-off temperature difference 2	4.0 K		Adjust the desired switch-off temperature difference for store 2.
DT2S	set temperature difference 2	10.0 K		Adjust the desired set temperature difference for store 2.
RIS2	rise 2	2 K		If the adjusted temperature difference DT2S is reached and if the temperature increases by the difference RIS2, the speed will be increased by 10% respectively.
S2MX	maximum temperature store 2	60°C		Adjust the desired maximum store temperature for store 2.
EM	collector emergency temperature	140 °C		Adjust this value to 200°C when the collector emergency shutdown function should not start.
OCX	Option collector cooling	OFF		
OCN	Option minimum limitation	OFF		
OCF	Option frost protection	OFF		
PRIO	priority	2		priority store top
tST	break time	2 Min.		The loading break time for the priority logic function can be changed (see appendix priority logic)
tRUN	runtime	15 Min.		The oscillating loading time for the priority logic function can be changed (see appendix priority logic)
OREC	option recooling	OFF		
OTC	option tube collector	OFF		
OHQM	option heat quantity measurement	OFF		
CS 10	solar irradiation sensor	5		

channel	description	factory setting	change to	note
n MN	minimum speed relay 1	30		
HND1	manual operation relay 1	AUTO		
HND2	manual operation relay 2	AUTO		
HND3	manual operation relay 3	AUTO		
HND4	manual operation relay 4	AUTO		
HND5	manual operation relay 5	AUTO		
HND6	manual operation relay 6	AUTO		
LANG	language	dE		dE = German En = English It = Italian Fr = French
PROG	program number	xx.xx		
VERS	version number	x.xx		

Information on priority logic can be found on page 115.

## System Arrangement 5

### System description:

The controller compares the temperature at sensor S1 to the temperatures at sensors S2 and S4. If the measured temperature differences are higher than the adjusted switch-on

temperature differences, the pump (P1) will be activated and the corresponding store will be loaded up to the adjusted maximum temperature at most via the valve (V1).

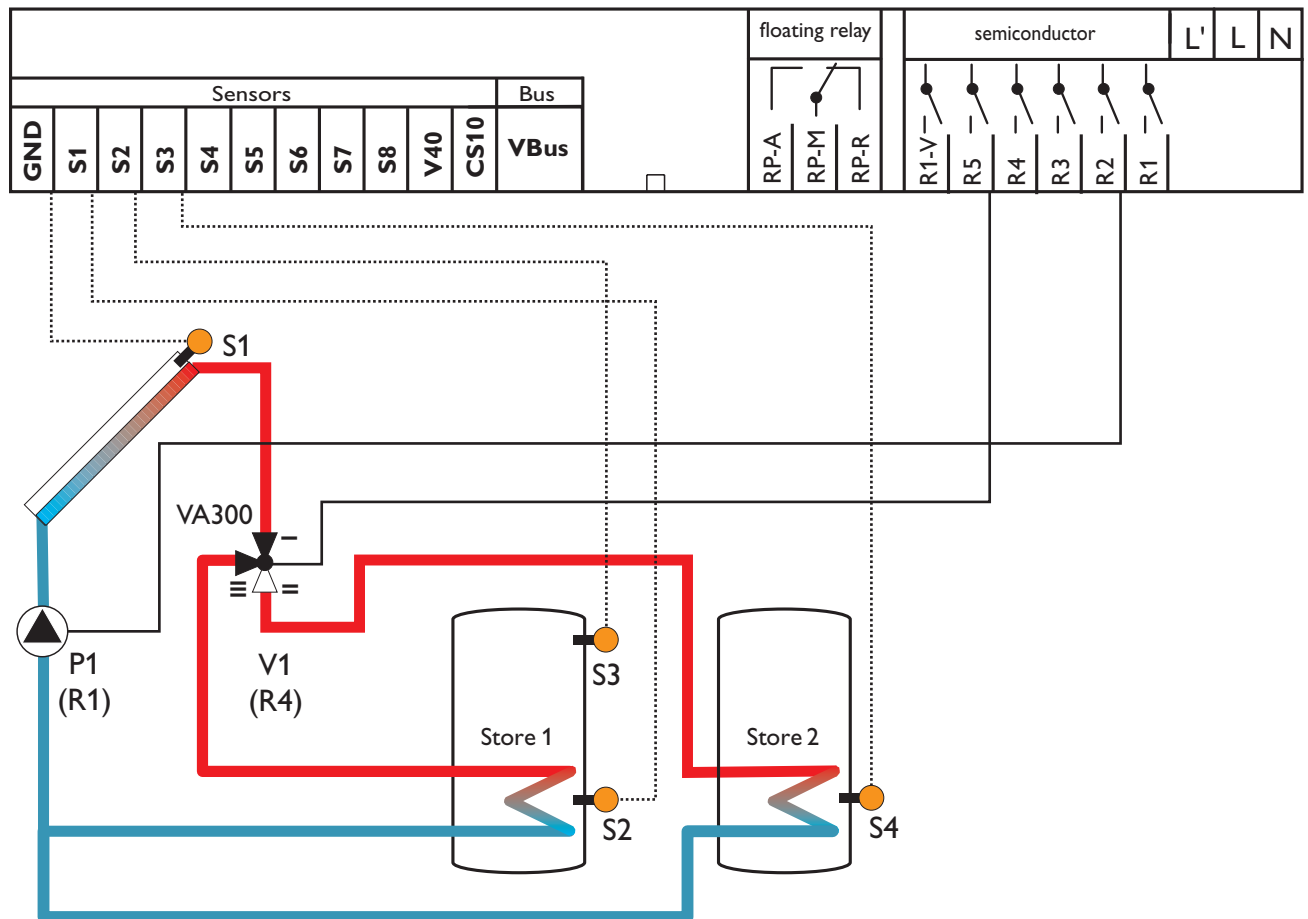

Relay output	Note
R1	solar pump (P1) with speed control
R2	
R3	
R4	3-port valvel (V1) store 1 / 2
R5	
RP-R	
RP-M	
RP-A	

Sensor input	description
S1	temperature collector
S2	temperature store 1 base
S3	temperature store 1 top
S4	temperature store 2 base
CS10 (optional)	irradiation

channel	description	factory setting	change to	note
COL	temperature collector	-----		
TST1	temperature store 1 base	-----		
TSTU	temperature store 1 top	-----		
TST2	temperature store 2 base	-----		
IRR	irradiation	-----		
n %	speed relay	-----		
h P	operating hours relay	-----		
TIME	time	-----		Adjust the actual clock time.
Arr	arrangement choice	1	5	Arrangement 5: 2-store system, valve control
DT1O	switch-on temperature difference 1	6.0 K		Adjust the desired switch-on temperature difference for store 1.
DT1F	switch-off temperature difference 1	4.0 K		Adjust the desired switch-off temperature difference for store 1.
DT1S	set temperature difference 1	10.0 K		Adjust the desired set temperature difference for store 1.
RIS1	rise 1	2 K		If the adjusted temperature difference DT1S is reached and if the temperature increases by the difference RIS1, the speed will be increased by 10% respectively.
S1MX	maximum temperature store 1	60		Adjust the desired maximum store temperature for store 1.
DT2O	switch-on temperature difference 2	6.0 K		Adjust the desired switch-on temperature difference for store 2.
DT2F	switch-off temperature difference 2	4.0 K		Adjust the desired switch-off temperature difference for store 2.
DT2S	set temperature difference 2	10.0 K		Adjust the desired set temperature difference for store 2.
RIS2	rise 2	2 K		If the adjusted temperature difference DT2S is reached and if the temperature increases by the difference RIS2, the speed will be increased by 10% respectively.
S2MX	maximum temperature store 2	60		Adjust the desired maximum store temperature for store 2.
EM	collector emergency temperature	140 °C		Adjust this value to 200°C when the collector emergency shutdown function should not start.
OCX	Option collector cooling	OFF		
OCN	Option minimum limitation	OFF		
OCF	Option frost protection	OFF		
PRIO	priority	1		priority store 1, store 2 subordinate
tST	break time	2 Min.		The loading break time for the priority logic function can be changed (see appendix priority logic)
tRUN	runtime	15 Min.		The oscillating loading time for the priority logic function can be changed (see appendix priority logic)
OREC	option recooling	OFF		
OTC	option tube collector	OFF		



channel	description	factory setting	change to	note
<b>OHQM</b>	option heat quantity measurement	<b>OFF</b>		
<b>CS 10</b>	solar irradiation sensor	<b>5</b>		
<b>n MN</b>	minimum speed relay 1	<b>30</b>		
<b>HND1</b>	manual operation relay 1	<b>AUTO</b>		
<b>HND2</b>	manual operation relay 2	<b>AUTO</b>		
<b>HND3</b>	manual operation relay 3	<b>AUTO</b>		
<b>HND4</b>	manual operation relay 4	<b>AUTO</b>		
<b>HND5</b>	manual operation relay 5	<b>AUTO</b>		
<b>HND6</b>	manual operation relay 6	<b>AUTO</b>		
<b>LANG</b>	language	<b>dE</b>		<b>dE = German En = English It = Italian Fr = French</b>
<b>PROG</b>	program number	<b>xx.xx</b>		
<b>VERS</b>	version number	<b>x.xx</b>		

Information on priority logic can be found on page 115.

## System Arrangement 6

### System description:

The controller compares the temperature at sensor S1 to the temperatures at sensors S2 and S4. If the measured temperature differences are higher than the adjusted switch-on temperature differences, the pump (P1 or P2) will be

activated and the corresponding store will be loaded up to the adjusted maximum temperature at most.

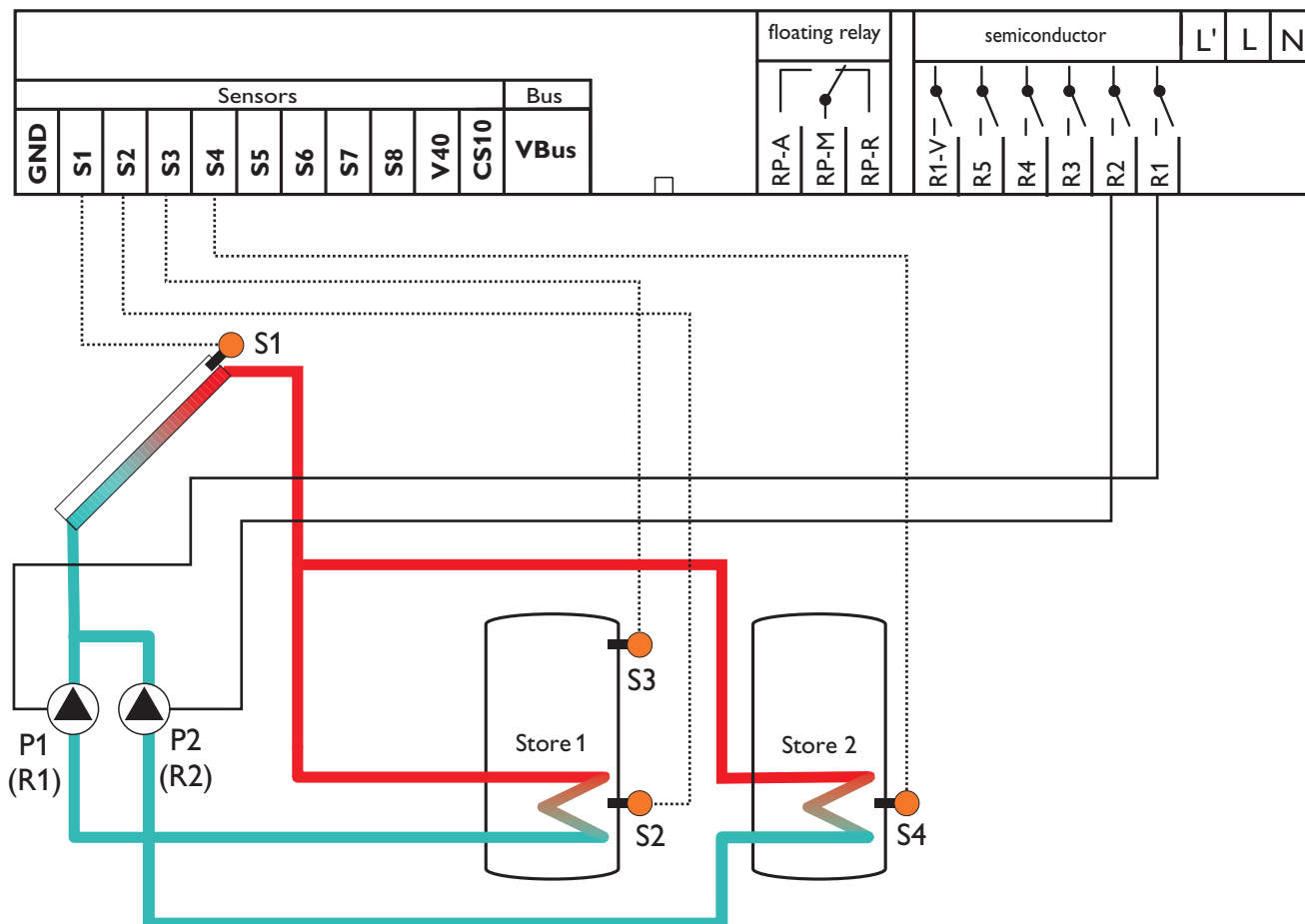

Relay output	Note
R1	solar pump (P1) with speed control
R2	solar pump (P1) with speed control
R3	
R4	
R5	
RP-R	
RP-M	
RP-A	

Sensor input	description
S1	temperature collector
S2	temperature store 1 base
S3	temperature store 1 top
S4	temperature store 2 base
CS10 (optional)	irradiation

channel	description	factory setting	change to	note
COL	temperature collector	-----		
TST1	temperature store 1 base	-----		
TSTU	temperature store 1 top	-----		
TST2	temperature store 2 base	-----		
IRR	irradiation	-----		
n1 %	speed relay 1	-----		
n1 %	speed relay 2	-----		
h P1	operating hours relay 1	-----		
h P2	operating hours relay 2	-----		
TIME	Time	-----		Adjust the actual clock time.
Arr	arrangement choice	1	6	Arrangement 6: 2-store system, pump control
DT1O	switch-on temperature difference 1	6.0 K		Adjust the desired switch-on temperature difference for store 1.
DT1F	switch-off temperature difference 1	4.0 K		Adjust the desired switch-off temperature difference for store 1.
DT1S	set temperature difference 1	10.0 K		Adjust the desired set temperature difference for store 1.
RIS1	rise 1	2 K		If the adjusted temperature difference DT2S is reached and if the temperature increases by the difference RIS2, the speed will be increased by 10% respectively.
S1MX	maximum temperature store 1	60 °C		Adjust the desired maximum store temperature for store 1.
DT2O	switch-on temperature difference 2	6.0 K		Adjust the desired switch-on temperature difference for store 2.
DT2F	switch-off temperature difference 2	4.0 K		Adjust the desired switch-off temperature difference for store 2.
DT2S	set temperature difference 2	10.0 K		Adjust the desired set temperature difference for store 2.
RIS2	rise 2	2 K		If the adjusted temperature difference DT2S is reached and if the temperature increases by the difference RIS2, the speed will be increased by 10% respectively.
S2MX	maximum temperature store 2	60 °C		Adjust the desired maximum store temperature for store 2.
EM	collector emergency temperature	140 °C		Adjust this value to 200 °C when the collector emergency shutdown function should not start.
OCX	Option collector cooling	OFF		
OCN	Option minimum limitation	OFF		
OCF	Option frost protection	OFF		
PRIO	priority	1		priority store 1, store 2 subordinated
tST	break time	2 Min.		The loading break time for the priority logic function can be changed (see appendix priority logic)

channel	description	factory setting	change to	note
tRUN	runtime	15 Min.		The oscillating loading time for the priority logic function can be changed (see appendix priority logic)
OREC	option recooling	OFF		
OTC	option tube collector	OFF		
OHQM	option heat quantity measurement	OFF		
CS 10	solar irradiation sensor	5		
n MN	minimum speed relay 1	30		
HND1	manual operation relay 1	AUTO		
HND2	manual operation relay 2	AUTO		
HND3	manual operation relay 3	AUTO		
HND4	manual operation relay 4	AUTO		
HND5	manual operation relay 5	AUTO		
HND6	manual operation relay 6	AUTO		
LANG	language	dE		dE = German En = English It = Italian Fr = French
PROG	program number	xx.xx		
VERS	version number	x.xx		

Information on priority logic can be found on page 115.

## System Arrangement 7

### System description:

The controller compares the temperatures at the collector sensors S1 and S6 to the store temperature at store sensor S2. If one of the measured temperature differences is

higher than the adjusted switch-on temperature differences, the corresponding pump (P1, P2) will be activated and the store will be loaded.

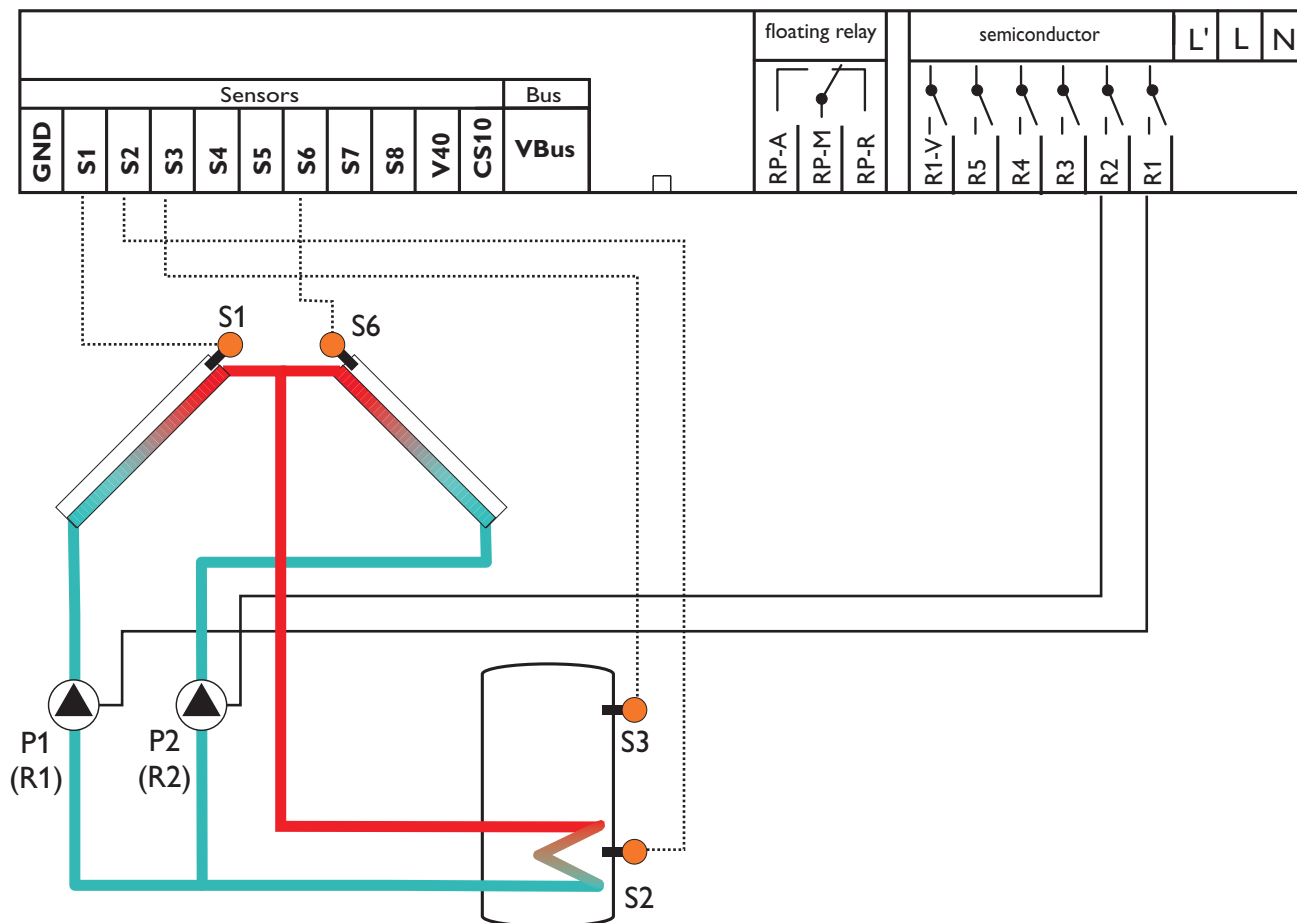

Relay output	Note
R1	solar pump (P1) with speed control
R2	solar pump (P2) with speed control
R3	
R4	
R5	
RP-R	
RP-M	
RP-A	

Sensor input	description
S1	temperature collector 1
S2	temperature store base
S3	temperature store top
S6	temperature collector 2
CS10 (optional)	irradiation

channel	description	factory setting	change to	note
COL1	temperature collector 1	-----		
TSTL	temperature store base	-----		
COL2	temperature collector 2	-----		
IRR	irradiation	-----		
n1 %	speed relay 1	-----		
n2 %	speed relay 2	-----		
h P1	operating hours relay 1	-----		
h P2	operating hours relay 2	-----		
TIME	time	-----		Adjust the actual clock time.
Arr	arrangement choice	1	7	Arrangement 7: 2 collector-system (east-/west collectors) with 1 store
DT O	switch-on temperature difference	6.0 K		Adjust the desired switch-on temperature difference Note: This value applies to collector 1 and 2
DT F	switch-off temperature difference	4.0 K		Adjust the desired switch-off temperature difference Note: This value applies to collector 1 and 2
DT S	set temperature difference	10.0 K		Adjust the desired set temperature difference note: This values applies to collector 1 and 2
RIS	rise	2 K		If the adjusted temperature difference DTS is reached and if the temperature increases by the difference RIS, the speed will be increased by 10% respectively. Note: This value applies to collector 1 and 2
S MX	maximum store temperature	60 °C		Adjust the desired maximum store temperature
EM1	emergency temperature collector 1	140 °C		Adjust this value to 200°C when the collector emergency shutdown function should not start.
OCX1	option collector cooling collector 1	OFF		
OCN1	option minimum limitation collector 1	OFF		
OCF1	option frost protection collector 1	OFF		Adjust this value to 200°C when the collector emergency shutdown function should not start.
EM2	emergency temperature collector 2	140 °C		
OCX2	option collector cooling collector 2	OFF		
OCN2	option minimum limitation collector 2	OFF		
OCF2	option frost protection collector 2	OFF		
OREC	option recooling	OFF		
O TC	option tube collector	OFF		

channel	description	factory setting	change to	note
<b>OHQM</b>	option heat quantity measurement	<b>OFF</b>		
<b>CS 10</b>	solar irradiation sensor	<b>5</b>		
<b>n1MN</b>	minimum speed relay 1	<b>30</b>		
<b>n2MN</b>	minimum speed relay 2	<b>30</b>		
<b>HND1</b>	manual operation relay 1	<b>AUTO</b>		
<b>HND2</b>	manual operation relay 2	<b>AUTO</b>		
<b>HND3</b>	manual operation relay 3	<b>AUTO</b>		
<b>HND4</b>	manual operation relay 4	<b>AUTO</b>		
<b>HND5</b>	manual operation relay 5	<b>AUTO</b>		
<b>HND6</b>	manual operation relay 6	<b>AUTO</b>		
<b>LANG</b>	language	<b>dE</b>		<b>dE = German En = English It = Italian Fr = French</b>
<b>PROG</b>	program number	<b>xx.xx</b>		
<b>VERS</b>	version number	<b>x.xx</b>		

## System Arrangement 8

### System description:

The controller calculates the temperature difference between collector sensor S1 and store sensor S2. If the difference is larger than or identical to the adjusted switch-on temperature difference, pump P1 will be switched on and the store will be loaded until the switch-off temperature

difference or the maximum store temperature is reached. Via another temperature differential function (S3/S4), after heating of the store can be carried out with a solid fuel boiler (P2).

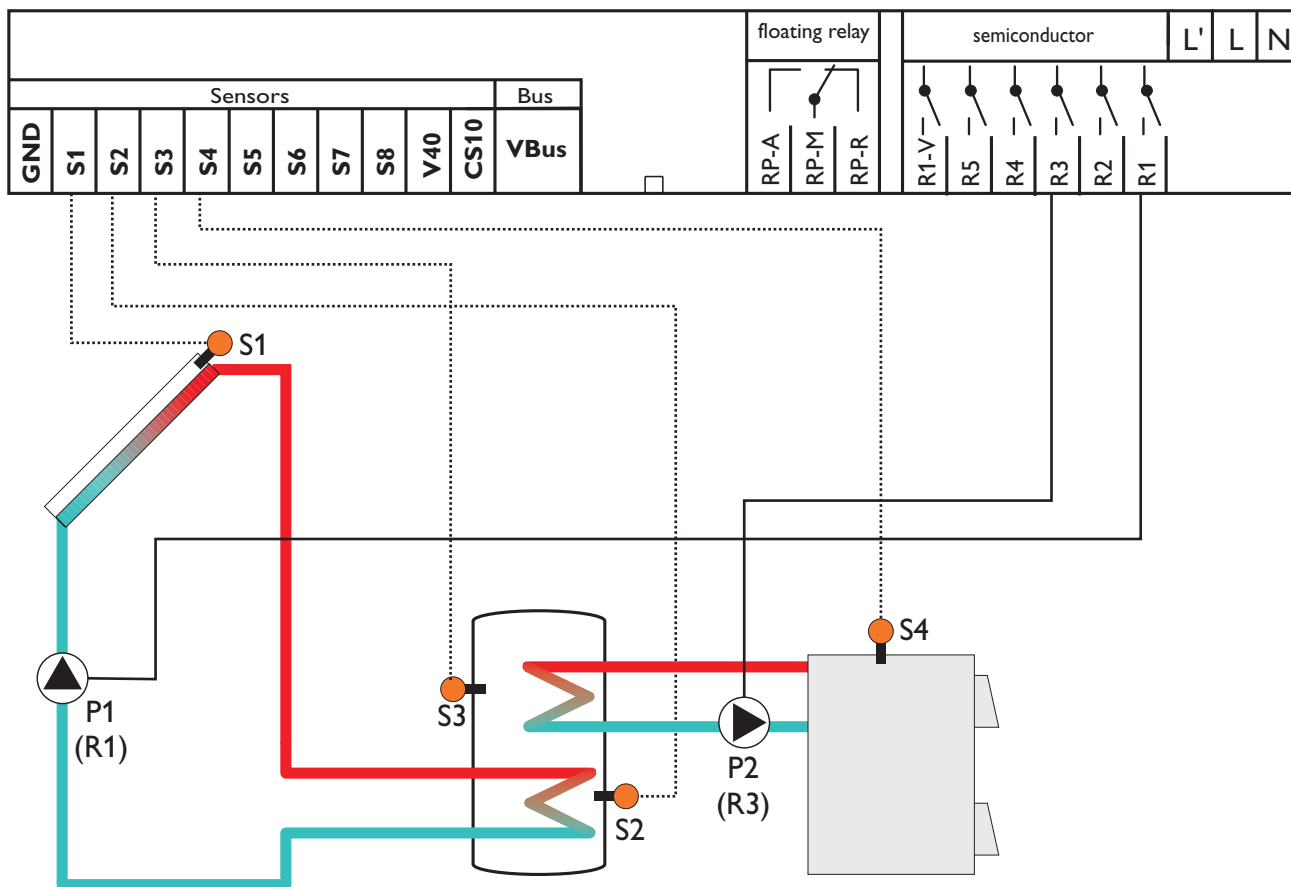

Relay output	Note
R1	solar pump (P1) with speed control
R2	pump solid fuel boiler (P2) speed-controlled
R3	
R4	
R5	
RP-R	
RP-M	
RP-A	

Sensor input	description
S1	temperature collector
S2	temperature store base
S3	temperature store top
S4	temperature solid fuel boiler
CS10 (optional)	irradiation



channel	description	factory setting	change to	note
COL	temperature collector	-----		
TSTL	temperature store base	-----		
TSTU	temperature store 1 top	-----		
TSFB	temperature solid fuel boiler	-----		
IRR	irradiation	-----		
n1 %	speed relay 1	-----		
n3 %	speed relay 2	-----		
h P1	operating hours relay 1	-----		
h P3	operating hours relay 3	-----		
TIME	time	-----		Adjust the actual clock time.
Arr	arrangement choice	1	8	Arrangement 8: 1-store system with after-heating via solid fuel boiler
DT O	switch-on temperature difference	6.0 K		Adjust the desired switch-on temperature difference
DT F	switch-off temperature difference	4.0 K		Adjust the desired switch-off temperature difference
DT S	set temperature difference	10.0 K		Adjust the desired set temperature difference
RIS	rise	2 K		If the adjusted temperature difference DTS is reached and if the temperature increases by the difference RIS, the speed will be increased by 10% respectively.
S MX	maximum store temperature	60 °C		Adjust the desired maximum store temperature
EM	collector emergency temperature	140 °C		Adjust this value to 200°C when the collector emergency shutdown function should not start.
OCX	Option collector cooling	OFF		
OCN	Option minimum limitation	OFF		
OCF	Option frost protection	OFF		
OREC	option recooling	OFF		
OTC	option tube collector	OFF		
OCF2	option frost protection collector 2	OFF		
OREC	option recooling	OFF		
OTC	option tube collector	OFF		
DT3O	switch-on temperature difference 3	6.0 K		Adjust the desired switch-on temperature difference for solid fuel boiler pump
DT3F	switch-off temperature difference 3	4.0 K		Adjust the desired switch-off temperature difference for solid fuel boiler pump
DT3S	set temperature DT3	10.0 K		Adjust the desired set temperature difference for solid fuel boiler pump
RIS3	rise DT3	2 K		If the adjusted temperature difference DT3S is reached and if the temperature increases by the difference RIS3, speed relay 3 will be increased by 10% respectively.

channel	description	factory setting	change to	note
<b>MX3O</b>	switch-on threshold for maximum temperature	60,0 °C		Adjust the desired maximum store temperature for switching of the solid fuel burner pump (P2) <b>Note:</b> When the maximum store temperature (MX3O) at sensor S3 is reached, pump P2 is switched off. When the store temperature falls below MX3F at S3, the pump is switched-on again.
<b>MX3F</b>	switch-off threshold for maximum temperature	58.0 °C		
<b>MN3O</b>	switch-on threshold for minimum temperature	60,0°C		Adjust the desired minimum temperature for releasing pump P2. <b>Note:</b> Pump 2 is switched on when the solid fuel boiler (S4) reaches 65 °C (MN3F) and when there is a temperature difference (DT3O) to store sensor S3. It is switched off when the temperature of the solid fuel boiler falls to 60 °C (MN3O), the temperature difference falls below the switch-off temperature difference (DT3F) or when the store maximum temperature (MX3O) at sensor S3 is reached.
<b>MN3F</b>	switch-off threshold for minimum temperature	65.0 °C		
<b>OHQM</b>	option heat quantity measurement	OFF		
<b>CS 10</b>	solar irradiation sensor	5		
<b>n1MN</b>	minimum speed relay 1	30		
<b>n3MN</b>	minimum speed relay 3	30		
<b>HND1</b>	manual operation relay 1	AUTO		
<b>HND2</b>	manual operation relay 2	AUTO		
<b>HND3</b>	manual operation relay 3	AUTO		
<b>HND4</b>	manual operation relay 4	AUTO		
<b>HND5</b>	manual operation relay 5	AUTO		
<b>HND6</b>	manual operation relay 6	AUTO		
<b>LANG</b>	language	dE		dE = German En = English It = Italian Fr = French
<b>PROG</b>	program number	xx.xx		
<b>VERS</b>	version number	x.xx		

## System Arrangement 9

### System description:

The controller calculates the temperature difference between collector sensor S1 and store sensor S2. If the difference is larger than or identical to the adjusted switch-on temperature difference, pump P1 will be switched on and the store will be loaded until the switch-off temperature

difference or the maximum store temperature is reached. With another temperature differential function (S3/S5) heating circuit return preheating (heating circuit backup) is possible via V1.

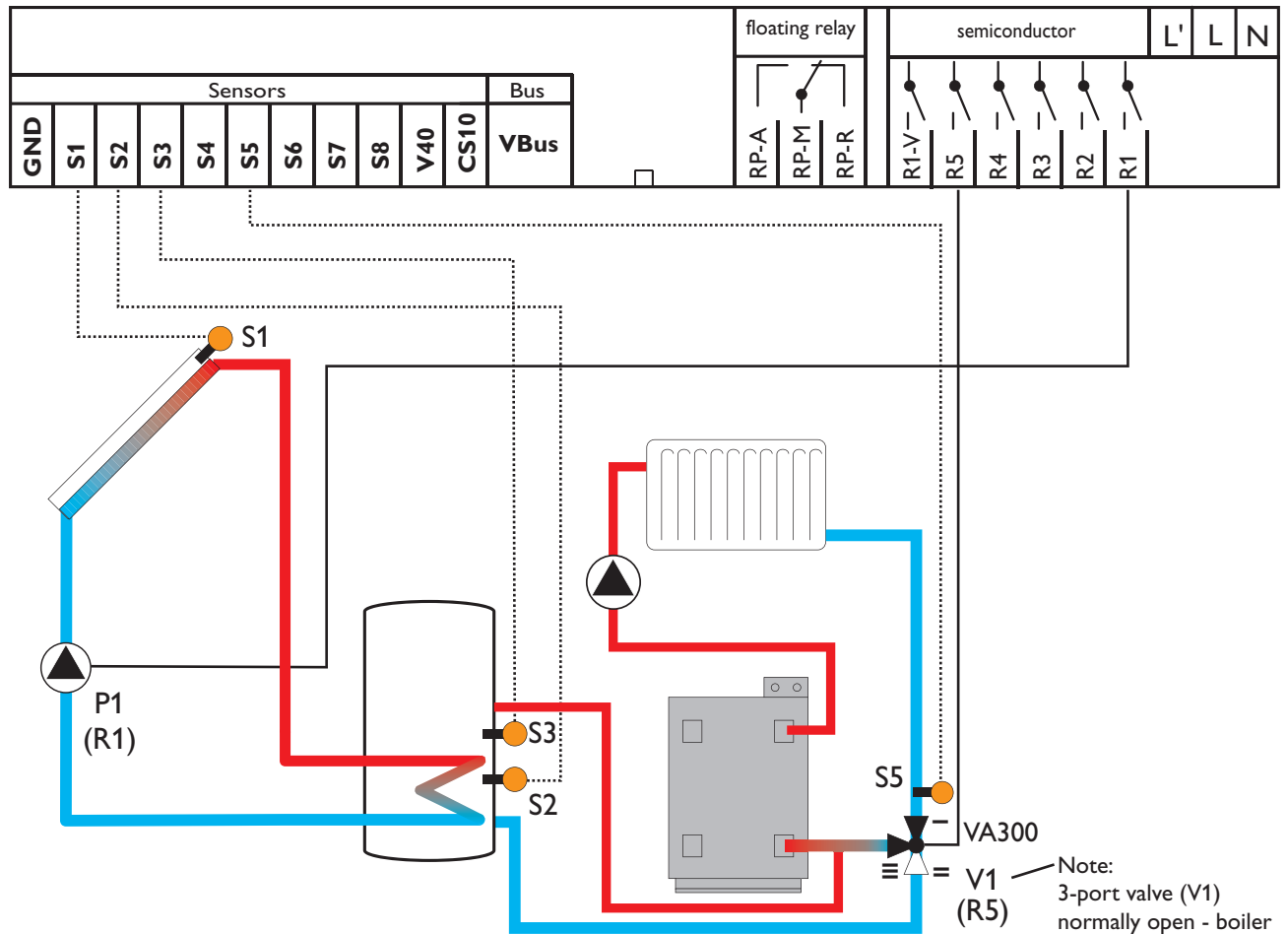

Relay output	Note
R1	solar pump (P1) with speed control
R2	
R3	
R4	
R5	3-port valve (V1) heating circuit return preheating
RP-R	
RP-M	
RP-A	

Sensor input	description
S1	temperature collector
S2	temperature store base
S3	temperature store center
S5	temperature heating circuit
CS10 (optional)	irradiation

channel	description	factory setting	change to	note
COL	temperature collector	-----		
TSTL	temperature store base	-----		
TSTU	temperature store 1 top	-----		
TREC	temperature heating circuit	-----		
IRR	irradiation	-----		
n %	speed relay	-----		
h P	operating hours relay	-----		
TIME	time	-----		Adjust the actual clock time.
Arr	arrangement choice	1	9	Arrangement 9: 1store-system with heating circuit return pre-heating
DT O	switch-on temperature difference	6.0 K		Adjust the desired switch-on temperature difference
DT F	switch-off temperature difference	4.0 K		Adjust the desired switch-off temperature difference
DT S	set temperature difference	10.0 K		Adjust the desired set temperature difference
RIS	rise	2 K		If the adjusted temperature difference DTS is reached and if the temperature increases by the difference RIS, the speed will be increased by 10% respectively.
S MX	maximum store temperature	60 °C		Adjust the desired maximum store temperature
EM	collector emergency temperature	140 °C		Adjust this value to 200°C when the collector emergency shutdown function should not start.
OCX	Option collector cooling	OFF		
OCN	Option minimum limitation	OFF		
OCF	Option frost protection	OFF		
OREC	option recooling	OFF		
OTC	option tube collector	OFF		
DT3O	switch-on temperature difference 3	6.0 K		Adjust the desired switch-on temperature difference for heating circuit return preheating (heating circuit backup) .
DT3F	switch-off temperature difference 3	4.0 K		Adjust the desired switch-off temperature difference for heating circuit return preheating (heating circuit backup).

channel	description	factory setting	change to	note
<b>CS 10</b>	solar irradiation sensor	5		
<b>n MN</b>	minimum speed relay 1	30		
<b>HND1</b>	manual operation relay 1	<b>AUTO</b>		
<b>HND2</b>	manual operation relay 2	<b>AUTO</b>		
<b>HND3</b>	manual operation relay 3	<b>AUTO</b>		
<b>HND4</b>	manual operation relay 4	<b>AUTO</b>		
<b>HND5</b>	manual operation relay 5	<b>AUTO</b>		
<b>HND6</b>	manual operation relay 6	<b>AUTO</b>		
<b>LANG</b>	language	dE		dE = German En = English It = Italian Fr = French
<b>PROG</b>	program number	xx.xx		
<b>VERS</b>	version number	x.xx		

## System Arrangement 10

### System description:

The controller calculates the temperature difference between collector sensor S1 and store sensor S2. If the difference is larger than or identical to the adjusted switch-on temperature difference, pump P1 will be switched on and the store will be loaded until the switch-off temperature

difference or the maximum store temperature is reached. Via another temperature differential function (S3/S5) heating circuit backup (heating circuit return preheating) is possible via V1. Via a thermostat function (S3) domestic hot water afterheating (P2) can be carried out.

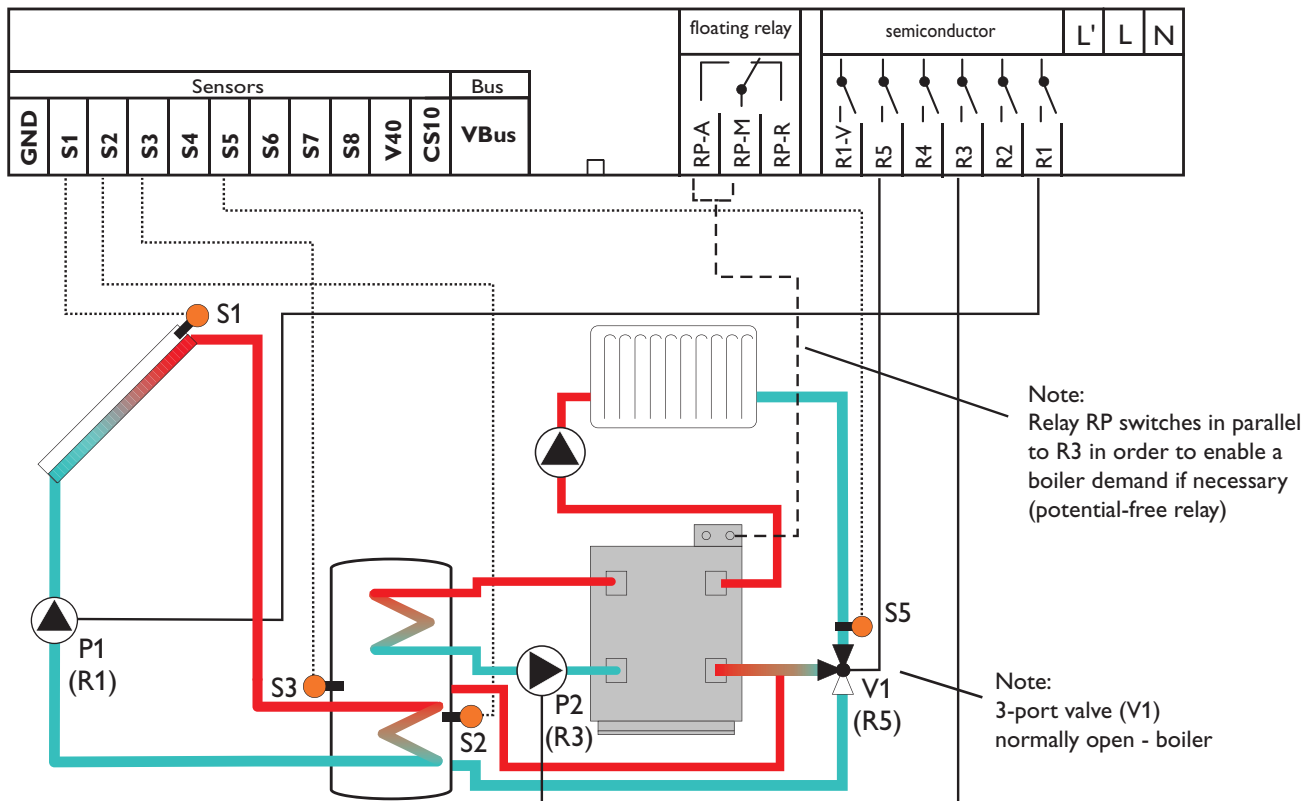

Relay output	note
R1	solar pump (P1) with speed control
R2	
R3	pump domestic hot water afterheating (P2)
R4	
R5	3-port valve (V1) heating circuit return preheating
RP-R	
RP-M	boiler demand (potential-free), is switched on in parallel to R3
RP-A	

Sensor input	description
S1	temperature collector
S2	temperature store base
S3	temperature store center
S5	temperature heating circuit
CS10 (optional)	irradiation

channel	description	factory setting	change to	note
COL	temperature collector	-----		
TSTL	temperature store base	-----		
TSTU	temperature store 1 top	-----		
TREC	temperature heating circuit	-----		
IRR	irradiation	-----		
n %	speed relay	-----		
h P	operating hours relay	-----		
TIME	time	-----		Adjust the actual clock time.
Arr	arrangement choice	1	10	Arrangement 10: 1-store system with heating circuit backup and domestic hot water afterheating
DT O	switch-on temperature difference	6.0 K		Adjust the desired switch-on temperature difference
DT F	switch-off temperature difference	4.0 K		Adjust the desired switch-off temperature difference
DT S	set temperature difference	10.0 K		Adjust the desired set temperature difference
RIS	rise	2 K		If the adjusted temperature difference DTS is reached and if the temperature increases by the difference RIS, the speed will be increased by 10% respectively.
S MX	maximum store temperature	60 °C		Adjust the desired maximum store temperature
EM	collector emergency temperature	140 °C		Adjust this value to 200°C when the collector emergency shutdown function should not start.
OCX	Option collector cooling	OFF		
OCN	Option minimum limitation	OFF		
OCF	Option frost protection	OFF		
OREC	option recooling	OFF		
OTC	option tube collector	OFF		
DT3O	switch-on temperature difference 3	6.0 K		Adjust the desired switch-on temperature difference for heating circuit return preheating (heating circuit backup).
DT3F	switch-off temperature difference 3	4.0 K		Adjust the desired switch-off temperature difference for heating circuit return preheating (heating circuit backup).

channel	description	factory setting	change to	note
NH O	switch-on temperature thermostat 1	40.0 °C		Adjust the desired switch-on temperature for domestic hot water afterheating
NH F	switch-off temperature thermostat 1	45.0 °C		Adjust the desired switch-off temperature for domestic hot water afterheating
t1 O	time frame 1 switch-on temperature	00:00		<p>Up to 3 time frames can additionally be selected for the thermostat function (domestic hot water afterheating). The thermostat function (DHW afterheating) will be active within these time frames only.</p> <p>Example: If the thermostat function should run from 06:00 a.m. and 08:00 a.m.; and 06:00 p.m. and 07:00 p.m. only, adjust t1O to 06:00 a.m., t1F to 08:00 a.m., t2O to 06:00 p.m. and t2 F to 07:00 p.m..</p> <p>When all time frames are set to 00:00, the thermostat function (DHW afterheating) is always activated (factory setting).</p>
t1 F	time frame 1 switch-off temperature	00:00		
t2 O	time frame 2 switch-on temperature	00:00		
t2 F	time frame 2 switch-off temperature	00:00		
t3 O	time frame 3 switch-on temperature	00:00		
t3 F	time frame 3 switch-off temperature	00:00		
OHQM	option heat quantity measurement	OFF		
CS 10	solar irradiation sensor	5		
n MN	minimum speed relay 1	30		
HND1	manual operation relay 1	AUTO		
HND2	manual operation relay 2	AUTO		
HND3	manual operation relay 3	AUTO		
HND4	manual operation relay 4	AUTO		
HND5	manual operation relay 5	AUTO		
HND6	manual operation relay 6	AUTO		
LANG	language	dE		<p>dE = German</p> <p>En = English</p> <p>It = Italian</p> <p>Fr = French</p>
PROG	program number	xx.xx		
VERS	version number	x.xx		



## System Arrangement 11

### System description:

The controller compares the temperature at sensor S1 to the temperatures at sensors S2 and S3. If the measured temperature differences are higher than the adjusted switch-on temperature differences, the pump (P1) will be activated and the corresponding store zone will be loaded up to the adjusted maximum temperature at most via the valve (V1).

The priority logic causes priority loading of the upper zone of the store.

Heat transfer control to an existant store (P2) can be carried out via another temperature differential function (S3 heat source/S4 heat sink).

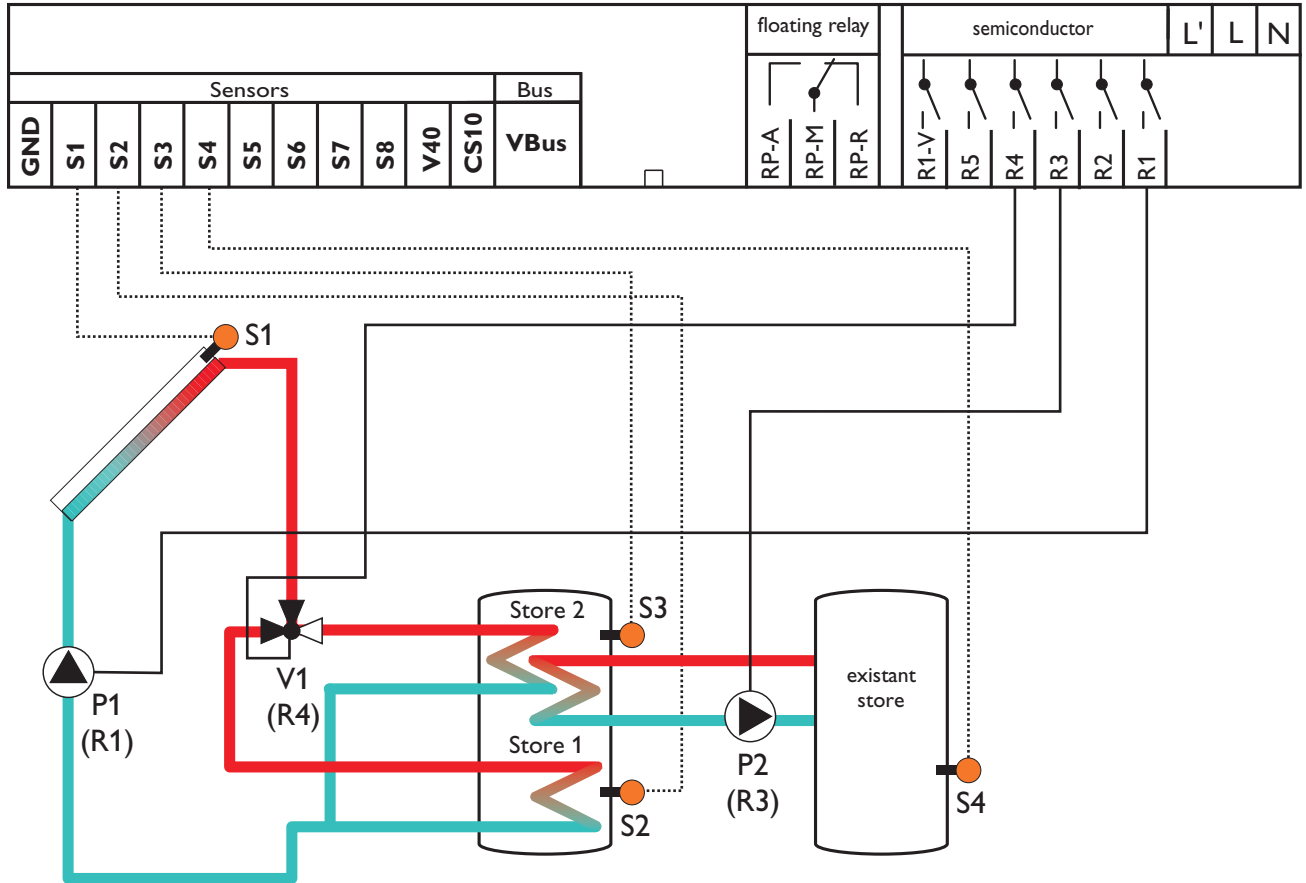

Note: 3-port valve V1 normally open - boiler

Relay output	Note
R1	solar pump (P1) with speed control
R2	
R3	pump heat exchange (P2)
R4	3-port valve (V1) store top/base
R5	
RP-R	
RP-M	
RP-A	

Sensor input	description
S1	temperature collector
S2	temperature store 1 base
S3	temperature store 1 top
S4	temperature store 2 base
CS10 (optional)	irradiation

channel	description	factory setting	change to	note
COL	temperature collector	-----		
TST1	temperature store 1 base	-----		
TSTU	temperature store 1 top	-----		
TST2	temperature store 2 base	-----		
IRR	irradiation	-----		
n1 %	speed relay 1	-----		
n3 %	speed relay 3	-----		
h P1	operating hours relay 1	-----		
h P3	operating hours relay 3	-----		
TIME	time	-----		Adjust the actual clock time.
Arr	arrangement choice	1	11	Arrangement 11: multi-layer store system with heat exchange control to existant store
DT1O	switch-on temperature difference 1	6.0 K		Adjust the desired switch-on temperature difference for store 1.
DT1F	switch-off temperature difference 1	4.0 K		Adjust the desired switch-off temperature difference for store 1.
DT1S	set temperature difference 1	10.0 K		Adjust the desired set temperature difference for store 1.
RIS1	rise 1	2 K		If the adjusted temperature difference DT1S is reached and if the temperature increases by the difference RIS1, the speed will be increased by 10% respectively.
S1MX	maximum temperature store 1	60		Adjust the desired maximum store temperature for store 1.
DT2O	switch-on temperature difference 2	6.0 K		Adjust the desired switch-on temperature difference for store 2.
DT2F	switch-off temperature difference 2	4.0 K		Adjust the desired switch-off temperature difference for store 2.
DT2S	set temperature difference 2	10.0 K		Adjust the desired set temperature difference for store 2.
RIS2	rise 2	2 K		If the adjusted temperature difference DT2S is reached and if the temperature increases by the difference RIS2, the speed will be increased by 10% respectively.
S2MX	maximum temperature store 2	60		Adjust the desired maximum store temperature for store 2.
EM	collector emergency temperature	140 °C		Adjust this value to 200°C when the collector emergency shutdown function should not start.
OCX	Option collector cooling	OFF		
OCN	Option minimum limitation	OFF		
OCF	Option frost protection	OFF		
PRIO	priority	2		priority store top
tST	break time	2 Min.		The loading break time for the priority logic function can be changed (see appendix priority logic)
tRUN	runtime	15 Min.		The oscillating loading time for the priority logic function can be changed (see appendix priority logic)
OREC	option recooling	OFF		

channel	description	factory setting	change to	note
OTC	option tube collector	OFF		
DT3O	switch-on temperature difference 3	6.0 K		Adjust the desired switch-on temperature difference for heat exchange control
DT3F	switch-off temperature difference 3	4.0 K		Adjust the desired switch-off temperature difference for heat exchange control
DT3S	set temperature DT3	10.0 K		Adjust the desired set temperature difference for heat exchange control
RIS3	rise DT3	2 K		If the adjusted temperature difference DT3S is reached and if the temperature increases by the difference RIS3, the speed relay 3 (P2) will be increased by 10% respectively.
MX3O	switch-on threshold for maximum temperature	60,0 °C		Adjust the desired maximum store temperature for the existing store (pump 2) Note: If the maximum store temperature (MX3O) at sensor S4 is reached, pump P2 is switched off. If the store temperature falls below MX3F at S4, the pump is switched-on again.
MX3F	switch-off threshold for maximum temperature	58.0 °C		
MN3O	switch-on threshold for minimum temperature	5,0 °C		A minimum temperature for releasing pump P2 can be adjusted. Note: If pump P2 should switch on e.g. at a temperature of 60 °C in the solar store (measured at S3), adjust the following values: MN3O = 55 °C, MN3F = 60 °C. The pump will then be switched on again, if 60 °C is reached. It will be blocked if the temperature falls below 55 °C.
MN3F	switch-off threshold for minimum temperature	10.0 °C		
OHQM	option heat quantity measurement	OFF		
CS 10	solar irradiation sensor	5		
n1MN	minimum speed relay 1	30		
n3MN	minimum speed relay 3	30		
HND1	manual operation relay 1	AUTO		
HND2	manual operation relay 2	AUTO		
HND3	manual operation relay 3	AUTO		
HND4	manual operation relay 4	AUTO		
HND5	manual operation relay 5	AUTO		
HND6	manual operation relay 6	AUTO		
LANG	language	dE		dE = German En = English It = Italian Fr = French
PROG	program number	xx.xx		
VERS	version number	x.xx		

Information on priority logic can be found on page 115.

## System Arrangement 12

### System description:

The controller compares the temperature at sensor S1 to the temperatures at sensors S2 and S3. If the measured temperature differences are higher than the adjusted switch-on temperature differences, the pump (P1) will be activated and the corresponding store zone will be loaded up to the adjusted maximum temperature at most via the valve (V1).

The priority logic causes priority loading of the upper zone of the store.

Domestic hot water afterheating (P2) can be carried out via a thermostat function (S3).

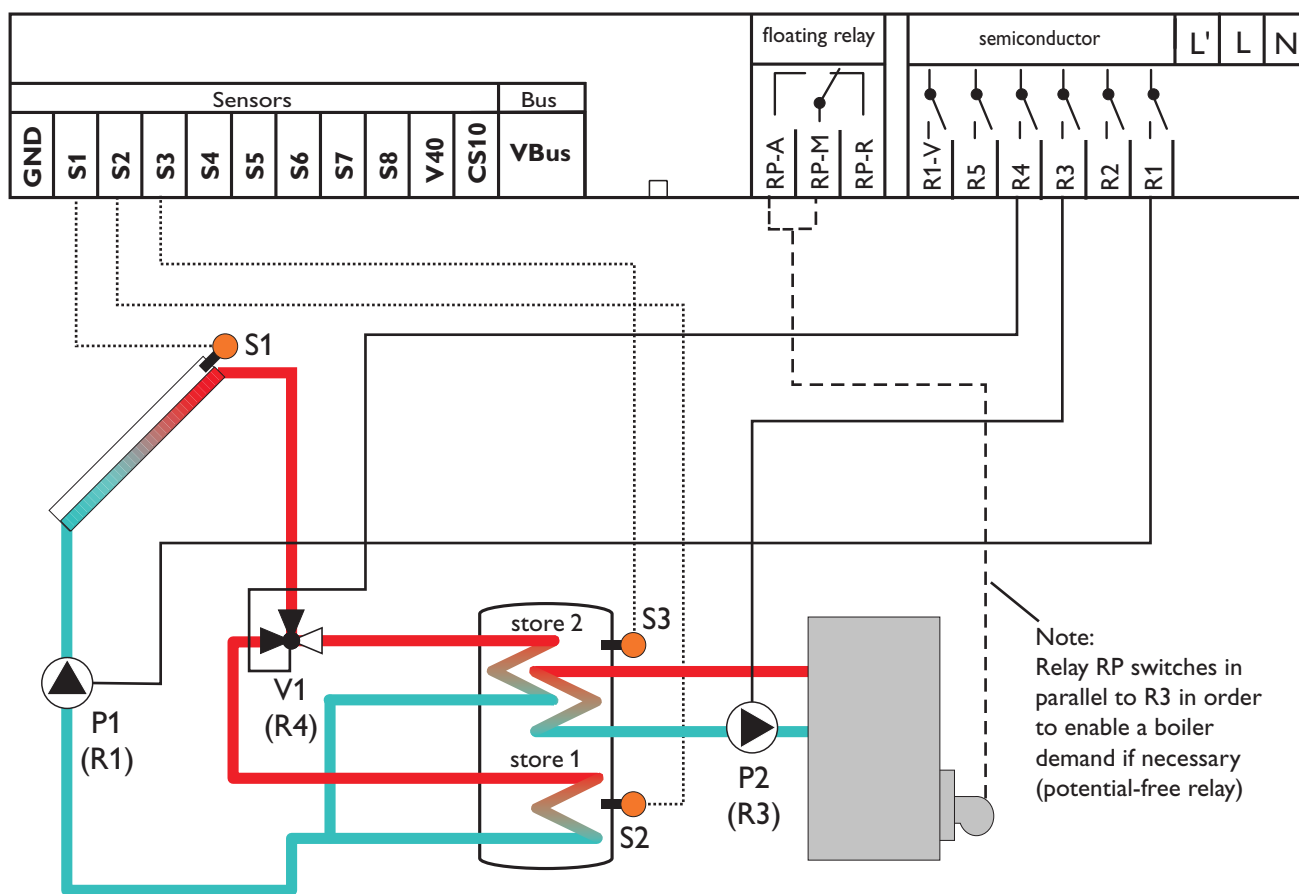

Note: 3-port valve V1 normally open store base

Relay output	Note
R1	solar pump (P1) with speed control
R2	
R3	pump domestic hot water afterheating (P2)
R4	3-port valve (V1) store top/base
R5	
RP-R	
RP-M	boiler demand (potential-free), is switched on in parallel to R3
RP-A	

Sensor input	description
S1	temperature collector
S2	temperature store base
S3	temperature store top
CS10 (optional)	irradiation

channel	description	factory setting	change to	note
COL	temperature collector	-----		
TSTL	temperature store base	-----		
TSTU	temperature store 1 top	-----		
IRR	irradiation	-----		
n %	speed relay	-----		
h P	operating hours relay	-----		
h P3	operating hours relay 3	-----		
TIME	time	-----		Adjust the actual clock time.
Arr	arrangement choice	1	12	Arrangement 12: Multi-layer-store system with domestic hot water afterheating
DT1O	switch-on temperature difference 1	6.0 K		Adjust the desired switch-on temperature difference for store 1.
DT1F	switch-off temperature difference 1	4.0 K		Adjust the desired switch-off temperature difference for store 1.
DT1S	set temperature difference 1	10.0 K		Adjust the desired set temperature difference for store 1.
RIS1	rise 1	2 K		If the adjusted temperature difference DT1S is reached and if the temperature increases by the difference RIS1, the speed will be increased by 10% respectively.
S1MX	maximum temperature store 1	60 °C		Adjust the desired maximum store temperature for store 1.
DT2O	switch-on temperature difference 2	6.0 K		Adjust the desired switch-on temperature difference for store 2.
DT2F	switch-off temperature difference 2	4.0 K		Adjust the desired switch-off temperature difference for store 2.
DT2S	set temperature difference 2	10.0 K		Adjust the desired set temperature difference for store 2.
RIS2	rise 2	2 K		If the adjusted temperature difference DT2S is reached and if the temperature increases by the difference RIS2, the speed will be increased by 10% respectively.
S2MX	maximum temperature store 2	60 °C		Adjust the desired maximum store temperature for store 2.
EM	collector emergency temperature	140 °C		Adjust this value to 200°C when the collector emergency shutdown function should not start.
OCX	Option collector cooling	OFF		
OCN	Option minimum limitation	OFF		
OCF	Option frost protection	OFF		
PRIO	priority	2		priority store top
tST	break time	2 Min.		The loading break time for the priority logic function can be changed (see appendix priority logic)
tRUN	runtime	15 Min.		The oscillating loading time for the priority logic function can be changed (see appendix priority logic)
OREC	option recooling	OFF		
OTC	option tube collector	OFF		

channel	description	factory setting	change to	Note
NH O	switch-on temperature thermostat 1	40.0 °C		Adjust the desired switch-on temperature difference for heat exchange control
NH F	switch-off temperature thermostat 1	45.0 °C		Adjust the desired switch-off temperature difference for heat exchange control
t1 O	time frame 1 switch-on temperature	00:00		Up to 3 additional time frames can be selected for the thermostat function (DHW afterheating). The thermostat function (DHW afterheating) will be activated within these time frames only. Example: If the thermostat function should run from 06:00 a.m. and 08:00 a.m.; and 06:00 p.m. and 07:00 p.m. only, adjust t1O to 06:00 a.m., t1F to 08:00 a.m., t2O to 06:00 p.m. and t2F to 07:00 p.m.. When all time frames are set to 00:00, the thermostat function (DHW afterheating) is always activated (factory setting).
t1 F	time frame 1 switch-off temperature	00:00		
t2 O	time frame 2 switch-on temperature	00:00		
t2 F	time frame 2 switch-off temperature	00:00		
t3 O	time frame 3 switch-on temperature	00:00		
t3 F	time frame 3 switch-off temperature	00:00		
OHQM	option heat quantity measurement	OFF		
CS 10	solar irradiation sensor	5		
n MN	minimum speed relay 1	30		
HND1	manual operation relay 1	AUTO		
HND2	manual operation relay 2	AUTO		
HND3	manual operation relay 3	AUTO		
HND4	manual operation relay 4	AUTO		
HND5	manual operation relay 5	AUTO		
HND6	manual operation relay 6	AUTO		
LANG	language	dE		dE = German En = English It = Italian Fr = French
PROG	program number	xx.xx		
VERS	version number	x.xx		

Information on priority logic can be found on page 115.

## System Arrangement 13

### System description:

The controller compares the temperature at sensor S1 to the temperatures at sensors S2 and S3. If the measured temperature differences are higher than the adjusted switch-on temperature differences, the pump (P1) will be activated and the corresponding store zone will be loaded up to the adjusted maximum temperature at most via the valve (V1).

The priority logic causes priority loading of the upper zone of the store.

Via another temperature differential function (S3/S4), after-heating of the store can be carried out with a solid fuel boiler (P2).

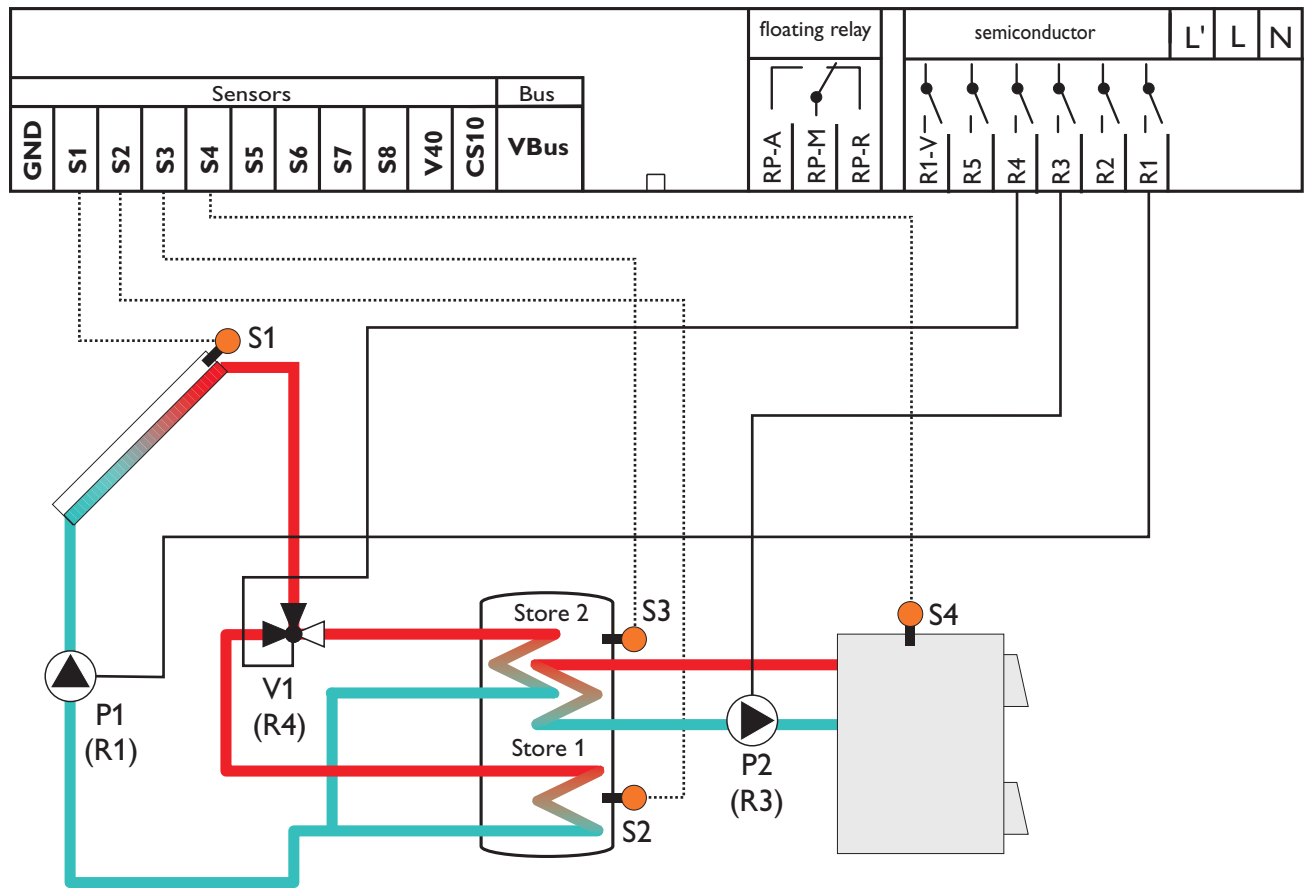

Note: 3-port valve V1 normally open - store base

Relay output	Note
R1	solar pump (P1) with speed control
R2	
R3	pump solid fuel boiler (P2) speed-controlled
R4	3-port valve (V1) store top/base
R5	
RP-R	
RP-M	
RP-A	

Sensor input	description
S1	temperature collector
S2	temperature store base
S3	temperature store top
S4	temperature solid fuel boiler
CS10 (optional)	irradiation

channel	description	factory setting	change to	note
COL	temperature collector	-----		
TSTL	temperature store base	-----		
TSTU	temperature store 1 top	-----		
TSFB	temperature solid fuel boiler	-----		
IRR	irradiation	-----		
n1 %	speed relay 1	-----		
n3 %	speed relay 3	-----		
h P1	operating hours relay 1	-----		
h P3	operating hours relay 3	-----		
TIME	time	-----		Adjust the actual clock time.
Arr	arrangement choice	1	13	Arrangement 13: Multi-layer store system with afterheating with solid fuel boiler
DT1O	switch-on temperature difference 1	6.0 K		Adjust the desired switch-on temperature difference for store 1.
DT1F	switch-off temperature difference 1	4.0 K		Adjust the desired switch-off temperature difference for store 1.
DT1S	set temperature difference 1	10.0 K		Adjust the desired set temperature difference for store 1.
RIS1	rise 1	2 K		If the adjusted temperature difference DT1S is reached and if the temperature increases by the difference RIS1, the speed will be increased by 10% respectively.
S1MX	maximum temperature store 1	60		Adjust the desired maximum store temperature for store 1.
DT2O	switch-on temperature difference 2	6.0 K		Adjust the desired switch-on temperature difference for store 2.
DT2F	switch-off temperature difference 2	4.0 K		Adjust the desired switch-off temperature difference for store 2.
DT2S	set temperature difference 2	10.0 K		Adjust the desired set temperature difference for store 2.
RIS2	rise 2	2 K		If the adjusted temperature difference DT2S is reached and if the temperature increases by the difference RIS2, the speed will be increased by 10% respectively.
S2MX	maximum temperature store 2	60 °C		Adjust the desired maximum store temperature for store 2.
EM	collector emergency temperature	140 °C		Adjust this value to 200°C when the collector emergency shutdown function should not start.
OCX	Option collector cooling	OFF		
OCN	Option minimum limitation	OFF		
OCF	Option frost protection	OFF		
PRIO	priority	2		priority store top
tST	break time	2 Min.		The loading break time for the priority logic function can be changed (see appendix priority logic)
tRUN	runtime	15 Min.		The oscillating loading time for the priority logic function can be changed (see appendix priority logic)
OREC	option recooling	OFF		



channel	description	factory setting	change to	note
OTC	option tube collector	OFF		
DT3O	switch-on temperature difference 3	6.0 K		Adjust the desired switch-on temperature difference for solid fuel boiler pump
DT3F	switch-off temperature difference 3	4.0 K		Adjust the desired switch-off temperature difference for solid fuel boiler pump
DT3S	set temperature DT3	10.0 K		Adjust the desired set temperature difference for solid fuel boiler pump
RIS3	rise DT3	2 K		If the adjusted temperature difference DT3S is reached and if the temperature increases by the difference RIS3, speed relay 3 will be increased by 10% respectively.
MX3O	switch-on threshold for maximum temperature	60,0 °C		Adjust the desired maximum store temperature for switching off the solid fuel burner pump (P2). Note: If the maximum store temperature (MX3O) at sensor S3 is reached, pump P2 is switched off. When the store temperature falls below MX3F at S3, the pump is switched-on again.
MX3F	switch-off threshold for maximum temperature	58.0 °C		
MN3O	switch-on threshold for minimum temperature	60,0 °C		Adjust the desired minimum temperature for releasing pump P2. Note: Pump P2 is switched on when the solid fuel boiler (S4) reaches 65 °C (MN3F) and when there is a temperature difference (DT3O) to store sensor S3. It is switched off when the temperature of the solid fuel boiler falls to 60 °C (MN3O), the temperature difference falls below the switch-off temperature difference (DT3F) or when the maximum store temperature (MX3O) at sensor S3 is reached.
MN3F	switch-off threshold for minimum temperature	65.0 °C		
OHQM	option heat quantity measurement	OFF		
CS 10	solar irradiation sensor	5		
n1MN	minimum speed relay 1	30		
n3MN	minimum speed relay 3	30		
HND1	manual operation relay 1	AUTO		
HND2	manual operation relay 2	AUTO		
HND3	manual operation relay 3	AUTO		
HND4	manual operation relay 4	AUTO		
HND5	manual operation relay 5	AUTO		
HND6	manual operation relay 6	AUTO		
LANG	language	dE		dE = German En = English It = Italian Fr = French
PROG	program number	xx.xx		
VERS	version number	x.xx		

Information on priority logic can be found on page 115.

## System Arrangement 14

### System description:

The controller compares the temperature at sensor S1 to the temperatures at sensors S2 and S3. If the measured temperature differences are higher than the adjusted switch-on temperature differences, the pump (P1) will be activated and the corresponding store zone will be loaded up to the adjusted maximum temperature at most via the valve (V1).

The priority logic causes priority loading of the upper zone of the store.

Via another temperature differential function (S3 heat source / S5 heat sink) heating circuit return preheating (heating circuit backup) is possible via V2.

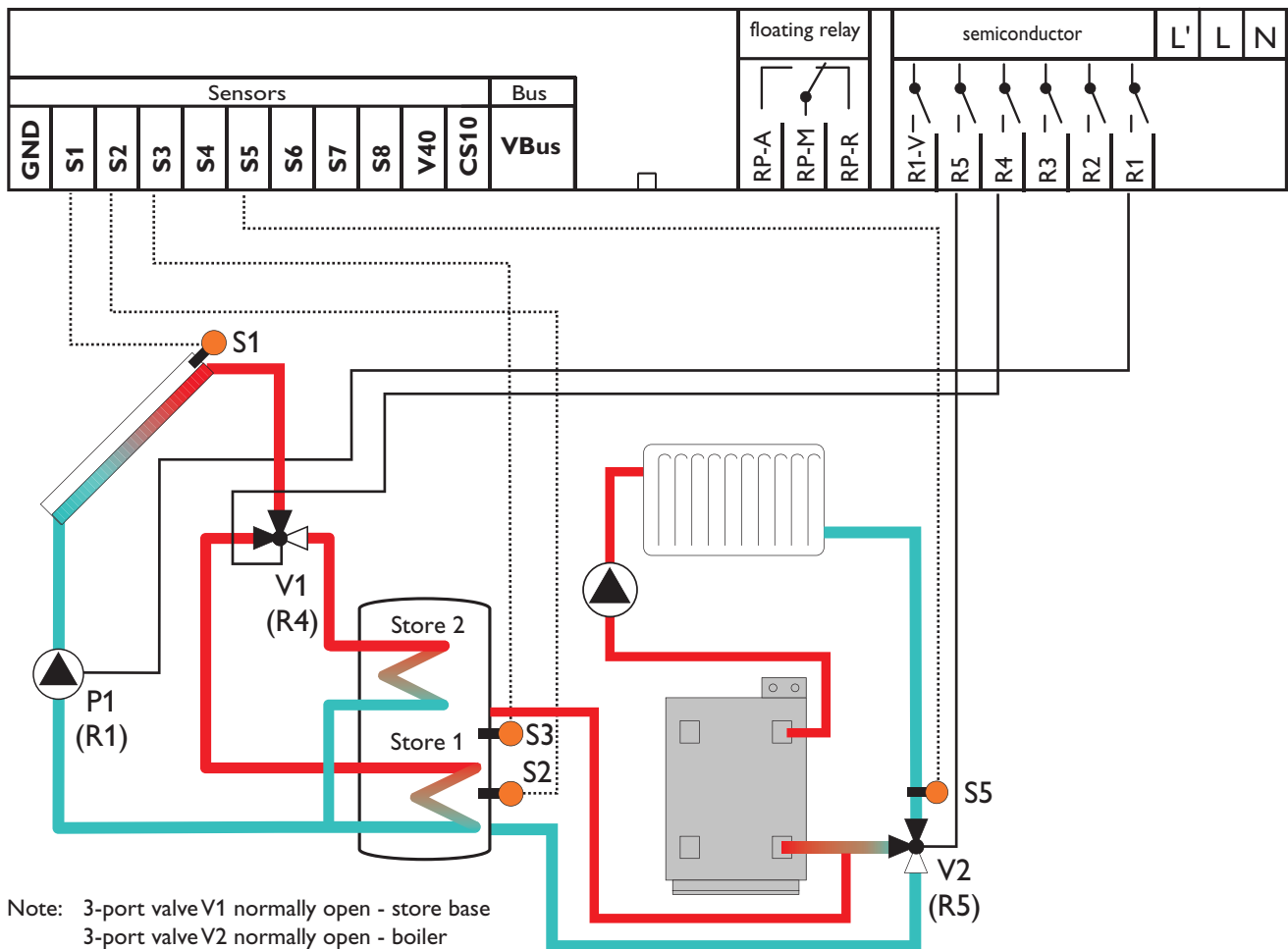

Relay output	Note
R1	solar pump (P1) with speed control
R2	
R3	
R4	3-port valve (V1) store top/base
R5	3-port valve (V2) heating circuit return preheating
RP-R	
RP-M	
RP-A	

Sensor input	description
S1	temperature collector
S2	temperature store base
S3	temperature store top
S5	temperature heating circuit
CS10 (optional)	irradiation

channel	description	factory setting	change to	note
COL	temperature collector	-----		
TSTL	temperature store base	-----		
TSTU	temperature store 1 top	-----		
TREC	temperature heating circuit	-----		
IRR	irradiation	-----		
n %	speed relay	-----		
h P	operating hours relay	-----		
TIME	time	-----		Adjust the actual clock time.
Arr	arrangement choice	1	14	Arrangement 14: Multi-layer store system with heating circuit return preheating
DT1O	switch-on temperature difference 1	6.0 K		Adjust the desired switch-on temperature difference for store 1.
DT1F	switch-off temperature difference 1	4.0 K		Adjust the desired switch-off temperature difference for store 1.
DT1S	set temperature difference 1	10.0 K		Adjust the desired set temperature for store 1
RIS1	rise 1	2 K		If the adjusted temperature difference DT1S is reached and if the temperature increases by the difference RIS1, the speed will be increased by 10% respectively.
S1MX	maximum temperature store 1	60 °C		Adjust the desired maximum store temperature for store 1.
DT2O	switch-on temperature difference 2	6.0 K		Adjust the desired switch-on temperature difference for store 2.
DT2F	switch-off temperature difference 2	4.0 K		Adjust the desired switch-off temperature difference for store 2.
DT2S	set temperature difference 2	10.0 K		Adjust the desired set temperature difference for store 2.
RIS2	rise 2	2 K		If the adjusted temperature difference DT2S is reached and if the temperature increases by the difference RIS2, the speed will be increased by 10% respectively.
S2MX	maximum temperature store 2	60 °C		Adjust the desired maximum store temperature for store 2.
EM	collector emergency temperature	140 °C		Adjust this value to 200°C when the collector emergency shutdown function should not start.
OCX	Option collector cooling	OFF		
OCN	Option minimum limitation	OFF		
OCF	Option frost protection	OFF		
PRIO	priority	2		priority store top
tST	break time	2 Min.		The loading break time for the priority logic function can be changed (see appendix priority logic)
tRUN	runtime	15 Min.		The oscillating loading time for the priority logic function can be changed (see appendix priority logic)
OREC	option recooling	OFF		
OTC	option tube collector	OFF		
DT3O	switch-on temperature difference 3	6.0 K		Adjust the desired switch-on temperature difference for heating circuit return preheating (heating circuit backup)

channel	description	factory setting	change to	note
DT3F	switch-off temperature difference 3	4.0 K		Adjust the desired switch-off temperature difference for heating circuit return preheating (heating circuit backup)
OHQM	option heat quantity measurement	OFF		
CS 10	solar irradiation sensor	5		
n MN	minimum speed relay 1	30		
HND1	manual operation relay 1	AUTO		
HND2	manual operation relay 2	AUTO		
HND3	manual operation relay 3	AUTO		
HND4	manual operation relay 4	AUTO		
HND5	manual operation relay 5	AUTO		
HND6	manual operation relay 6	AUTO		
LANG	language	dE		dE = German En = English It = Italian Fr = French
PROG	program number	xx.xx		
VERS	version number	x.xx		

Information on priority logic can be found on page 115.

## System Arrangement 15

### System description:

The controller compares the temperature at sensor S1 to the temperatures at sensors S2 and S3. If the measured temperature differences are higher than the adjusted switch-on temperature differences, the pump (P1) will be activated and the corresponding store zone will be loaded up to the adjusted maximum temperature at most via the valve (V1).

The priority logic causes priority loading of the upper zone of the store.

Via another temperature differential function (S3 heat source / S5 heat sink) heating circuit return preheating is possible via V2. Domestic hot water afterheating (P2) can be carried out via a thermostat function (S3).

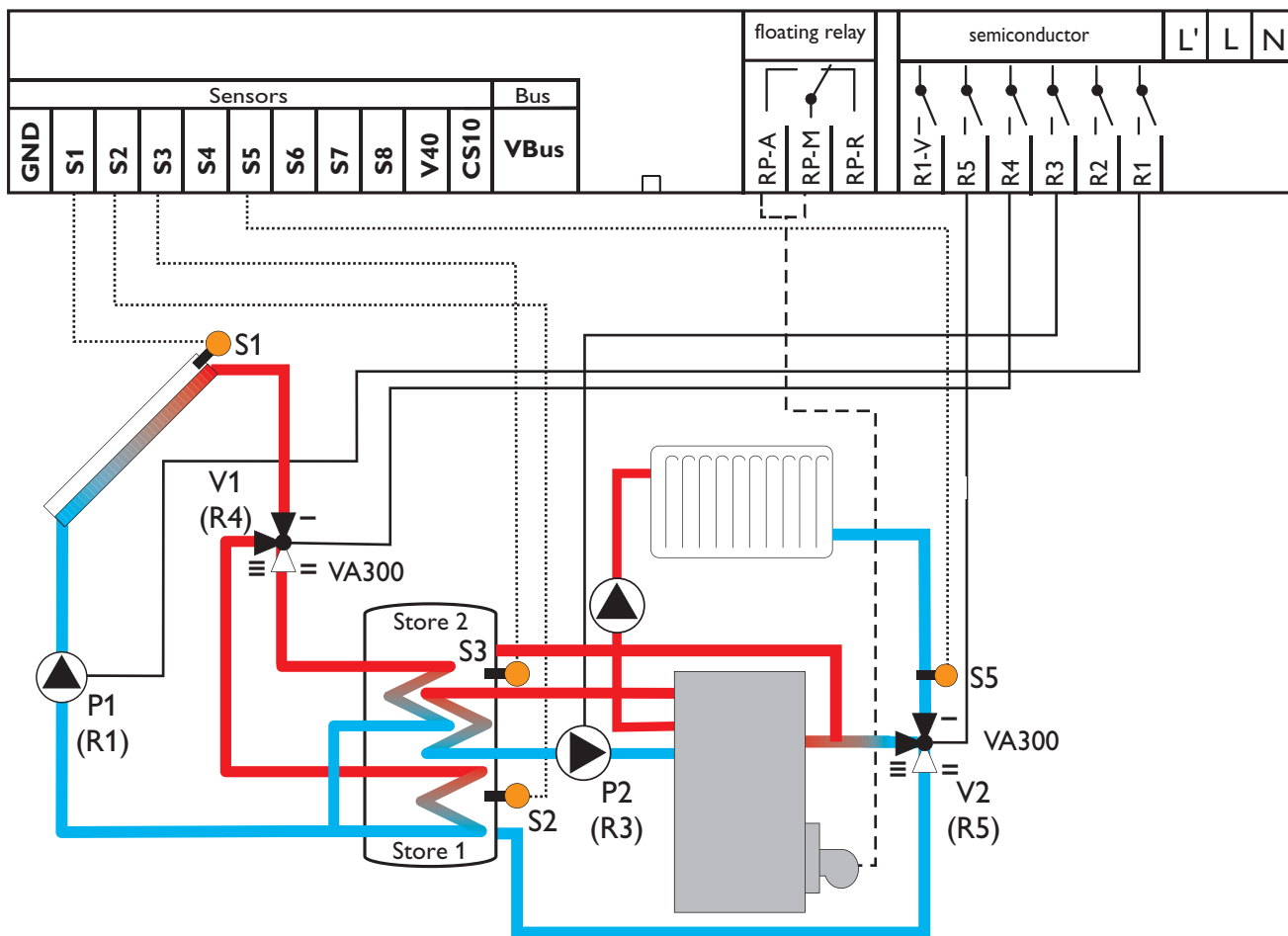

Note: 3-port valve V1 normally open - store base  
3-port valve V2 normally open - boiler

Relay output	Note
R1	solar pump (P1) with speed control
R2	
R3	domestic hot water afterheating pump (P2)
R4	3-port valve (V1) store top/base
R5	3-port valve (V2) heating circuit return preheating
RP-R	
RP-M	boiler demand (potential-free), is switched on in parallel to R3
RP-A	

Sensor input	description
S1	temperature collector
S2	temperature store base
S3	temperature store top
S5	temperature heating circuit
CS10 (optional)	irradiation

channel	description	factory setting	change to	note
COL	temperature collector	-----		
TSTL	temperature store base	-----		
TSTU	temperature store 1 top	-----		
TREC	temperature heating circuit	-----		
IRR	irradiation	-----		
n %	speed relay	-----		
h P	operating hours relay	-----		
h P3	operating hours relay 3	-----		
TIME	time	-----		Adjust the actual clock time.
Arr	arrangement choice	1	15	Arrangement 15: Multi-layer store system with heating circuit return preheating and DHW afterheating
DT1O	switch-on temperature difference 1	6.0 K		Adjust the desired switch-on temperature difference for store 1.
DT1F	switch-off temperature difference 1	4.0 K		Adjust the desired switch-off temperature difference for store 1.
DT1S	set temperature difference 1	10.0 K		Adjust the desired set temperature difference for store 1.
RIS1	rise 1	2 K		If the adjusted temperature difference DT1S is reached and if the temperature increases by the difference RIS1, the speed will be increased by 10% respectively.
S1MX	maximum temperature store 1	60 °C		Adjust the desired maximum store temperature for store 1.
DT2O	switch-on temperature difference 2	6.0 K		Adjust the desired switch-on temperature difference for store 2.
DT2F	switch-off temperature difference 2	4.0 K		Adjust the desired switch-off temperature difference for store 2.
DT2S	set temperature difference 2	10.0 K		Adjust the desired set temperature difference for store 2.
RIS2	rise 2	2 K		If the adjusted temperature difference DT2S is reached and if the temperature increases by the difference RIS2, the speed will be increased by 10% respectively.
S2MX	maximum temperature store 2	60 °C		Adjust the desired maximum store temperature for store 2.
EM	collector emergency temperature	140 °C		Adjust this value to 200°C when the collector emergency shutdown function should not start.
OCX	Option collector cooling	OFF		
OCN	Option minimum limitation	OFF		
OCF	Option frost protection	OFF		
PRIO	priority	2		priority store top
tST	break time	2 Min.		The loading break time for the priority logic function can be changed (see appendix priority logic)
tRUN	runtime	15 Min.		The oscillating loading time for the priority logic function can be changed (see appendix priority logic)
OREC	option recooling	OFF		

channel	description	factory setting	change to	note
OTC	option tube collector	OFF		
DT3O	switch-on temperature difference 3	6.0 K		Adjust the desired switch-on temperature difference for heating circuit return preheating (heating circuit backup)
DT3F	switch-off temperature difference 3	4.0 K		Adjust the desired switch-off temperature difference for heating circuit return preheating (heating circuit backup)
NH O	switch-on temperature thermostat 1	40.0 °C		Adjust the desired switch-on temperature difference for domestic hot water afterheating
NH F	switch-off temperature thermostat 1	45.0 °C		Adjust the desired switch-off temperature difference for domestic hot water afterheating
t1 O	time frame 1 switch-on temperature	00:00		Up to 3 additional time frames can be selected for the thermostat function (DHW afterheating). The thermostat function (DHW afterheating) will be activated within these time frames only. Example: If the thermostat function (DHW afterheating) should run between 06:00 a.m. and 08:00 a.m.; and 06:00 p.m. and 07:00 p.m., adjust t1 O to 06:00 a.m., t1 F to 08:00 a.m., t2 O to 06:00 p.m. and t2 F to 07:00 p.m.. When all time frames are set to 00:00, the thermostat function (DHW afterheating) is always activated (factory setting).
t1 F	time frame 1 switch-off temperature	00:00		
t2 O	time frame 2 switch-on temperature	00:00		
t2 F	time frame 2 switch-off temperature	00:00		
t3 O	time frame 3 switch-on temperature	00:00		
t3 F	time frame 3 switch-off temperature	00:00		
OHQM	option heat quantity measurement	OFF		
CS 10	solar irradiation sensor	5		
n MN	minimum speed relay 1	30		
HND1	manual operation relay 1	AUTO		
HND2	manual operation relay 2	AUTO		
HND3	manual operation relay 3	AUTO		
HND4	manual operation relay 4	AUTO		
HND5	manual operation relay 5	AUTO		
HND6	manual operation relay 6	AUTO		
LANG	language	dE		dE = German En = English It = Italian Fr = French
PROG	program number	xx.xx		
VERS	version number	x.xx		

Information on priority logic can be found on page 115.

## System Arrangement 16

### System description:

The controller compares the temperature at sensor S1 to the temperatures at sensors S2 and S4. If the measured temperature differences are higher than the adjusted switch-on temperature differences, the pump (P1) will be activated and the corresponding store will be loaded up to the adjusted

maximum temperature at most via the valve (V1). Heat transfer control to store 2 (P2) can be carried out via another temperature differential function (S3 heat source/ S4 heat sink).

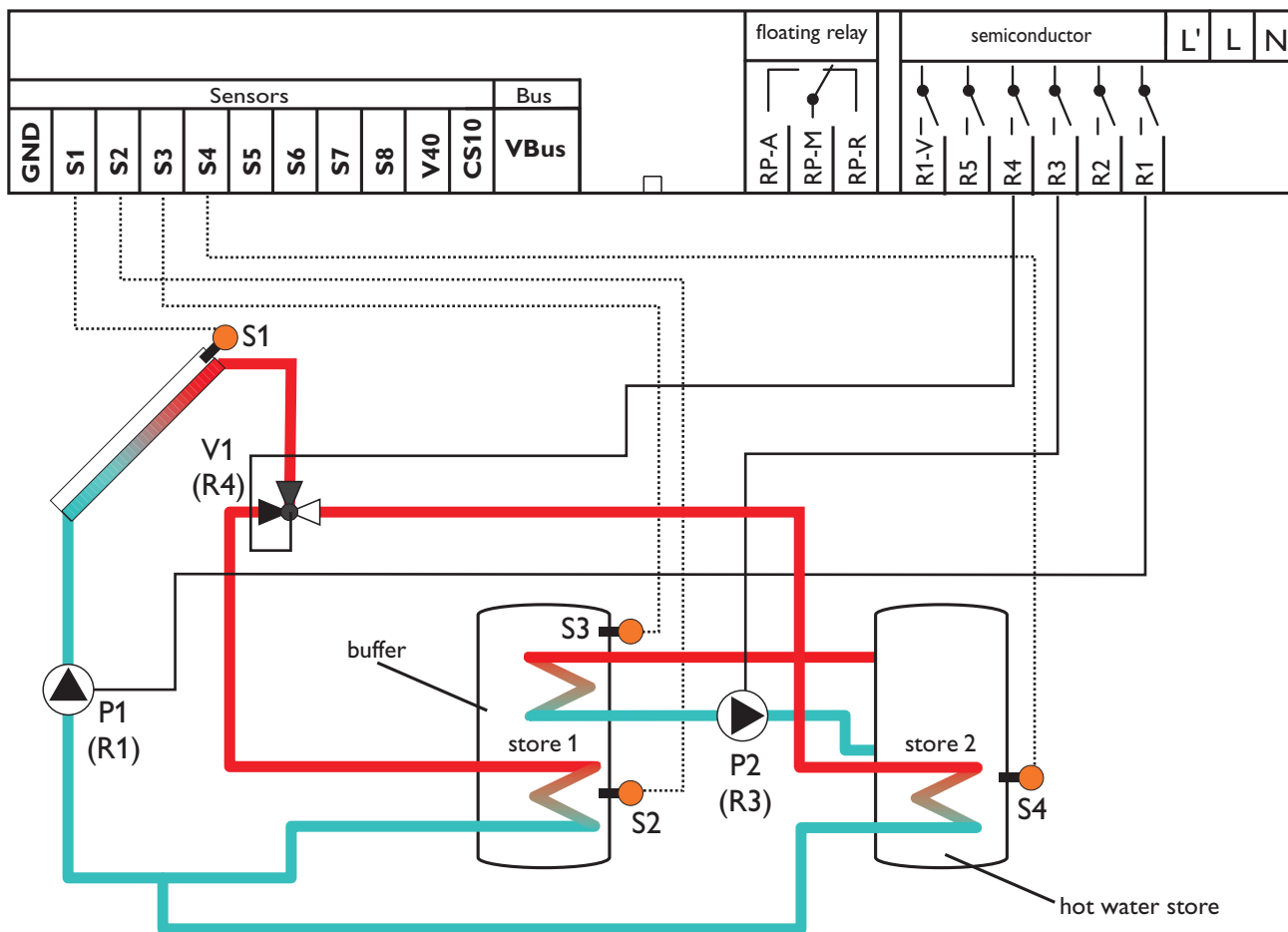

Note: 3-port valve V1 normally open - store 1

Relay output	Note
R1	solar pump (P1) with speed control
R2	
R3	pump heat exchange (P2)
R4	3-port valve (V1) store top/base
R5	
RP-R	
RP-M	
RP-A	

Sensor input	description
S1	temperature collector
S2	temperature store 1 base
S3	temperature store 1 top
S4	temperature store 2 base
CS10 (optional)	irradiation



channel	description	factory setting	change to	note
COL	temperature collector	-----		
TST1	temperature store 1 base	-----		
TSTU	temperature store 1 top	-----		
TST2	temperature store 2 base	-----		
IRR	irradiation	-----		
n1 %	speed relay 1	-----		
n3 %	speed relay 3	-----		
h P1	operating hours relay 1	-----		
h P3	operating hours relay 3	-----		
TIME	time	-----		Adjust the actual clock time.
Arr	arrangement choice	1	16	Arrangement 16: 2-store system with heat ex-change control
DT1O	switch-on temperature difference 1	6.0 K		Adjust the desired switch-on temperature difference for store 1.
DT1F	switch-off temperature difference 1	4.0 K		Adjust the desired switch-off temperature difference for store 1.
DT1S	set temperature difference 1	10.0 K		Adjust the desired set temperature difference for store 1.
RIS1	rise 1	2 K		If the adjusted temperature difference DT1S is reached and if the temperature increases by the difference RIS1, the speed will be increased by 10% respectively.
S1MX	maximum temperature store 1	60 °C		Adjust the desired maximum store temperature for store 1.
DT2O	switch-on temperature difference 2	6.0 K		Adjust the desired switch-on temperature difference for store 2.
DT2F	switch-off temperature difference 2	4.0 K		Adjust the desired switch-off temperature difference for store 2.
DT2S	set temperature difference 2	10.0 K		Adjust the desired set temperature difference for store 2
RIS2	rise 2	2 K		If the adjusted temperature difference DT2S is reached and if the temperature increases by the difference RIS2, the speed will be increased by 10% respectively.
S2MX	maximum temperature store 2	60 °C		Adjust the desired maximum store temperature for store 2.
EM	collector emergency temperature	140 °C		Adjust this value to 200°C when the collector emergency shutdown function should not start.
OCX	Option collector cooling	OFF		
OCN	Option minimum limitation	OFF		
OCF	Option frost protection	OFF		
PRIO	priority	1	2	Priority store 2 (hot water store), subordinate store 1 (buffer store)
tST	break time	2 Min.		The loading break time for the priority logic function can be changed (see appendix priority logic)
tRUN	runtime	15 Min.		The oscillating runtime for the priority logic function can be changed (see appendix priority logic)

channel	description	factory setting	change to	note
OREC	option recooling	OFF		
OTC	option tube collector	OFF		
DT3O	switch-on temperature difference 3	6.0 K		Adjust the desired switch-on temperature difference for heat exchange control
DT3F	switch-off temperature difference 3	4.0 K		Adjust the desired switch-off temperature difference for heat exchange control
DT3S	set temperature DT3	10.0 K		Adjust the desired set temperature difference for heat exchange control
RIS3	rise DT3	2 K		If the adjusted temperature difference DT3S is reached and if the temperature increases by the difference RIS3, speed relay 3 (P2) will be increased by 10% respectively.
MX3O	switch-on threshold for maximum temperature	60,0		Adjust the desired maximum store temperature for the hot water store (referred to P2). Note: If the maximum store temperature (MX3O) at sensor S4 is reached, pump P2 is switched off. If the store temperature falls below MX3F at S4, the pump is switched-on again.
MX3F	switch-off threshold for maximum temperature	58.0 °C		
MN3O	switch-on threshold for minimum temperature	5,0		A minimum temperature for releasing pump P2 can be adjusted. Example: If pump P2 should be released at a temperature identical to or higher than 60 °C in the buffer store (measured at S3), the following values have to be adjusted: MN3O = 55 °C, MN3F = 60 °C. The pump will then be released if 60 °C has been reached and will be blocked again if the temperature falls below 55 °C.
MN3F	switch-off threshold for minimum temperature	10.0 °C		
OHQM	option heat quantity measurement	OFF		
CS 10	solar irradiation sensor	5		
n1MN	minimum speed relay 1	30		
n3MN	minimum speed relay 3	30		
HND1	manual operation relay 1	AUTO		
HND2	manual operation relay 2	AUTO		
HND3	manual operation relay 3	AUTO		
HND4	manual operation relay 4	AUTO		
HND5	manual operation relay 5	AUTO		
HND6	manual operation relay 6	AUTO		
LANG	language	dE		dE = German En = English It = Italian Fr = French
PROG	program number	xx.xx		
VERS	version number	x.xx		

Information on priority logic can be found on page 115.

## System Arrangement 17

### System description:

The controller compares the temperature at sensor S1 to the temperatures at sensors S2 and S4. If the measured temperature differences are higher than the adjusted switch-on temperature differences, the pump (P1 or P2) will be activated and the corresponding store will be loaded up to the adjusted maximum temperature at most.

Heat transfer control to store 2 (P3) is possible via another temperature differential function (S3 heat source/S4 heat sink).

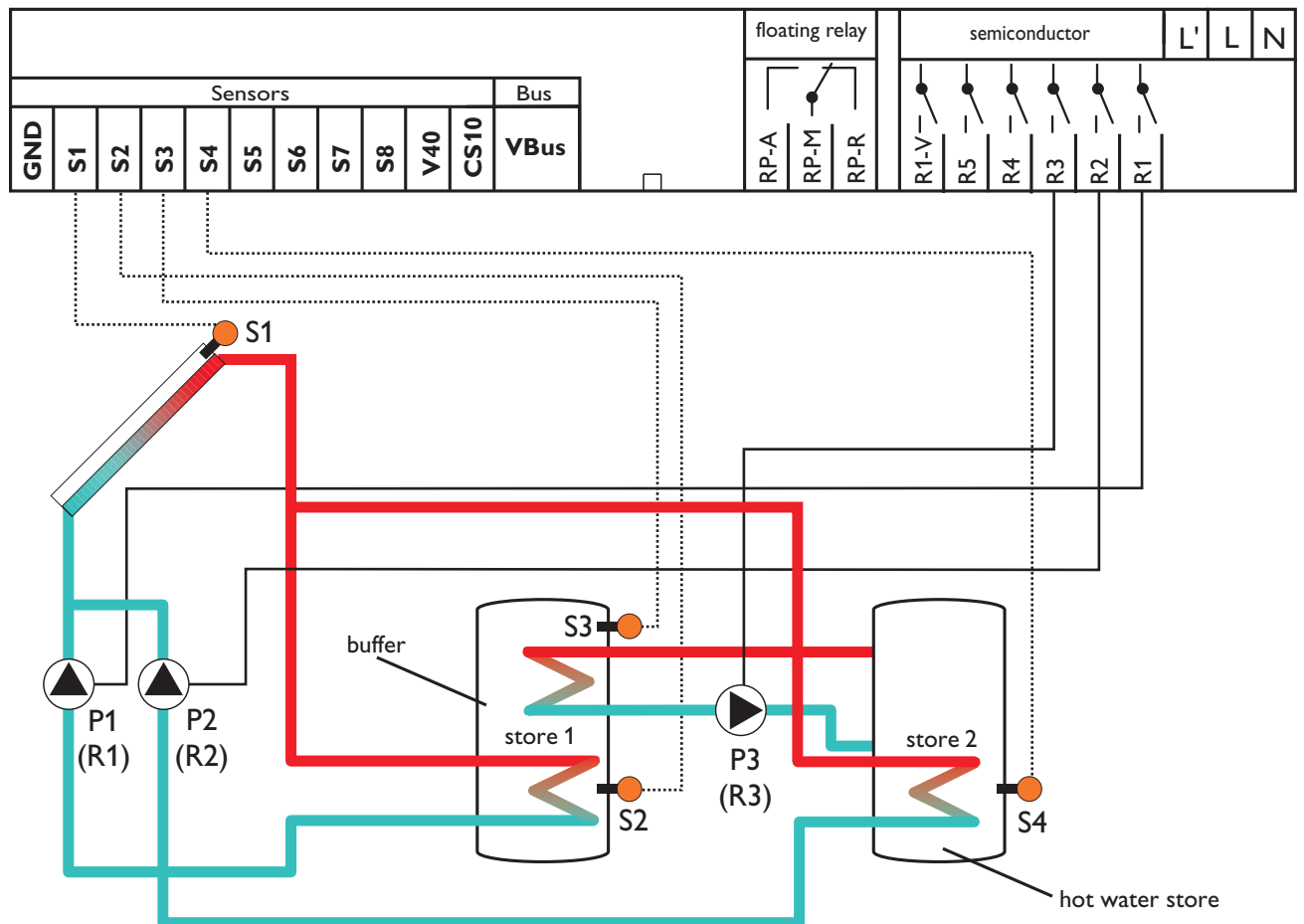

Relay output	Note
R1	solar pump (P1) with speed control
R2	solar pump (P1) with speed control
R3	pump heat exchange (P3)
R4	
R5	
RP-R	
RP-M	
RP-A	

Sensor input	description
S1	temperature collector
S2	temperature store base
S3	temperature store 1 top
S4	temperature store 2 base
CS10 (optional)	irradiation

channel	description	factory setting	change to	note
COL	temperature collector	-----		
TST1	temperature store 1 base	-----		
TSTU	temperature store 1 top	-----		
TST2	temperature store 2 base	-----		
IRR	irradiation	-----		
n1 %	speed relay 1	-----		
n2 %	speed relay 2	-----		
n3 %	speed relay 3	-----		
h P1	operating hours relay 1	-----		
h P2	operating hours relay 2			
h P3	operating hours relay 3	-----		
TIME	time	-----		Adjust the actual clock time.
Arr	arrangement choice	1	17	Arrangement 17: 2-store solar system (pump control) with heat exchange control
DT1O	switch-on temperature difference 1	6.0 K		Adjust the desired switch-on temperature difference for store 1.
DT1F	switch-off temperature difference 1	4.0 K		Adjust the desired switch-off temperature difference for store 1.
DT1S	set temperature difference 1	10.0 K		Adjust the desired set temperature difference for store 1.
RIS1	rise 1	2 K		If the adjusted temperature difference DT1S is reached and if the temperature increases by the difference RIS1, the speed will be increased by 10% respectively.
S1MX	maximum temperature store 1	60 °C		Adjust the desired maximum store temperature for store 1.
DT2O	switch-on temperature difference 2	6.0 K		Adjust the desired switch-on temperature difference for store 2.
DT2F	switch-off temperature difference 2	4.0 K		Adjust the desired switch-off temperature difference for store 2.
DT2S	set temperature difference 2	10.0 K		Adjust the desired set temperature difference for store 2.
RIS2	rise 2	2 K		If the adjusted temperature difference DT2S is reached and if the temperature increases by the difference RIS2, the speed will be increased by 10% respectively.
S2MX	maximum temperature store 2	60 °C		Adjust the desired maximum store temperature for store 2.
EM	collector emergency temperature	140 °C		Adjust this value to 200°C when the collector emergency shutdown function should not start.
OCX	Option collector cooling	OFF		
OCN	Option minimum limitation	OFF		
OCF	Option frost protection	OFF		
PRIO	priority	1	2	Priority store 2 (hot water store), subordinate store 1 (buffer store)
tST	break time	2 Min.		The loading break time for the priority logic function can be changed (see appendix priority logic)
tRUN	runtime	15 Min.		The oscillating loading time for the priority logic function can be changed (see appendix priority logic)

channel	description	factory setting	change to	note
OREC	option recooling	OFF		
OTC	option tube collector	OFF		
DT3O	switch-on temperature difference 3	6.0 K		Adjust the desired switch-on temperature difference for heat exchange control
DT3F	switch-off temperature difference 3	4.0 K		Adjust the desired switch-off temperature difference for heat exchange control
DT3S	set temperature DT3	10.0 K		Adjust the desired set temperature difference for heat exchange control
RIS3	rise DT3	2 K		If the adjusted temperature difference DT3S is reached and if the temperature increases by the difference RIS3, the speed relay 3 (P3) will be increased by 10% respectively.
MX3O	switch-on threshold for maximum temperature	60,0 °C		Adjust the desired maximum store temperature for the hot water store (referred to P3). Note: If the maximum store temperature (MX3O) at sensor S4 is reached, pump P3 is switched off. If the store temperature falls below MX3F at S4, the pump is switched-on again.
MX3F	switch-off threshold for maximum temperature	58.0 °C		
MN3O	switch-on threshold for minimum temperature	5,0 °C		A minimum temperature for releasing pump P3 can be adjusted. Example: If pump P3 should switch on e.g. at a temperature of 60 °C in the buffer store (measured at S3), adjust the following values: MN3O = 55 °C, MN3F = 60 °C. The pump will then be switched on again, if the temperature of 60 °C is reached. It will be blocked if the temperature falls below 55 °C.
MN3F	switch-off threshold for minimum temperature	10.0 °C		
OHQM	option heat quantity measurement	OFF		
CS 10	solar irradiation sensor	5		
n1MN	minimum speed relay 1	30		
n3MN	minimum speed relay 3	30		
HND1	manual operation relay 1	AUTO		
HND2	manual operation relay 2	AUTO		
HND3	manual operation relay 3	AUTO		
HND4	manual operation relay 4	AUTO		
HND5	manual operation relay 5	AUTO		
HND6	manual operation relay 6	AUTO		
LANG	language	dE		dE = German En = English It = Italian Fr = French
PROG	program number	xx.xx		
VERS	version number	x.xx		

Information on priority logic can be found on page 115.

## System Arrangement 18

### System description:

The controller compares the temperatures at the collector sensors S1 and S6 to the store temperature at store sensor S2. If one of the measured temperature differences is higher than the adjusted switch-on temperature differences, the corresponding pump (P1, P2) will be activated and the store will be loaded.

Heat transfer control to an existant store (P3) can be carried out via another temperature differential function (S3 heat source/S4 heat sink).

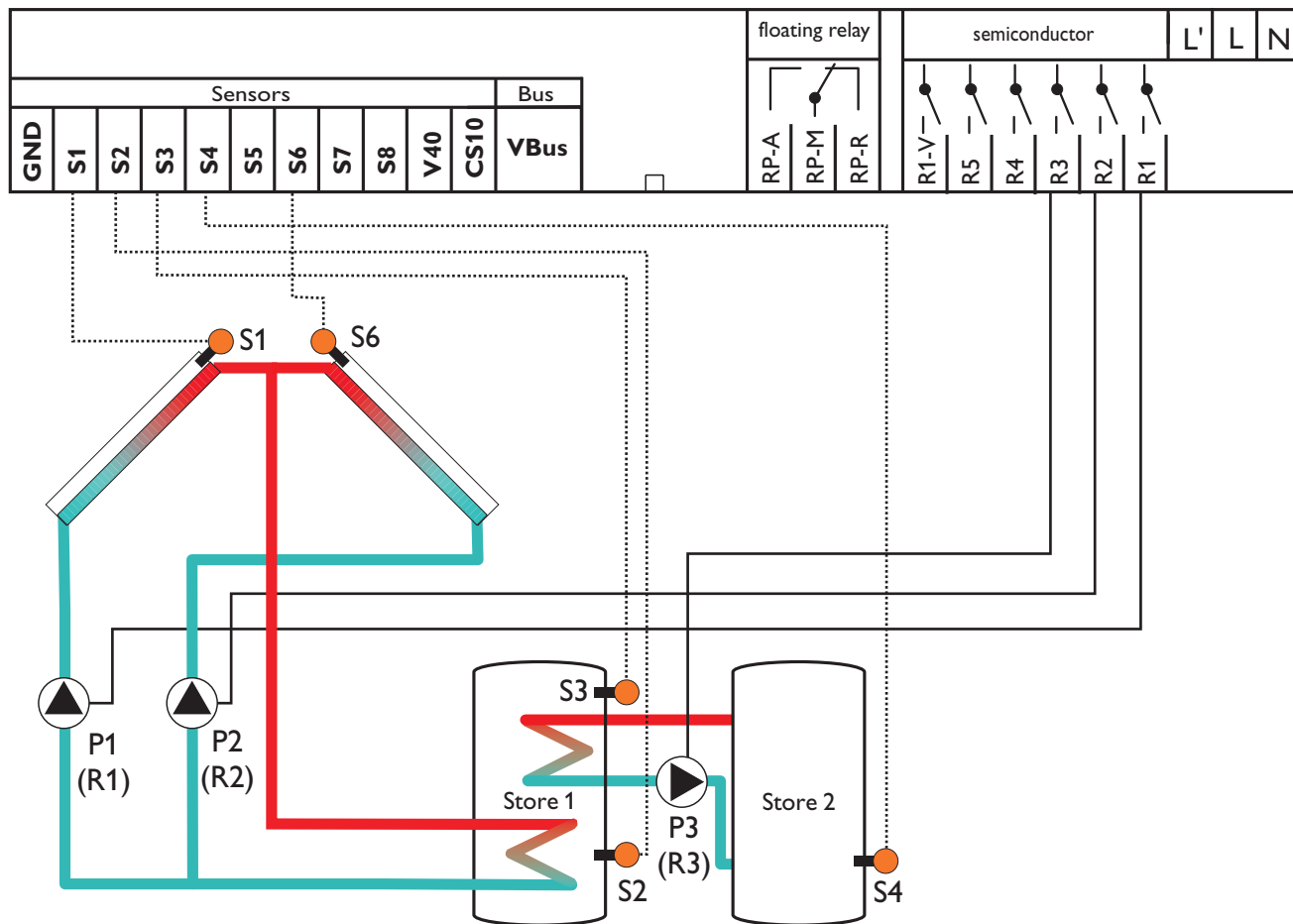

Relay output	Note
R1	solar pump (P1) with speed control
R2	solar pump (P2) with speed control
R3	pump heat exchange (P3)
R4	
R5	
RP-R	
RP-M	
RP-A	

Sensor input	description
S1	temperature collector 1
S2	temperature store 1 base
S3	temperature store 1 top
S4	temperature store 2 base
S6	temperature collector 2
CS10 (optional)	irradiation

channel	description	factory setting	change to	note
COL1	temperature collector 1	-----		
TST1	temperature store 1 base	-----		
TSTU	temperature store 1 top	-----		
TST2	temperature store 2 base	-----		
COL2	temperature collector 2	-----		
IRR	irradiation	-----		
n1 %	speed relay 1	-----		
n2 %	speed relay 2	-----		
n3 %	speed relay 3	-----		
h P1	operating hours relay 1	-----		
h P2	operating hours relay 2	-----		
h P3	operating hours relay 3	-----		
TIME	time	-----		Adjust the actual clock time.
Arr	arrangement choice	1	18	Arrangement 18: 2 collector-system (east-/west collectors) with 1 store and heat exchange control to another store
DT O	switch-on temperature difference	6.0 K		Adjust the desired switch-on temperature difference. Note: This value applies to collector 1 and 2
DT F	switch-off temperature difference	4.0 K		Adjust the desired switch-off temperature difference Note: This value applies to collector 1 and 2
DT S	set temperature difference	10.0 K		Adjust the desired set temperature difference Note: This value applies to collector 1 and 2
RIS	rise	2 K		If the adjusted temperature difference DTS is reached and if the temperature increases by the difference RIS, the speed will be increased by 10% respectively. Note: This value applies to collector 1 and 2
S MX	maximum store temperature	60 °C		Adjust the desired maximum store temperature
EM1	emergency temperature collector 1	140 °C		Adjust this value to 200°C when the collector emergency shutdown function should not start.
OCX1	option collector cooling collector 1	OFF		
OCN1	option minimum limitation collector 1	OFF		
OCF1	option frost protection collector 1	OFF		
EM2	emergency temperature collector 2	140 °C		Adjust this value to 200°C when the collector emergency shutdown function should not start.
OCX2	option collector cooling collector 2	OFF		
OCN2	option minimum limitation collector 2	OFF		
OCF2	option frost protection collector 2	OFF		

channel	description	factory setting	change to	note
OREC	option recooling	OFF		
OTC	option tube collector	OFF		
DT3O	switch-on temperature difference 3	6.0 K		Adjust the desired switch-on temperature difference for heat exchange control
DT3F	switch-off temperature difference 3	4.0 K		Adjust the desired switch-off temperature difference for heat exchange control
DT3S	set temperature DT3	10.0 K		Adjust the desired set temperature difference for heat exchange control
RIS3	rise DT3	2 K		If the adjusted temperature difference DT3S is reached and if the temperature increases by the difference RIS3, speed relay 3 (P3) will be increased by 10% respectively.
MX3O	switch-on threshold for maximum temperature	60,0 °C		Adjust the desired maximum store temperature for the existing store (pump P3). Note: If the maximum store temperature (MX3O) at sensor S4 is reached, pump P3 is switched off. If the store temperature falls below MX3F at S4, the pump is switched-on again.
MX3F	switch-off threshold for maximum temperature	58.0 °C		
MN3O	switch-on threshold for minimum temperature	5,0 °C		A minimum temperature for releasing pump P3 can be adjusted. Note: If pump P3 should be released at a temperature identical to or higher than 60 °C in the solar store (measured at S3), the following values have to be adjusted: MN3O = 55 °C, MN3F = 60 °C. The pump will then be released if 60 °C has been reached and will be blocked again if the temperature falls below 55 °C.
MN3F	switch-off threshold for minimum temperature	10.0 °C		
OHQM	option heat quantity measurement	OFF		
CS 10	solar irradiation sensor	5		
n1MN	minimum speed relay 1	30		
n2MN	minimum speed relay 2	30		
n3MN	minimum speed relay 3	30		
HND1	manual operation relay 1	AUTO		
HND2	manual operation relay 2	AUTO		
HND3	manual operation relay 3	AUTO		
HND4	manual operation relay 4	AUTO		
HND5	manual operation relay 5	AUTO		
HND6	manual operation relay 6	AUTO		
LANG	language	dE		dE = German En = English It = Italian Fr = French
PROG	program number	xx.xx		
VERS	version number	x.xx		



## System Arrangement 19

### System description:

The controller compares the temperatures at the collector sensors S1 and S6 to the store temperature at store sensor S2. If one of the measured temperature differences is higher than the adjusted switch-on temperature differences, the

corresponding pump (P1, P2) will be activated and the store will be loaded.

Domestic hot water afterheating (P3) is possible via a thermostat function (S3).

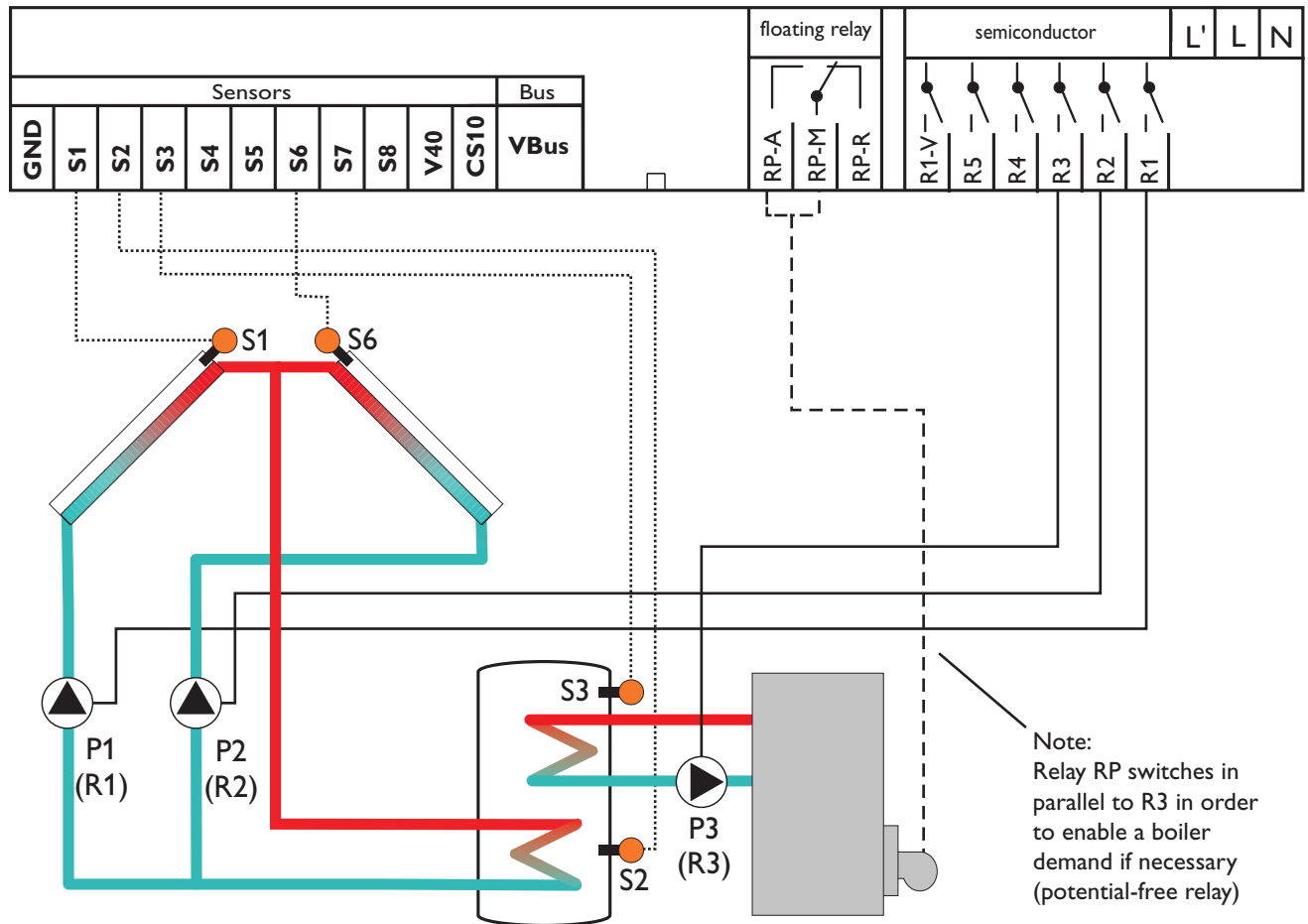

Relay output	Note
R1	solar pump (P1) with speed control
R2	solar pump (P2) with speed control
R3	domestic hot water afterheating pump (P3)
R4	
R5	
RP-R	
RP-M	boiler demand (potential-free), is switched on in parallel to R3
RP-A	

Sensor input	description
S1	temperature collector 1
S2	temperature store base
S3	temperature store top
S6	temperature collector 2
CS10 (optional)	irradiation

channel	description	factory setting	change to	note
COL1	temperature collector 1	-----		
TSTL	temperature store base	-----		
TSTU	temperature store 1 top	-----		
COL2	temperature collector 2	-----		
IRR	irradiation	-----		
n1 %	speed relay 1	-----		
n2 %	speed relay 2	-----		
h P1	operating hours relay 1	-----		
h P2	operating hours relay 2	-----		
h P3	operating hours relay 3	-----		
TIME	time	-----		Adjust the actual clock time.
Arr	arrangement choice	1	19	Arrangement 19: 2 collector-system (east-/west collectors) with 1 store and domestic hot water afterheating
DT O	switch-on temperature difference	6.0 K		Adjust the desired switch-on temperature difference. Note: This value applies to collector 1 and 2
DT F	switch-off temperature difference	4.0 K		Adjust the desired switch-off temperature difference. Note: This value applies to collector 1 and 2
DT S	set temperature difference	10.0 K		Adjust the desired set temperature difference. Note: This value applies to collector 1 and 2
RIS	rise	2 K		If the adjusted temperature difference DTS is reached and if the temperature increases by the difference RIS, the speed will be increased by 10% respectively. Note: This value applies to collector 1 and 2
S MX	maximum store temperature	60 °C		Adjust the desired maximum store temperature
EM1	emergency temperature collector 1	140 °C		Adjust this value to 200°C when the collector emergency shutdown function should not start.
OCX1	option collector cooling collector 1	OFF		
OCN1	option minimum limitation collector 1	OFF		
OCF1	option frost protection collector 1	OFF		
EM2	emergency temperature collector 2	140 °C		Adjust this value to 200°C when the collector emergency shutdown function should not start.
OCX2	option collector cooling collector 2	OFF		
OCN2	option minimum limitation collector 2	OFF		
OCF2	option frost protection collector 2	OFF		
OREC	option recooling	OFF		
OTC	option tube collector	OFF		
NH O	switch-on temperature thermostat 1	40.0 °C		Adjust the desired switch-on temperature for domestic hot water afterheating
NH F	switch-off temperature thermostat 1	45.0 °C		Adjust the desired switch-off temperature for domestic hot water afterheating

channel	description	factory setting	change to	note
t1 O	time frame 1 switch-on temperature	00:00		Up to 3 additional time frames can be selected for the thermostat function (DHW afterheating). The thermostat function (DHW afterheating) will be activated within these time frames only. Example: If the thermostat function (DHW afterheating) should run between 06:00 a.m. and 08:00 a.m.; and 06:00 p.m. and 07:00 p.m., adjust t1 O to 06:00 a.m., t1 F to 08:00 a.m., t2 O to 06:00 p.m. and t2 F to 07:00 p.m.. When all time frames are set to 00:00, the thermostat function (DHW afterheating) is always activated (factory setting).
t1 F	time frame 1 switch-off temperature	00:00		
t2 O	time frame 2 switch-on temperature	00:00		
t2 F	time frame 2 switch-off temperature	00:00		
t3 O	time frame 3 switch-on temperature	00:00		
t3 F	time frame 3 switch-off temperature	00:00		
OHQM	option heat quantity measurement	OFF		
CS 10	solar irradiation sensor	5		
n1MN	minimum speed relay 1	30		
n2MN	minimum speed relay 2	30		
HND1	manual operation relay 1	AUTO		
HND2	manual operation relay 2	AUTO		
HND3	manual operation relay 3	AUTO		
HND4	manual operation relay 4	AUTO		
HND5	manual operation relay 5	AUTO		
HND6	manual operation relay 6	AUTO		
LANG	language	dE		dE = German En = English It = Italian Fr = French
PROG	program number	xx.xx		
VERS	version number	x.xx		

## System Arrangement 20

### System description:

The controller compares the temperatures at the collector sensors S1 and S6 to the store temperature at store sensor S2. If one of the measured temperature differences is higher than the adjusted switch-on temperature differences, the corresponding pump (P1, P2) will be activated and the store

will be loaded. Via another temperature differential function (S3/S4), after-heating of the store can be carried out with a solid fuel boiler (P3).

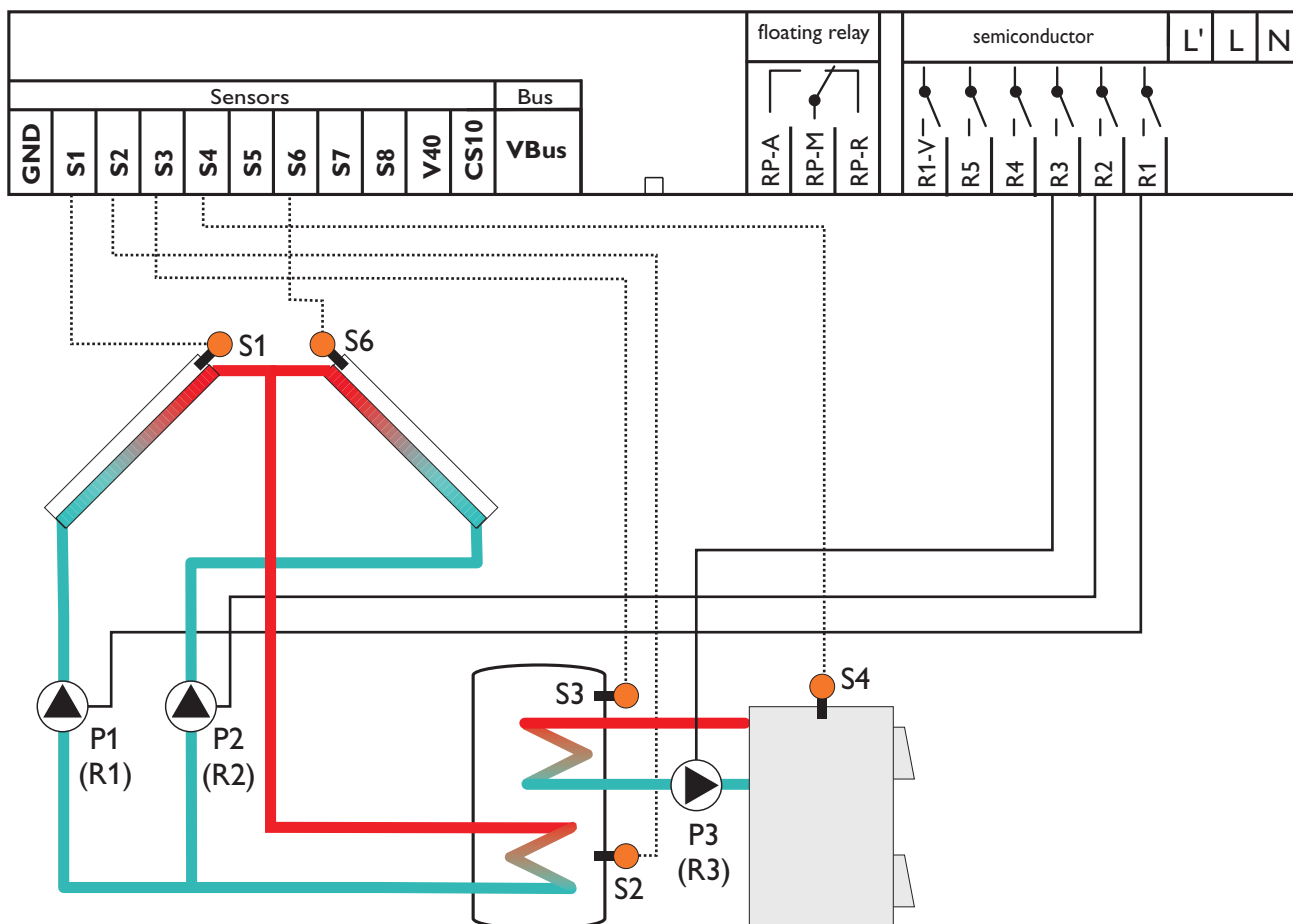

Relay output	Note
R1	solar pump (P1) with speed control
R2	solar pump (P2) with speed control
R3	solid fuel boiler pump (P3) with speed control
R4	
R5	
RP-R	
RP-M	
RP-A	

Sensor input	description
S1	temperature collector 1
S2	temperature store base
S3	temperature store top
S4	temperature solid fuel boiler
S6	temperature collector 2
CS10 (optional)	irradiation

channel	description	factory setting	change to	note
COL1	temperature collector 1	-----		
TSTL	temperature store base	-----		
TSTU	temperature store 1 top	-----		
TSFB	temperature solid fuel boiler	-----		
COL2	temperature collector 2	-----		
IRR	irradiation	-----		
n1 %	speed relay 1	-----		
n2 %	speed relay 2	-----		
n3 %	speed relay 3	-----		
h P1	operating hours relay 1	-----		
h P2	operating hours relay 2	-----		
h P3	operating hours relay 3	-----		
TIME	Time	-----		Adjust the actual clock time.
Arr	arrangement choice	1	20	Arrangement 20: 2 collector-system (east-/west collectors) with 1 store and afterheating with solid fuel boiler
DT O	switch-on temperature difference	6.0 K		Adjust the desired switch-on temperature difference. Note: This value applies to collector 1 and 2
DT F	switch-off temperature difference	4.0 K		Adjust the desired switch-off temperature difference. Note: This value applies to collector 1 and 2
DT S	set temperature difference	10.0 K		Adjust the desired set temperature difference Note: This value applies to collector 1 and 2
RIS	rise	2 K		If the adjusted temperature difference DTS is reached and if the temperature increases by the difference RIS, the speed will be increased by 10% respectively. Note: This value applies to collector 1 and 2
S MX	maximum store temperature	60 °C		Adjust the desired maximum store temperature
EM1	emergency temperature collector 1	140 °C		Adjust this value to 200°C when the collector emergency shutdown function should not start.
OCX1	option collector cooling collector 1	OFF		
OCN1	option minimum limitation collector 1	OFF		
OCF1	option frost protection collector 1	OFF		
EM2	emergency temperature collector 2	140 °C		Adjust this value to 200°C when the collector emergency shutdown function should not start.
OCX2	option collector cooling collector 2	OFF		
OCN2	option minimum limitation collector 2	OFF		
OCF2	option frost protection collector 2	OFF		
OREC	option recooling	OFF		
OTC	option tube collector	OFF		
DT3O	switch-on temperature difference 3	6.0 K		Adjust the desired switch-on temperature for store charging pump - solid fuel boiler

channel	description	factory setting	change to	note
DT3F	switch-off temperature difference 3	4.0 K		Adjust the desired switch-off temperature difference for store charging pump - solid fuel boiler
DT3S	set temperature DT3	10.0 K		Adjust the desired set temperature difference for store charging pump - solid fuel boiler
RIS3	rise DT3	2 K		If the adjusted temperature difference DT3S is reached and if the temperature increases by the difference RIS3, speed relay 3 will be increased by 10% respectively.
MX3O	switch-on threshold for maximum temperature	60,0 °C		Adjust the desired maximum store temperature for switching off the solid fuel burner pump (P3) Note: When the maximum store temperature (MX3O) at sensor S3 is reached, pump P3 is switched off. When the store temperature falls below MX3F at S3, the pump is switched-on again.
MX3F	switch-off threshold for maximum temperature	58.0 °C		
MN3O	switch-on threshold for minimum temperature	60,0 °C		Adjust the desired minimum temperature for releasing pump P3 Note: Pump 3 is switched on when the solid fuel boiler (S4) reaches 65 °C (MN3F) and when there is a temperature difference (DT3O) to store sensor S3. It is switched off when the temperature of the solid fuel boiler falls to 60 °C (MN3O), the temperature difference falls below the switch-off temperature difference (DT3F) or when the store maximum temperature (MX3O) at sensor S3 is reached.
MN3F	switch-off threshold for minimum temperature	65.0 °C		
OHQM	option heat quantity measurement	OFF		
CS 10	solar irradiation sensor	5		
n1MN	minimum speed relay 1	30		
n2MN	minimum speed relay 2	30		
n3MN	minimum speed relay 3	30		
HND1	manual operation relay 1	AUTO		
HND2	manual operation relay 2	AUTO		
HND3	manual operation relay 3	AUTO		
HND4	manual operation relay 4	AUTO		
HND5	manual operation relay 5	AUTO		
HND6	manual operation relay 6	AUTO		
LANG	language	dE		dE = German En = English It = Italian Fr = French
PROG	program number	xx.xx		
VERS	version number	x.xx		

## System Arrangement 21

### System description:

The controller compares the temperatures at collector sensors S1 and S6 to the store temperature at store sensor S2. If one of the measured temperature differences is higher than the adjusted switch-on temperature differences, the corresponding pump (P1, P2) will be activated and the store

will be loaded.

With another temperature differential function (S3 heat source / S5 heat sink) heating circuit return preheating is possible via V1.

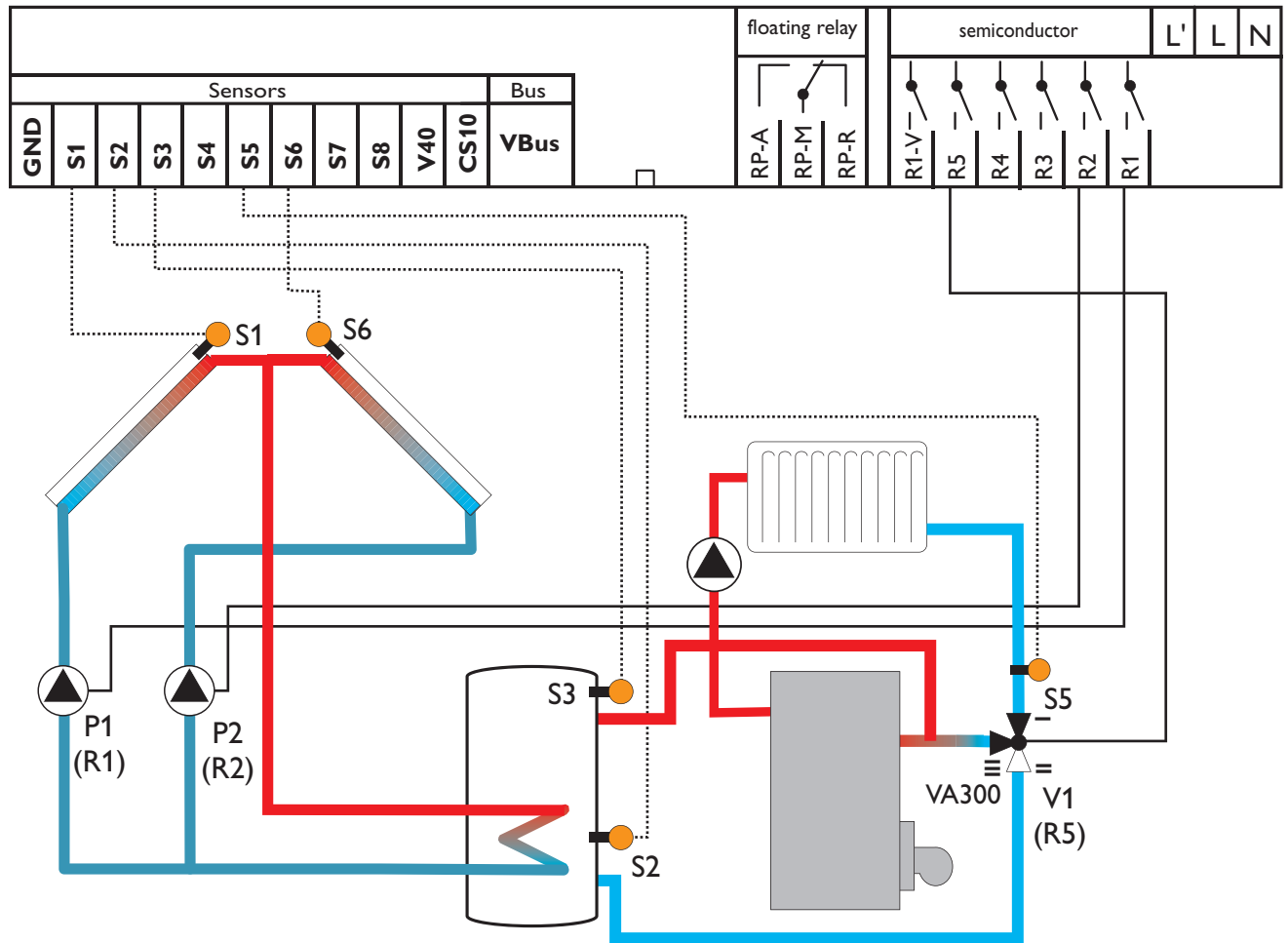

Note: 3-port valve V1 normally open - boiler

Relay output	Note
R1	solar pump (P1) with speed control
R2	solar pump (P2) with speed control
R3	
R4	
R5	3-port valve (V2) heating circuit return preheating
RP-R	
RP-M	
RP-A	

Sensor input	description
S1	temperature collector 1
S2	temperature store base
S3	temperature store top
S5	temperature heating circuit
S6	temperature collector 2
CS10 (optional)	irradiation

channel	description	factory setting	change to	note
COL1	temperature collector 1	-----		
TSTL	temperature store base	-----		
TSTU	temperature store 1 top	-----		
TREC	temperature heating circuit	-----		
COL2	temperature collector 2	-----		
IRR	irradiation	-----		
n1 %	speed relay 1	-----		
n2 %	speed relay 2	-----		
h P1	operating hours relay 1	-----		
h P2	operating hours relay 2	-----		
TIME	time	-----		Adjust the actual clock time.
Arr	arrangement choice	1	21	Arrangement 21: 2 collector-system (east-/west collectors) with 1 store and heating circuit return preheating
DT O	switch-on temperature difference	6.0 K		Adjust the desired switch-on temperature difference. Note: This value applies to collector 1 and 2
DT F	switch-off temperature difference	4.0 K		Adjust the desired switch-off temperature difference. Note: This value applies to collector 1 and 2
DT S	set temperature difference	10.0 K		Adjust the desired set temperature difference Note: This value applies to collector 1 and 2
RIS	rise	2 K		If the adjusted temperature difference DTS is reached and if the temperature increases by the difference RIS, the speed will be increased by 10% respectively. Note: This value applies to collector 1 and 2
S MX	maximum store temperature	60 °C		Adjust the desired maximum store temperature
EM1	emergency temperature collector 1	140 °C		Adjust this value to 200°C when the collector emergency shutdown function should not start.
OCX1	option collector cooling collector 1	OFF		
OCN1	option minimum limitation collector 1	OFF		
OCF1	option frost protection collector 1	OFF		
EM2	emergency temperature collector 2	140 °C		Adjust this value to 200°C when the collector emergency shutdown function should not start.
OCX2	option collector cooling collector 2	OFF		
OCN2	option minimum limitation collector 2	OFF		
OCF2	option frost protection collector 2	OFF		
OREC	option recooling	OFF		
OTC	option tube collector	OFF		
DT3O	switch-on temperature difference 3	6.0 K		Adjust the desired switch-on temperature difference for heating circuit return preheating



channel	description	factory setting	change to	note
<b>DT3F</b>	switch-off temperature difference 3	<b>4.0 K</b>		<b>Adjust the desired switch-off temperature difference for heating circuit return preheating (heating circuit backup)</b>
<b>OHQM</b>	option heat quantity measurement	<b>OFF</b>		
<b>CS 10</b>	solar irradiation sensor	<b>5</b>		
<b>n1MN</b>	minimum speed relay 1	<b>30</b>		
<b>n2MN</b>	minimum speed relay 2	<b>30</b>		
<b>HND1</b>	manual operation relay 1	<b>AUTO</b>		
<b>HND2</b>	manual operation relay 2	<b>AUTO</b>		
<b>HND3</b>	manual operation relay 3	<b>AUTO</b>		
<b>HND4</b>	manual operation relay 4	<b>AUTO</b>		
<b>HND5</b>	manual operation relay 5	<b>AUTO</b>		
<b>HND6</b>	manual operation relay 6	<b>AUTO</b>		
<b>LANG</b>	language	<b>dE</b>		<b>dE = German En = English It = Italian Fr = French</b>
<b>PROG</b>	program number	<b>xx.xx</b>		
<b>VERS</b>	version number	<b>x.xx</b>		

## System Arrangement 22

### System description:

The controller compares the temperatures at the collector sensors S1 and S6 to the store temperature at store sensor S2. If one of the measured temperature differences is higher than the adjusted switch-on temperature differences, the corresponding pump (P1, P2) will be activated and the store will be loaded.

With another temperature differential function (S3 heat source / S5 heat sink) heating circuit return preheating is possible via V1. With a thermostat function (S3) domestic hot water afterheating (P3) can be carried out.

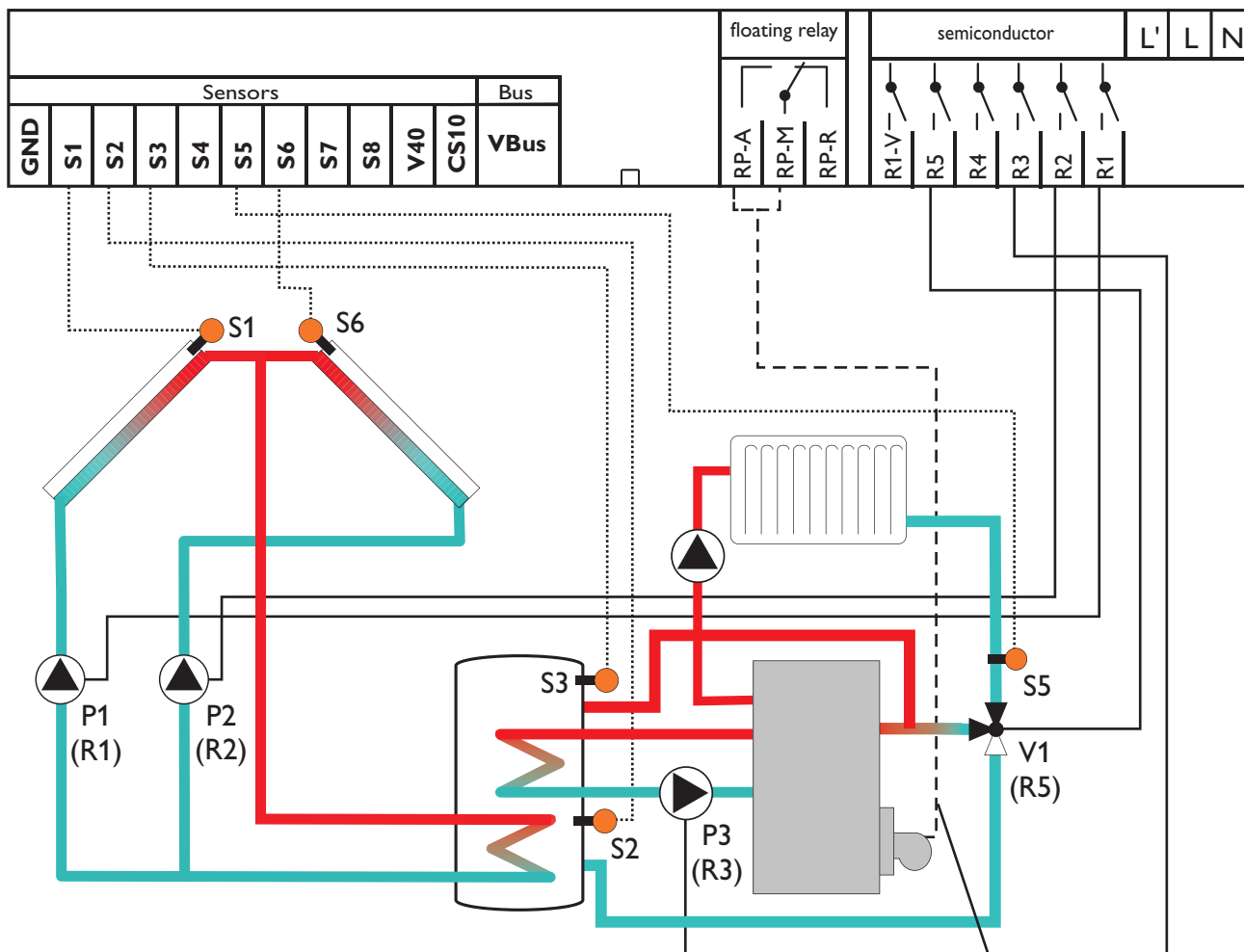

Note:  
Relay RP is energised in parallel to R3 in order to enable a boiler demand (potential-free relay)

Relay output	Note
R1	solar pump (P1) with speed control
R2	solar pump (P2) with speed control
R3	charging pump domestic hot water afterheating (P3)
R4	
R5	3-port valve (V2) heating circuit return preheating
RP-R	
RP-M	boiler demand (potential-free), is switched on in parallel to R3
RP-A	

Sensor input	description
S1	temperature collector 1
S2	temperature store base
S3	temperature store top
S5	temperature heating circuit
S6	temperature collector 2
CS10 (optional)	irradiation

channel	description	factory setting	change to	note
COL1	temperature collector 1	-----		
TSTL	temperature store base	-----		
TSTU	temperature store 1 top	-----		
TREC	temperature heating circuit	-----		
COL2	temperature collector 2	-----		
IRR	irradiation	-----		
n1 %	speed relay 1	-----		
n2 %	speed relay 2	-----		
h P1	operating hours relay 1	-----		
h P2	operating hours relay 2	-----		
h P3	operating hours relay 3	-----		
TIME	time	-----		Adjust the actual clock time.
Arr	arrangement choice	1	22	Arrangement 22: 2-collector-system (east-/west collectors) with 1 store, heating circuit return pre-heating and domestic hot water afterheating
DT O	switch-on temperature difference	6.0 K		Adjust the desired switch-on temperature difference. Note: This value applies to collector 1 and 2
DT F	switch-off temperature difference	4.0 K		Adjust the desired switch-off temperature difference. Note: This value applies to collector 1 and 2
DT S	set temperature difference	10.0 K		Adjust the desired set temperature difference. Note: This value applies to collector 1 and 2
RIS	rise	2 K		If the adjusted temperature difference DTS is reached and if the temperature increases by the difference RIS, the speed will be increased by 10% respectively. Note: This value applies to collector 1 and 2
S MX	maximum store temperature	60 °C		Adjust the desired maximum store temperature
EM1	emergency temperature collector 1	140 °C		Adjust this value to 200°C when the collector emergency shutdown function should not start.
OCX1	option collector cooling collector 1	OFF		
OCN1	option minimum limitation collector 1	OFF		
OCF1	option frost protection collector 1	OFF		
EM2	emergency temperature collector 2	140 °C		Adjust this value to 200°C when the collector emergency shutdown function should not start.
OCX2	option collector cooling collector 2	OFF		
OCN2	option minimum limitation collector 2	OFF		
OCF2	option frost protection collector 2	OFF		
OREC	option recooling	OFF		
OTC	option tube collector	OFF		

channel	description	factory setting	change to	note
DT3O	switch-on temperature difference 3	6.0 K		Adjust the desired switch-on temperature difference for heating circuit return preheating (heating circuit backup)
DT3F	switch-off temperature difference 3	4.0 K		Adjust the desired switch-off temperature difference for for heating circuit return preheating (heating circuit backup)
NH O	switch-on temperature thermostat 1	40.0 °C		Adjust the desired switch-on temperature difference for domestic hot water afterheating
NH F	switch-off temperature thermostat 1	45.0 °C		Adjust the desired switch-off temperature difference for domestic hot water afterheating
t1 O	time frame 1 switch-on temperature	00:00		Up to 3 additional time frames can be selected for the thermostat function (DHW afterheating). The thermostat function (DHW afterheating) will be activated within these time frames only. Example: If the thermostat function should run from 06:00 a.m. and 08:00 a.m.; and 06:00 p.m. and 07:00 p.m. only, adjust t1O to 06:00 a.m., t1F to 08:00 a.m., t2O to 06:00 p.m. and t2F to 07:00 p.m.. When all time frames are set to 00:00, the thermostat function (DHW afterheating) is always activated (factory setting).
t1 F	time frame 1 switch-off temperature	00:00		
t2 O	time frame 2 switch-on temperature	00:00		
t2 F	time frame 2 switch-off temperature	00:00		
t3 O	time frame 3 switch-on temperature	00:00		
t3 F	time frame 3 switch-off temperature	00:00		
OHQM	option heat quantity measurement	OFF		
CS 10	solar irradiation sensor	5		
n1MN	minimum speed relay 1	30		
n2MN	minimum speed relay 2	30		
HND1	manual operation relay 1	AUTO		
HND2	manual operation relay 2	AUTO		
HND3	manual operation relay 3	AUTO		
HND4	manual operation relay 4	AUTO		
HND5	manual operation relay 5	AUTO		
HND6	manual operation relay 6	AUTO		
LANG	language	dE		dE = German En = English It = Italian Fr = French
PROG	program number	xx.xx		
VERS	version number	x.xx		

## System Arrangement 23

### System description:

The controller compares the temperatures at the collector sensors S1 and S6 to the store temperatures at the store sensors S2 and S3. If one of the measured temperature differences is higher than the adjusted switch-on differences, the corresponding pump (P1, P2) is switched on and the

corresponding store zone is loaded up to the maximum temperature at most via valve (V1). The priority logic causes priority loading of the upper zone of the store.

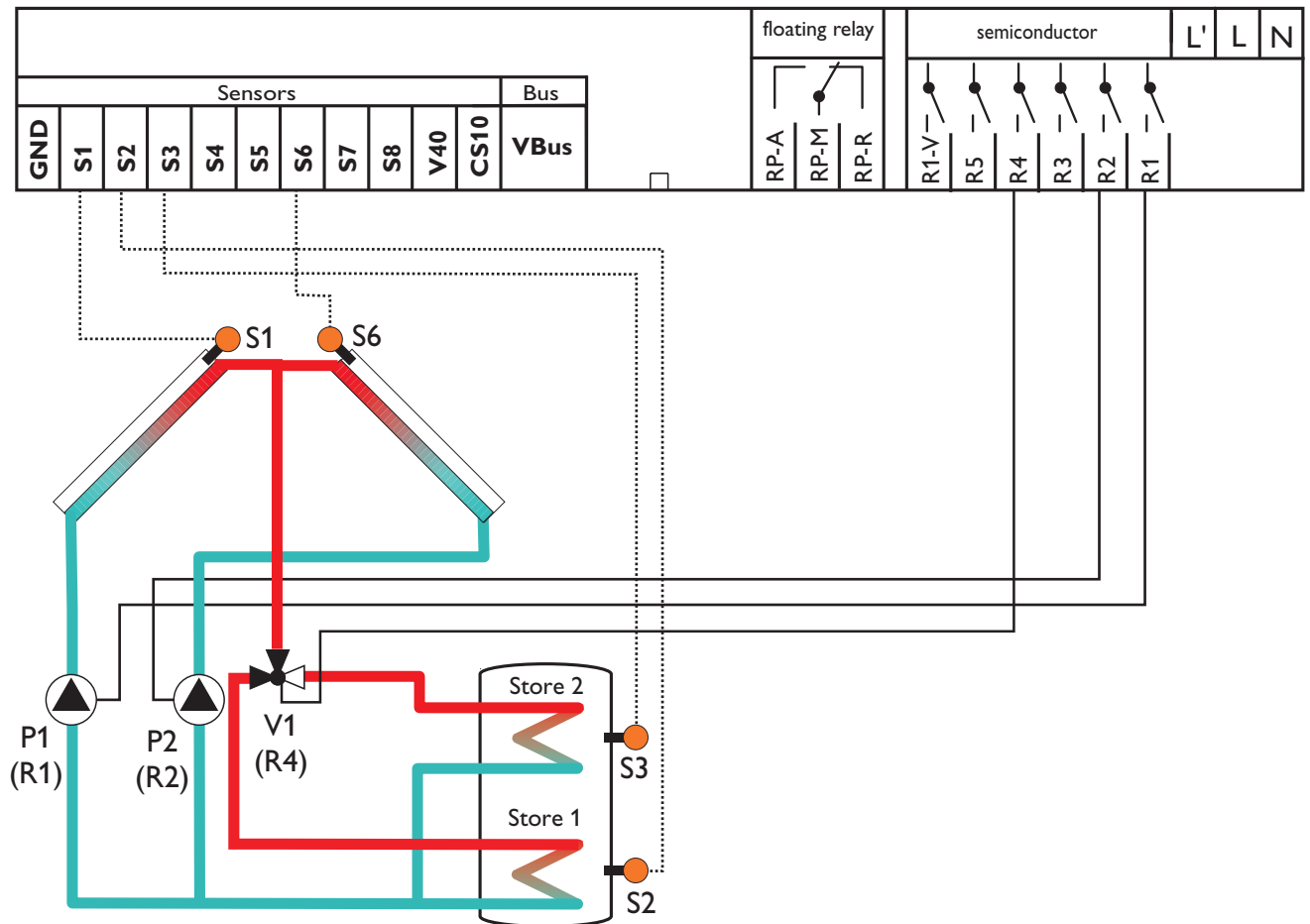

Note: 3-port valve V1 normally open - store base

Relay output	Note
R1	solar pump (P1) with speed control
R2	solar pump (P2) with speed control
R3	
R4	3-port valve (V1) store top/base
R5	
RP-R	
RP-M	
RP-A	

Sensor input	description
S1	temperature collector 1
S2	temperature store base
S3	temperature store top
S6	temperature collector 2
CS10 (optional)	irradiation

channel	description	factory setting	change to	note
COL1	temperature collector 1	-----		
TSTL	temperature store base	-----		
TSTU	temperature store 1 top	-----		
COL2	temperature collector 2	-----		
IRR	irradiation	-----		
n1 %	speed relay 1	-----		
n2 %	speed relay 2	-----		
h P1	operating hours relay 1	-----		
h P2	operating hours relay 2	-----		
TIME	time	-----		Adjust the actual clock time.
Arr	arrangement choice	1	23	Arrangement 23: 2-collector-system (east-/west collectors) with multi-layer store system
DT1O	switch-on temperature difference 1	6.0 K		Adjust the desired switch-on temperature difference for store 1. Note: This value applies to collector 1 and 2
DT1F	switch-off temperature difference 1	4.0 K		Adjust the desired switch-off temperature difference for store 1. Note: This value applies to collector 1 and 2
DT1S	set temperature difference 1	10.0 K		Adjust the desired set temperature difference for store 1. Note: This value applies to collector 1 and 2
RIS1	rise 1	2 K		If the adjusted temperature difference DT1S is reached and if the temperature increases by the difference RIS1, the speed will be increased by 10% respectively. Note: This value applies to collector 1 and 2
S1MX	maximum temperature store 1	60 °C		Adjust the desired maximum store temperature for store 1.
DT2O	switch-on temperature difference 2	6.0 K		Adjust the desired switch-on temperature difference for store 2. Note: This value applies to collector 1 and 2
DT2F	switch-off temperature difference 2	4.0 K		Adjust the desired switch-off temperature difference for store 2. Note: This value applies to collector 1 and 2
DT2S	set temperature difference 2	10.0 K		Adjust the desired set temperature difference for store 2. Note: This value applies to collector 1 and 2
RIS2	rise 2	2 K		If the adjusted temperature difference DT2S is reached and if the temperature increases by the difference RIS2, the speed will be increased by 10% respectively. Note: This value applies to collector 1 and 2
S2MX	maximum temperature store 2	60 °C		Adjust the desired maximum store temperature for store 2.
EM1	emergency temperature collector 1	140 °C		Adjust this value to 200°C when the collector emergency shutdown function should not start.
OCX1	option collector cooling collector 1	OFF		
OCN1	option minimum limitation collector 1	OFF		

channel	description	factory setting	change to	note
OCF1	option frost protection collector 1	OFF		
EM2	emergency temperature collector 2	140 °C		Adjust this value to 200°C when the collector emergency shutdown function should not start.
OCX2	option collector cooling collector 2	OFF		
OCN2	option minimum limitation collector 2	OFF		
OCF2	option frost protection collector 2	OFF		
PRIO	priority	2		priority store top
tST	break time	2 Min.		The loading break time for the priority logic function can be changed (see appendix priority logic)
tRUN	runtime	15 Min.		The oscillating loading time for the priority logic function can be changed (see appendix priority logic)
OREC	option recooling	OFF		
OTC	option tube collector	OFF		
OHQM	option heat quantity measurement	OFF		
CS 10	solar irradiation sensor	5		
n1MN	minimum speed relay 1	30		
n2MN	minimum speed relay 2	30		
HND1	manual operation relay 1	AUTO		
HND2	manual operation relay 2	AUTO		
HND3	manual operation relay 3	AUTO		
HND4	manual operation relay 4	AUTO		
HND5	manual operation relay 5	AUTO		
HND6	manual operation relay 6	AUTO		
LANG	language	dE		dE = German En = English It = Italian Fr = French
PROG	program number	xx.xx		
VERS	version number	x.xx		

Information on priority logic can be found on page 115.

## System Arrangement 24

### System description:

The controller compares the temperatures at the collector sensors S1 and S6 to the store temperatures at the store sensors S2 and S3. If one of the measured temperature differences is higher than the adjusted switch-on differences, the corresponding pump (P1, P2) is switched on and the corresponding store zone is loaded up to the maximum temperature at most via the valve (V1). The priority logic

causes priority loading of the upper zone of the store. Heat transfer control to an existant store (P3) can be carried out via another temperature differential function (S3 heat source/S4 heat sink).

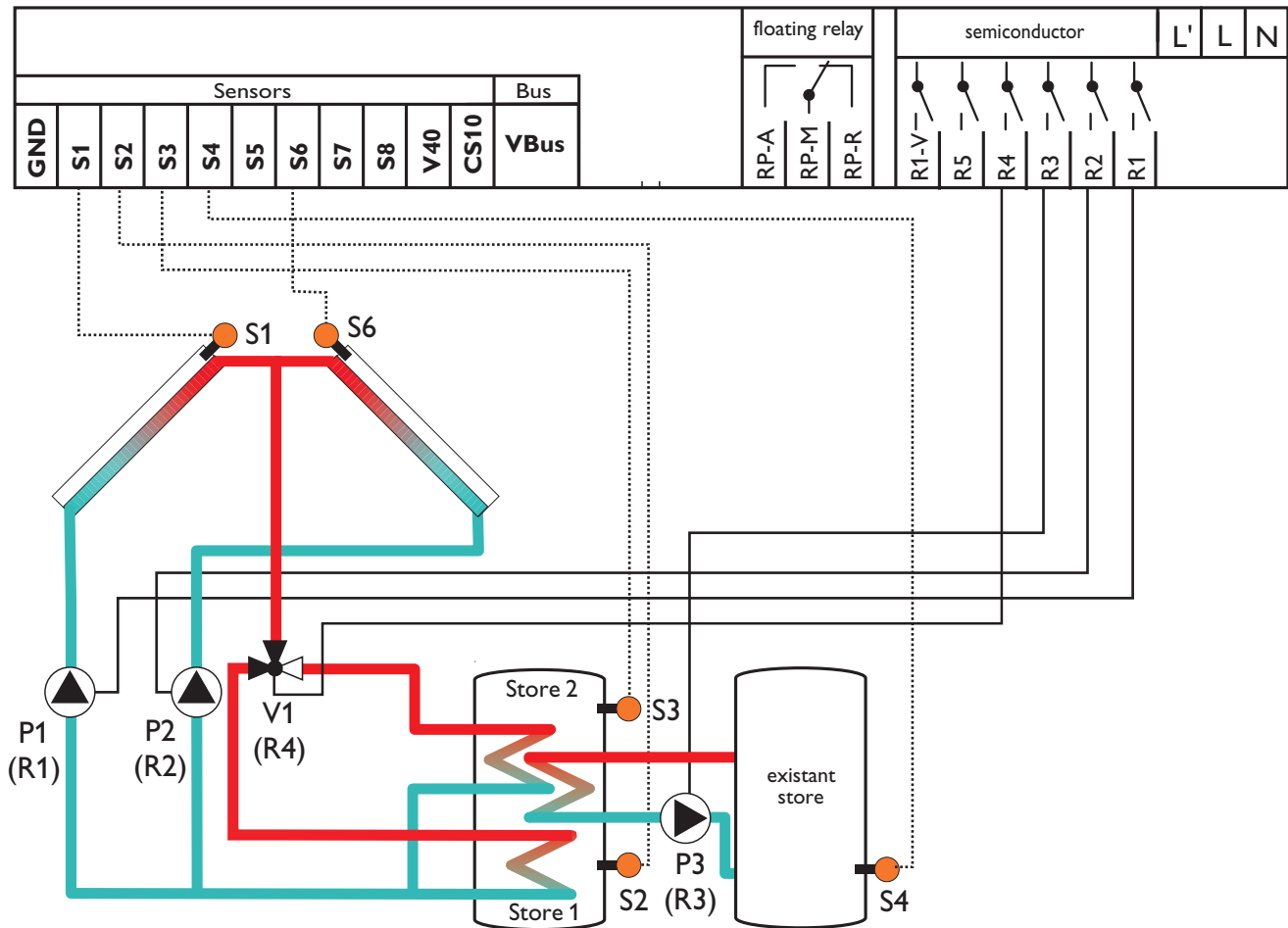

Note: 3-port valve V1 normally open - store base

Relay output	Note
R1	solar pump (P1) with speed control
R2	solar pump (P2) with speed control
R3	pump heat exchange (P3)
R4	3-port valve (V1) store top/base
R5	
RP-R	
RP-M	
RP-A	

Sensor input	description
S1	temperature collector 1
S2	temperature store 1 base
S3	temperature store 1 top
S4	temperature store 2 base
S6	temperature collector 2
CS10 (optional)	irradiation



channel	description	factory setting	change to	note
COL1	temperature collector 1	-----		
TST1	temperature store 1 base	-----		
TSTU	temperature store 1 top	-----		
TST2	temperature store 2 base	-----		
COL2	temperature collector 2	-----		
IRR	irradiation	-----		
n1 %	speed relay 1	-----		
n2 %	speed relay 2	-----		
n3 %	speed relay 3	-----		
h P1	operating hours relay 1	-----		
h P2	operating hours relay 2	-----		
h P3	operating hours relay 3	-----		
TIME	Time	-----		Adjust the actual clock time.
Arr	arrangement choice	1	24	Arrangement 24: 2-collector-system (east-/west collectors) with multi-layer store and heat exchange control to another store
DT1O	switch-on temperature difference 1	6.0 K		Adjust the desired switch-on temperature difference for store 1. Note: This value applies to collector 1 and 2
DT1F	switch-off temperature difference 1	4.0 K		Adjust the desired maximum store temperature for store 1. Note: This value applies to collector 1 and 2
DT1S	set temperature difference 1	10.0 K		Adjust the desired set temperature difference for store 1. Note: This value applies to collector 1 and 2
RIS1	rise 1	2 K		If the adjusted temperature difference DT1S is reached and if the temperature increases by the difference RIS1, the speed will be increased by 10% respectively. Note: This value applies to collector 1 and 2
S1MX	maximum temperature store 1	60 °C		Adjust the desired maximum store temperature for store 1.
DT2O	switch-on temperature difference 2	6.0 K		Adjust the desired switch-on temperature difference for store 2. Note: This value applies to collector 1 and 2
DT2F	switch-off temperature difference 2	4.0 K		Adjust the desired switch-off temperature difference for store 2. Note: This value applies to collector 1 and 2
DT2S	set temperature difference 2	10.0 K		Adjust the desired set temperature difference store 2 Note: This value applies to collector 1 and 2
RIS2	rise 2	2 K		If the adjusted temperature difference DT2S is reached and if the temperature increases by the difference RIS2, the speed will be increased by 10% respectively. Note: This value applies to collector 1 and 2
S2MX	maximum temperature store 2	60 °C		Adjust the desired maximum store temperature for store 2.

channel	description	factory setting	change to	note
EM1	emergency temperature collector 1	140 °C		Adjust this value to 200°C when the collector emergency shutdown function should not start.
OCX1	option collector cooling collector 1	OFF		
OCN1	option minimum limitation collector 1	OFF		
OCF1	option frost protection collector 1	OFF		
EM2	emergency temperature collector 2	140 °C		Adjust this value to 200°C when the collector emergency shutdown function should not start.
OCX2	option collector cooling collector 2	OFF		
OCN2	option minimum limitation collector 2	OFF		
OCF2	option frost protection collector 2	OFF		
PRIO	priority	2		priority store top
tST	break time	2 Min.		The loading break time for the priority logic function can be changed (see appendix priority logic)
tRUN	runtime	15 Min.		The oscillating loading time for the priority logic function can be changed (see appendix priority logic)
OREC	option recooling	OFF		
OTC	option tube collector	OFF		
DT3O	switch-on temperature difference 3	6.0 K		Adjust the desired switch-on temperature difference for heat exchange control
DT3F	switch-off temperature difference 3	4.0 K		Adjust the desired switch-off temperature difference for heat exchange control
DT3S	set temperature DT3	10.0 K		Adjust the desired set temperature difference for heat exchange control
RIS3	rise DT3	2 K		If the adjusted temperature difference DT3S is reached and if the temperature increases by the difference RIS3, speed relay 3 (P3) will be increased by 10% respectively.
MX3O	switch-on threshold for maximum temp.	60,0 °C		Adjustment the desired maximum store temperature for the existing store (pump P3) Note: If the maximum store temperature (MX3O) at sensor S4 is reached, pump P3 is switched off. If the store temperature falls below MX3F at S4, the pump is switched-on again.
MX3F	switch-off threshold for maximum temperature	58.0 °C		
MN3O	switch-on threshold for minimum temperature	5,0		A minimum temperature for releasing pump P3 can be adjusted. Note: If pump P3 should switch on e.g. at a temperature of 60 °C in the solar store (measured at S3), adjust the following values: MN3O = 55 °C MN3F = 60 °C. The pump will then be switched on again, if 60 °C is reached. It will be blocked if the temperature falls below 55 °C.
MN3F	switch-off threshold for minimum temperature	10.0 °C		

channel	description	factory setting	change to	note
<b>OHQM</b>	option heat quantity measurement	<b>OFF</b>		
<b>CS 10</b>	solar irradiation sensor	<b>5</b>		
<b>n1MN</b>	minimum speed relay 1	<b>30</b>		
<b>n2MN</b>	minimum speed relay 2	<b>30</b>		
<b>n3MN</b>	minimum speed relay 3	<b>30</b>		
<b>HND1</b>	manual operation relay 1	<b>AUTO</b>		
<b>HND2</b>	manual operation relay 2	<b>AUTO</b>		
<b>HND3</b>	manual operation relay 3	<b>AUTO</b>		
<b>HND4</b>	manual operation relay 4	<b>AUTO</b>		
<b>HND5</b>	manual operation relay 5	<b>AUTO</b>		
<b>HND6</b>	manual operation relay 6	<b>AUTO</b>		
<b>LANG</b>	language	<b>dE</b>		<b>dE = German En = English It = Italian Fr = French</b>
<b>PROG</b>	program number	<b>xx.xx</b>		
<b>VERS</b>	version number	<b>x.xx</b>		

Information on priority logic can be found on page 115.

## System Arrangement 25

### System description:

The controller compares the temperatures at the collector sensors S1 and S6 to the store temperatures at the store sensors S2 and S3. If one of the measured temperature differences is higher than the adjusted switch-on differences, the corresponding pump (P1, P2) is switched on and the corresponding store zone is loaded up to the maximum

temperature at most via the valve (V1). The priority logic causes priority loading of the upper zone of the store. Domestic hot water afterheating (P3) is possible via a thermostat function (S3).

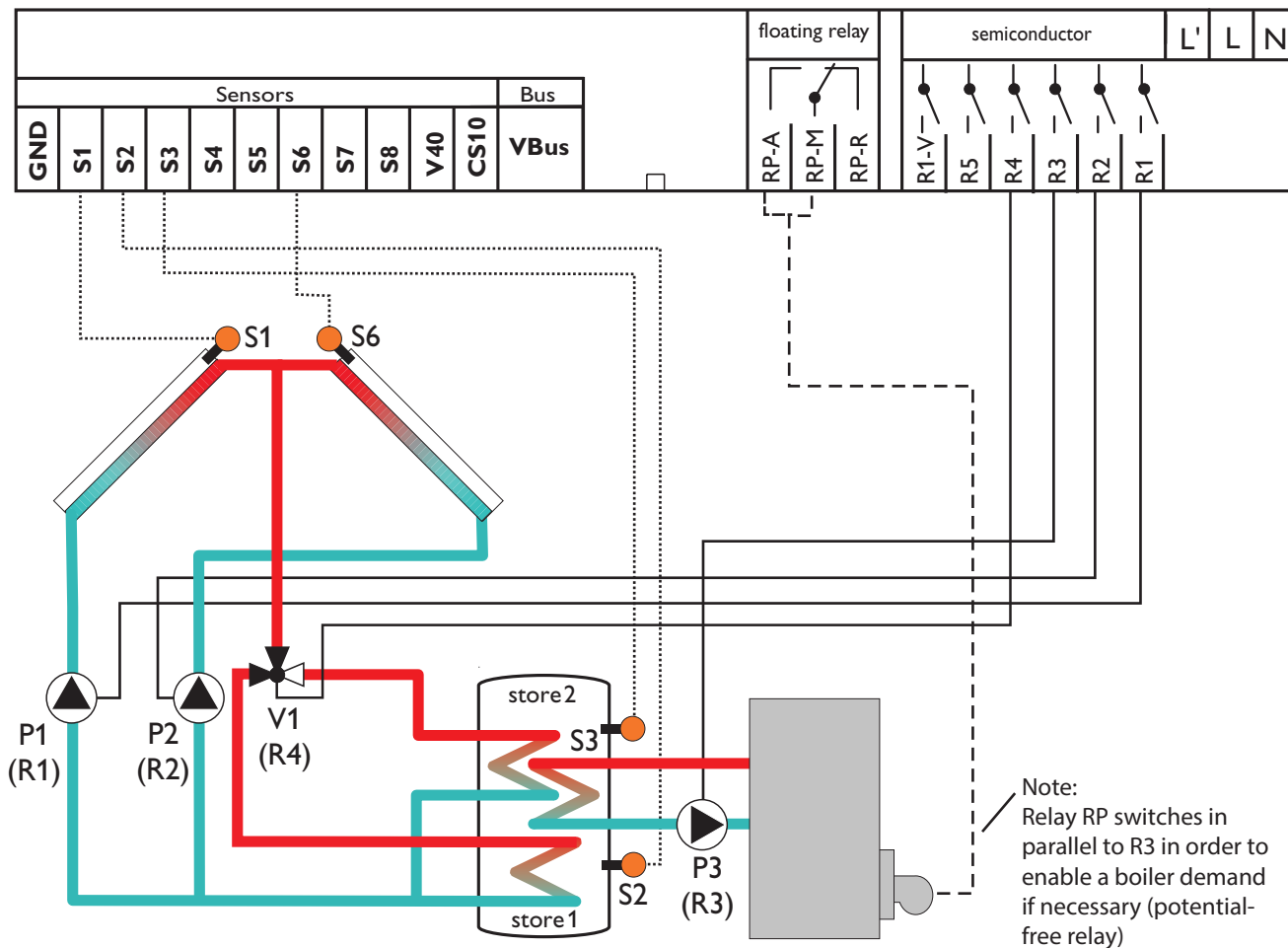

Note: 3-port valve V1 normally open - store base

Relay output	Note
R1	solar pump (P1) with speed control
R2	solar pump (P2) with speed control
R3	domestic hot water afterheating (P3)
R4	3-port valve (V1) store top/base
R5	
RP-R	
RP-M	boiler demand (potential-free), is switched on in parallel to R3
RP-A	

Sensor input	description
S1	temperature collector 1
S2	temperature store base
S3	temperature store top
S6	temperature collector 2
CS10 (optional)	irradiation

channel	description	factory setting	change to	note
COL1	temperature collector 1	-----		
TSTL	temperature store base	-----		
TSTU	temperature store top	-----		
COL2	temperature collector 2	-----		
IRR	irradiation	-----		
n1 %	speed relay 1	-----		
n2 %	speed relay 2	-----		
h P1	operating hours relay 1	-----		
h P2	operating hours relay 2	-----		
h P3	operating hours relay 3	-----		
TIME	time	-----		Adjust the actual clock time.
Arr	arrangement choice	1	25	Arrangement 25: 2 collector-system (east-/west collectors) multi-layer store system with domestic hot water afterheating
DT1O	switch-on temperature difference 1	6.0 K		Adjust the desired switch-on temperature difference for store 1. Note: This value applies to collector 1 and 2
DT1F	switch-off temperature difference 1	4.0 K		Adjust the desired switch-off temperature difference for store 1. Note: This value applies to collector 1 and 2
DT1S	set temperature difference 1	10.0 K		Adjust the desired set temperature difference for store 1. Note: This value applies to collector 1 and 2
RIS1	rise 1	2 K		If the adjusted temperature difference DT1S is reached and if the temperature increases by the difference RIS1, the speed will be increased by 10% respectively. Note: This values applies to collector 1 and 2
S1MX	maximum temperature store 1	60		Adjust the desired maximum store temperature for store 1.
DT2O	switch-on temperature difference 2	6.0 K		Adjust the desired switch-on temperature difference for store 2. Note: This value applies to collector 1 and 2
DT2F	switch-off temperature difference 2	4.0 K		Adjust the desired switch-off temperature difference for store 2. Note: This value applies to collector 1 and 2
DT2S	set temperature difference 2	10.0 K		Adjust the desired set temperature difference for store 2. Note: This value applies to collector 1 and 2
RIS2	rise 2	2 K		If the adjusted temperature difference DT2S is reached and if the temperature increases by the difference RIS2, the speed will be increased by 10% respectively. Note: This value applies to collector 1 and 2
S2MX	maximum temperature store 2	60 °C		Adjust the desired maximum store temperature for store 2.
EM1	emergency temperature collector 1	140 °C		Adjust this value to 200°C when the collector emergency shutdown function should not start.
OCX1	option collector cooling collector 1	OFF		
OCN1	option minimum limitation collector 1	OFF		
OCF1	option frost protection collector 1	OFF		

channel	description	factory setting	change to	note
EM2	emergency temperature collector 2	140 °C		Adjust this value to 200°C when the collector emergency shutdown function should not start.
OCX2	option collector cooling collector 2	OFF		
OCN2	option minimum limitation collector 2	OFF		
OCF2	option frost protection collector 2	OFF		
PRIO	priority	2		priority store top
tST	break time	2 Min.		The loading break time for the priority logic function can be changed (see appendix priority logic)
tRUN	runtime	15 Min.		The oscillating loading time for the priority logic function can be changed (see appendix priority logic)
OREC	option recooling	OFF		
OTC	option tube collector	OFF		
NH O	switch-on temperature thermostat 1	40.0 °C		Adjust the desired switch-on temperature difference for domestic hot water afterheating
NH F	switch-off temperature thermostat 1	45.0 °C		Adjust the desired switch-off temperature difference for domestic hot water afterheating
t1 O	time frame 1 switch-on temperature	00:00		Up to 3 additional time frames can be selected for the thermostat function (DHW afterheating). The thermostat function (DHW afterheating) will be activated within these time frames only. Example: If the thermostat function (DHW afterheating) should run from 06:00 a.m. and 08:00 a.m.; and 06:00 p.m. and 07:00 p.m. only, adjust t1O to 06:00 a.m., t1F to 08:00 a.m., t2O to 06:00 p.m. and t2F to 07:00 p.m.. When all time frames are set to 00:00, the thermostat function (DHW afterheating) is always activated (factory setting).
t1 F	time frame 1 switch-off temperature	00:00		
t2 O	time frame 2 switch-on temperature	00:00		
t2 F	time frame 2 switch-off temperature	00:00		
t3 O	time frame 3 switch-on temperature	00:00		
t3 F	time frame 3 switch-off temperature	00:00		
OHQM	option heat quantity measurement	OFF		
CS 10	solar irradiation sensor	5		
n1MN	minimum speed relay 1	30		
n2MN	minimum speed relay 2	30		
HND1	manual operation relay 1	AUTO		
HND2	manual operation relay 2	AUTO		
HND3	manual operation relay 3	AUTO		
HND4	manual operation relay 4	AUTO		
HND5	manual operation relay 5	AUTO		
HND6	manual operation relay 6	AUTO		
LANG	language	dE		dE = German En = English It = Italian Fr = French
PROG	program number	xx.xx		
VERS	version number	x.xx		

Information on priority logic can be found on page 115.

## System Arrangement 26

### System description:

The controller compares the temperatures at the collector sensors S1 and S6 to the store temperatures at the store sensors S2 and S3. If one of the measured temperature differences is higher than the adjusted switch-on differences, the corresponding pump (P1, P2) is switched on and the corresponding store zone is loaded up to the maximum temperature at most via the valve (V1). The priority logic

causes priority loading of the upper zone of the store. With another temperature differential function (S4/S43), afterheating of the store can be carried out with a solid fuel boiler (P3).

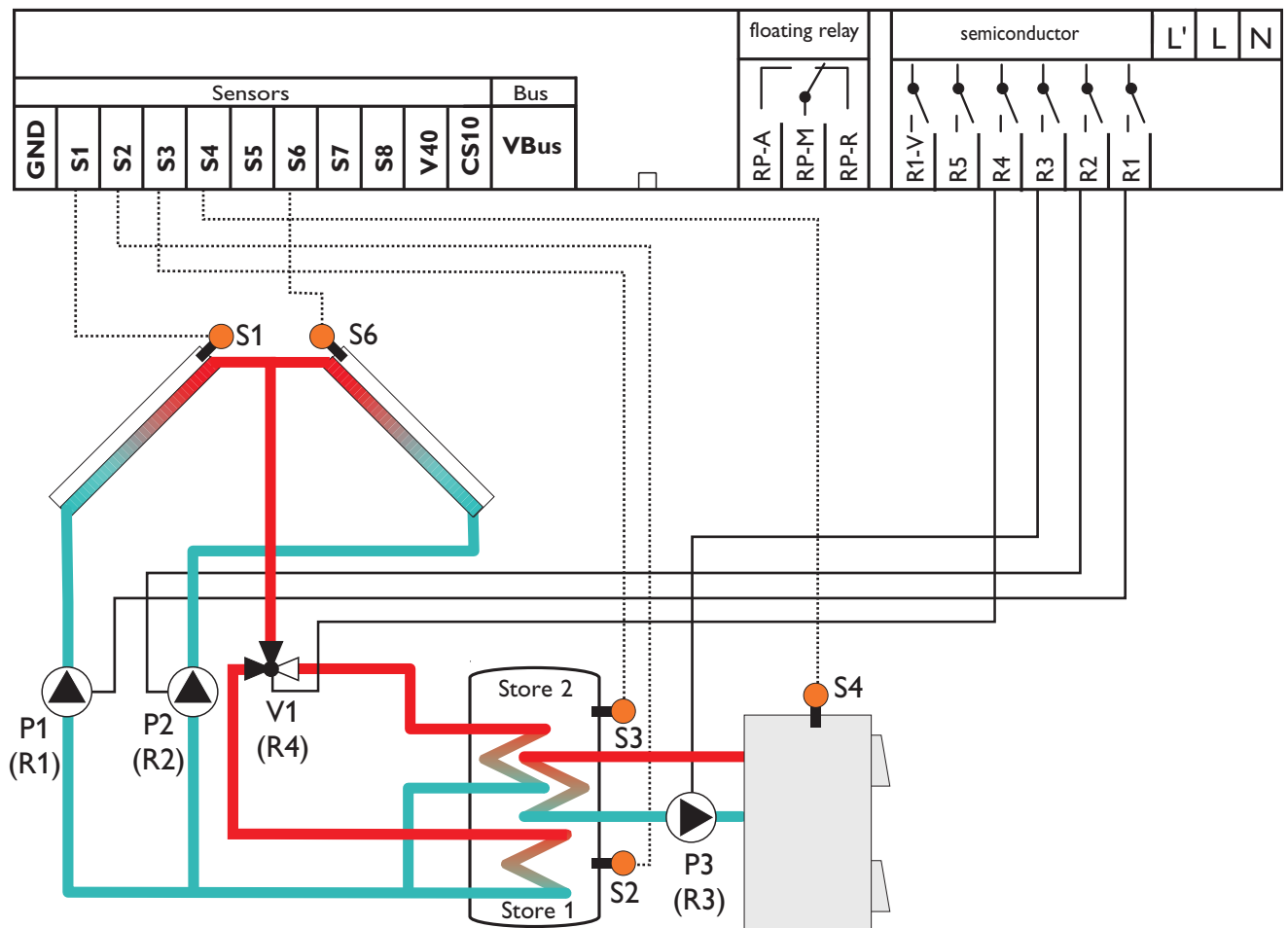

Note: 3-port valve V1 normally open - store base

Relay output	Note
R1	solar pump (P1) with speed control
R2	Solar pump (P2) with speed control
R3	domestic hot water afterheating (P3)
R4	3-port valvel (V1) store top/base
R5	
RP-R	
RP-M	
RP-A	

Sensor input	description
S1	temperature collector 1
S2	temperature store base
S3	temperature store top
S6	temperature collector 2
CS10 (optional)	irradiation

chan-nel	description	factory setting	change to	note
COL1	temperature collector 1	-----		
TSTL	temperature store base	-----		
TSTU	temperature store top	-----		
TSFB	temperature solid fuel boiler	-----		
COL2	temperature collector 2	-----		
IRR	irradiation	-----		
n1 %	speed relay 1	-----		
n2 %	speed relay 2	-----		
n3 %	speed relay 3	-----		
h P1	operating hours relay 1	-----		
h P2	operating hours relay 2	-----		
h P3	operating hours relay 3	-----		
TIME	time	-----		Adjust the actual clock time.
Arr	arrangement choice	1	26	Arrangement 26: 2-collector-system (east-/west collectors) multi-layer store system with domestic hot water afterheating by solid fuel boiler
DT1O	switch-on temperature difference 1	6.0 K		Adjust the desired switch-on temperature difference for store 1 Note: This value applies to collector 1 and 2
DT1F	switch-off temperature difference 1	4.0 K		Adjust the desired switch-off temperature difference for store 1 Note: This value applies to collector 1 and 2
DT1S	set temperature difference 1	10.0 K		Adjust the desired set temperature difference for store 1. Note: This value applies to collector 1 and 2
RIS1	rise 1	2 K		If the adjusted temperature difference DT1S is reached and if the temperature increases by the difference RIS1, the speed will be increased by 10% respectively. Note: This value applies to collector 1 and 2
S1MX	maximum temperature store 1	60 °C		Adjust the desired maximum temperature for store 1
DT2O	switch-on temperature difference 2	6.0 K		Adjust the desired switch-on temperature difference for store 2. Note: This value applies to collector 1 and 2
DT2F	switch-off temperature difference 2	4.0 K		Adjust the desired switch-off temperature difference for store 2 Note: This value applies to collector 1 and 2
DT2S	set temperature difference 2	10.0 K		Adjust the desired set temperature difference for store 2. Note: This value applies to collector 1 and 2
RIS2	rise 2	2 K		If the adjusted temperature difference DT2S is reached and if the temperature increases by the difference RIS2, the speed will be increased by 10% respectively. Note: This value applies to collector 1 and 2
S2MX	maximum temperature store 2	60 °C		Adjust the desired maximum store temperature for store 2



chan-nel	description	factory setting	change to	note
EM1	emergency temperature collector 1	140 °C		Adjust this value to 200°C when the collector emergency shutdown function should not start.
OCX1	option collector cooling collector 1	OFF		
OCN1	option minimum limitation collector 1	OFF		
OCF1	option frost protection collector 1	OFF		
EM2	emergency temperature collector 2	140 °C		Adjust this value to 200°C when the collector emergency shutdown function should not start.
OCX2	option collector cooling collector 2	OFF		
OCN2	option minimum limitation collector 2	OFF		
OCF2	option frost protection collector 2	OFF		
PRIO	priority	2		priority store top
tST	break time	2 Min.		The loading break time for the priority logic function can be changed (see appendix priority logic)
tRUN	runtime	15 Min.		The oscillating loading time for the priority logic function can be changed (see appendix priority logic)
OREC	option recooling	OFF		
OTC	option tube collector	OFF		
DT3O	switch-on temperature difference 3	6.0 K		Adjust the desired switch-on temperature difference for solid fuel boiler pump
DT3F	switch-off temperature difference 3	4.0 K		Adjust the desired switch-off temperature difference for solid fuel boiler pump
DT3S	set temperature DT3	10.0 K		Adjust the desired set temperature difference for store charging pump solid fuel boiler
RIS3	rise DT3	2 K		If the adjusted temperature difference DT3S is reached and if the temperature increases by the difference RIS3, speed relay 3 will be increased by 10% respectively.
MX3O	switch-on threshold for maximum temperature	60,0		Adjust the desired maximum store temperature for switching of the solid fuel burner pump (P3) Note: If the maximum store temperature (MX3O) at sensor S3 is reached, pump P3 is switched off. When the store temperature falls below MX3F at S3, the pump is switched-on again.
MX3F	switch-off threshold for maximum temperature	58.0 °C		
MN3O	switch-on threshold for minimum temperature	60,0		Adjust the desired minimum temperature for releasing pump P3 Note: Pump P3 is switched on when the solid fuel boiler (S4) reaches 65 °C (MN3F) and when there is a temperature difference (DT3O) to store sensor S3. It is switched off when the temperature of the solid fuel boiler falls to 60 °C (MN3O), the temperature difference falls below the switch-off temperature difference (DT3F) or when the store maximum temperature (MX3O) at sensor S3 is reached.
MN3F	switch-off threshold for minimum temperature	65.0 °C		
OHQM	option heat quantity measurement	OFF		

chan- nel	description	factory setting	change to	note
<b>CS 10</b>	solar irradiation sensor	<b>5</b>		
<b>n1MN</b>	minimum speed relay 1	<b>30</b>		
<b>n2MN</b>	minimum speed relay 2	<b>30</b>		
<b>n3MN</b>	minimum speed relay 3	<b>30</b>		
<b>HND1</b>	manual operation relay 1	<b>AUTO</b>		
<b>HND2</b>	manual operation relay 2	<b>AUTO</b>		
<b>HND3</b>	manual operation relay 3	<b>AUTO</b>		
<b>HND4</b>	manual operation relay 4	<b>AUTO</b>		
<b>HND5</b>	manual operation relay 5	<b>AUTO</b>		
<b>HND6</b>	manual operation relay 6	<b>AUTO</b>		
<b>LANG</b>	language	<b>dE</b>		<b>dE = German En = English It = Italian Fr = French</b>
<b>PROG</b>	program number	<b>xx.xx</b>		
<b>VERS</b>	version number	<b>x.xx</b>		

Information on priority logic can be found on page 115.

## System Arrangement 27

### System description:

The controller compares the temperatures at the collector sensors S1 and S6 to the store temperatures at the store sensors S2 and S3. If one of the measured temperature differences is higher than the adjusted switch-on differences, the corresponding pump (P1, P2) is switched on and the corresponding store zone is loaded up to the maximum temperature at most via the valve (V1). The priority logic

causes priority loading of the upper zone of the store. With another temperature differential function (S3 heat source / S5 heat sink) heating circuit return preheating is possible via V2.

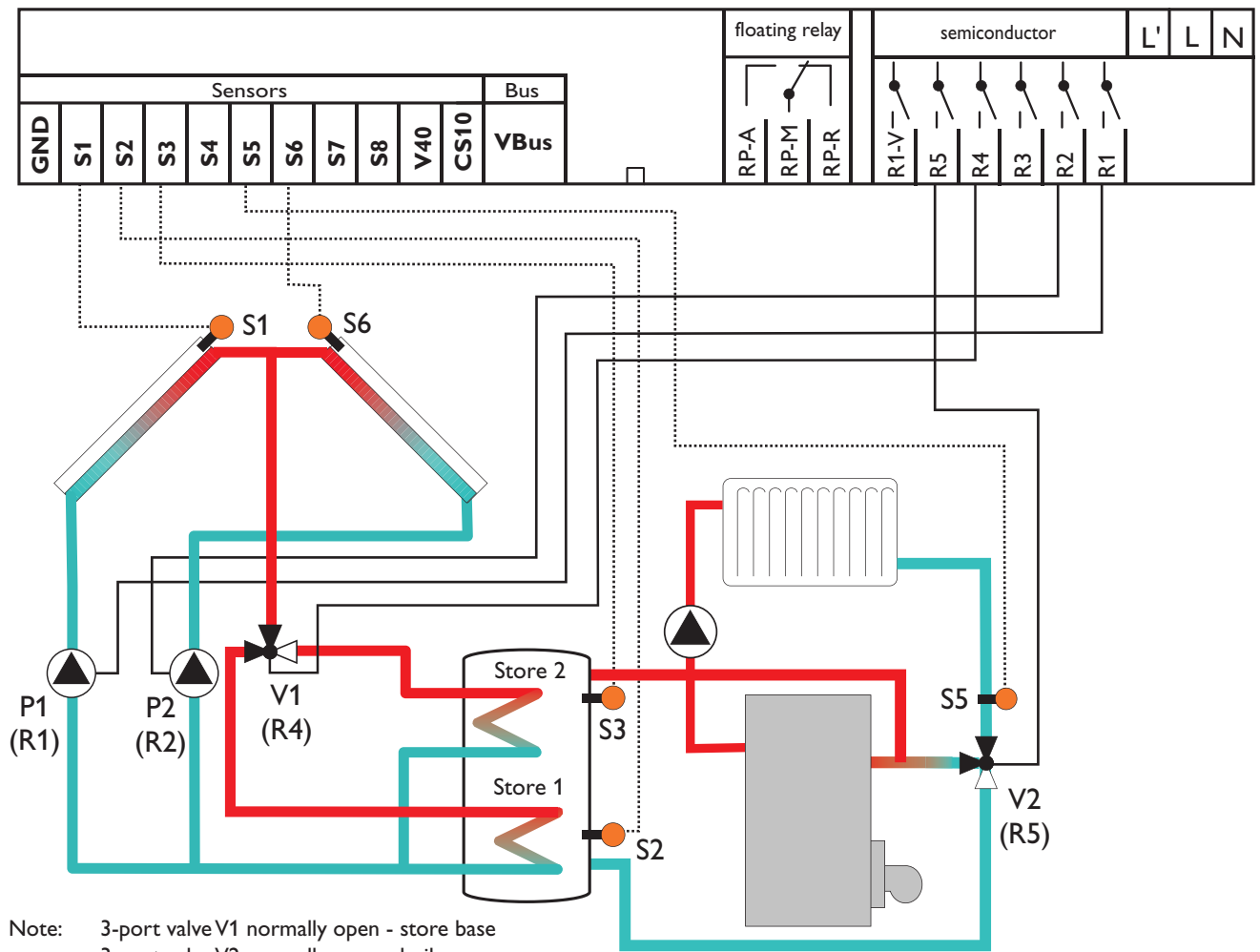

Relay output	Note
R1	solar pump (P1) with speed control
R2	solar pump (P2) with speed control
R3	
R4	3-port valve (V1) store top/base
R5	3-port valve (V2) heating circuit return preheating
RP-R	
RP-M	
RP-A	

Sensor input	description
S1	temperature collector 1
S2	temperature store base
S3	temperature store top
S5	temperature heating circuit
S6	temperature collector 2
CS10 (optional)	irradiation

chan- nel	description	factory setting	change to	note
COL1	temperature collector 1	-----		
TSTL	temperature store base	-----		
TSTU	temperature store top	-----		
TREC	temperature heating circuit	-----		
COL2	temperature collector 2	-----		
IRR	irradiation	-----		
n1 %	speed relay 1	-----		
n2 %	speed relay 2	-----		
h P1	operating hours relay 1	-----		
h P2	operating hours relay 2	-----		
TIME	time	-----		Adjust the actual clock time.
Arr	arrangement choice	1	27	Arrangement 27: 2-collector-system (east-/west collectors) multi-layer store system with heating circuit return preheating
DT1O	switch-on temperature difference 1	6.0 K		Adjust the desired switch-on temperature difference for store 1. Note: This value applies to collector 1 and 2
DT1F	switch-off temperature difference 1	4.0 K		Adjust the desired switch-off temperature difference for store 1. Note: This value applies to collector 1 and 2
DT1S	set temperature difference 1	10.0 K		Adjust the desired set temperature difference for store 1. Note: This value applies to collector 1 and 2
RIS1	rise 1	2 K		If the adjusted temperature difference DT1S is reached and if the temperature increases by the difference RIS1, the speed will be increased by 10% respectively. This value applies to collector 1 and 2
S1MX	maximum temperature store 1	60 °C		Adjust the desired maximum store temperature for store 1.
DT2O	switch-on temperature difference 2	6.0 K		Adjust the desired switch-on temperature difference for store 2. Note: This value applies to collector 1 and 2
DT2F	switch-off temperature difference 2	4.0 K		Adjust the desired switch-off temperature difference for store 2. Note: This value applies to collector 1 and 2
DT2S	set temperature difference 2	10.0 K		Adjust the desired set temperature difference for store 2. Note: This value applies to collector 1 and 2
RIS2	rise 2	2 K		If the adjusted temperature difference DT2S is reached and if the temperature increases by the difference RIS2, the speed will be increased by 10% respectively. Note: This value applies to collector 1 and 2
S2MX	maximum temperature store 2	60 °C		Adjust the desired maximum store temperature for store 2.
EM1	emergency temperature collector 1	140 °C		Adjust this value to 200°C when the collector emergency shutdown function should not start.
OCX1	option collector cooling collector 1	OFF		
OCN1	option minimum limitation collector 1	OFF		

chan- nel	description	factory setting	change to	note
OCF1	option frost protection collector 1	OFF		
EM2	emergency temperature collector 2	140 °C		Adjust this value to 200°C when the collector emergency shutdown function should not start.
OCX2	option collector cooling collector 2	OFF		
OCN2	option minimum limitation collector 2	OFF		
OCF2	option frost protection collector 2	OFF		
PRIO	priority	2		priority store top
tST	break time	2 Min.		The loading break time for the priority logic function can be changed (see appendix priority logic)
tRUN	runtime	15 Min.		The oscillating loading time for the priority logic function can be changed (see appendix priority logic)
OREC	option recooling	OFF		
OTC	option tube collector	OFF		
DT3O	switch-on temperature difference 3	6.0 K		Adjust the desired switch-on temperature difference for heating circuit return preheating (heating circuit backup)
DT3F	switch-off temperature difference 3	4.0 K		Adjust the desired switch-off temperature difference for heating circuit return preheating
OHQM	option heat quantity measurement	OFF		
CS 10	solar irradiation sensor	5		
n1MN	minimum speed relay 1	30		
n2MN	minimum speed relay 2	30		
HND1	manual operation relay 1	AUTO		
HND2	manual operation relay 2	AUTO		
HND3	manual operation relay 3	AUTO		
HND4	manual operation relay 4	AUTO		
HND5	manual operation relay 5	AUTO		
HND6	manual operation relay 6	AUTO		
LANG	language	dE		dE = German En = English It = Italian Fr = French
PROG	program number	xx.xx		
VERS	version number	x.xx		

Information on priority logic can be found on page 115.

## System Arrangement 28

### System description:

The controller compares the temperatures at the collector sensors S1 and S6 to the store temperatures at the store sensors S2 and S3. If one of the measured temperature differences is higher than the adjusted switch-on differences, the corresponding pump (P1, P2) is switched on and the corresponding store zone is loaded up to the maximum temperature at most via valve (V1). The priority logic causes

priority loading of the upper zone of the store. With another temperature differential function (S3 heat source / S5 heat sink) heating circuit return preheating is possible via V2. With a thermostat function (S3) domestic hot water afterheating (P3) can be carried out.

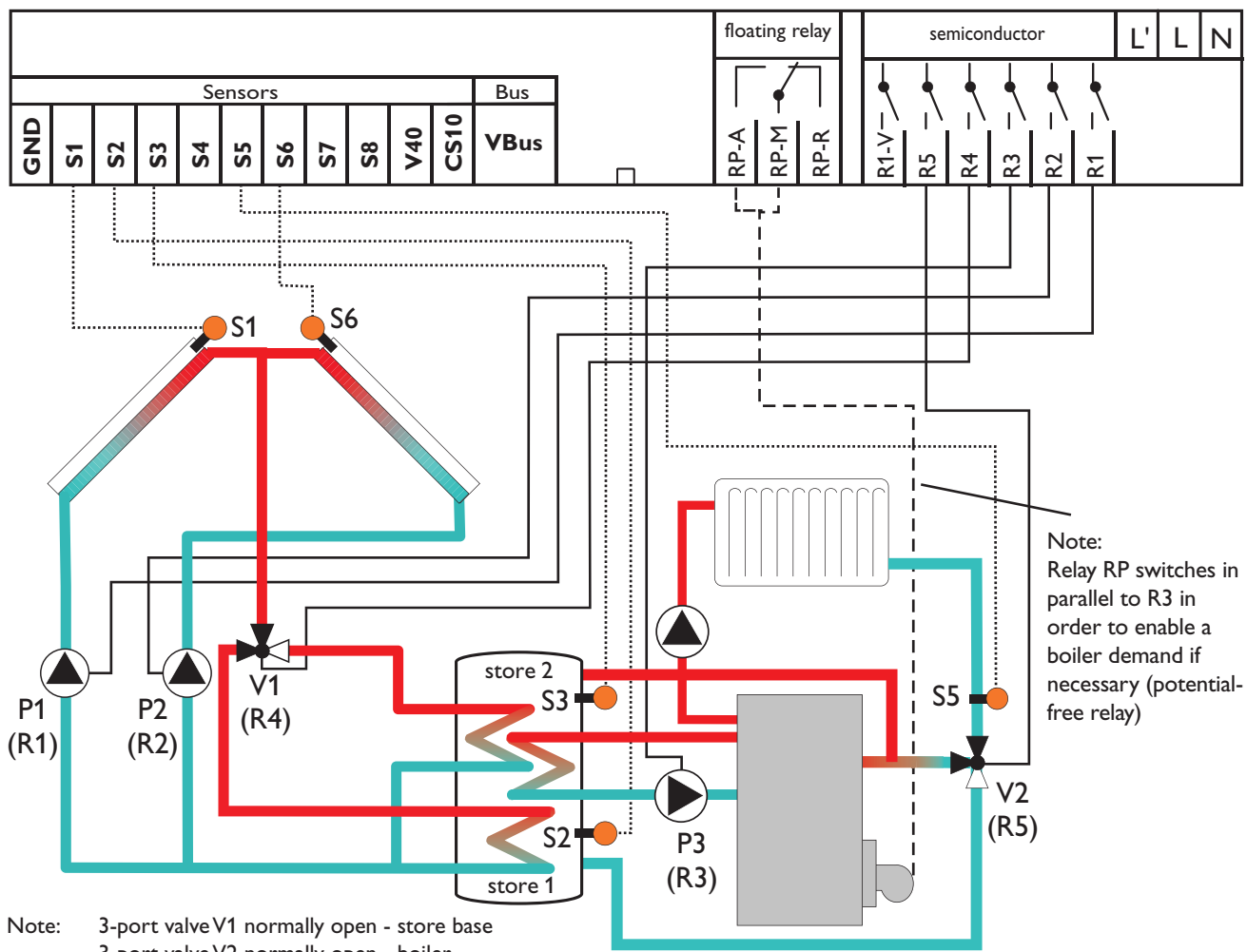

Relay output	Note
R1	solar pump (P1) with speed control
R2	solar pump (P2) with speed control
R3	charging pump domestic hot water afterheating (P3)
R4	3-port valve (V1) store top/base
R5	3-port valve (V2) heating circuit return preheating
RP-R	
RP-M	boiler demand (potential-free), is switched on in parallel to R3
RP-A	

Sensor input	description
S1	temperature collector 1
S2	temperature store base
S3	temperature store top
S5	temperature heating circuit
S6	temperature collector 2
CS10 (optional)	irradiation

channel	description	factory setting	change to	note
COL1	temperature collector 1	-----		
TSTL	temperature store base	-----		
TSTU	temperature store top	-----		
TREC	temperature heating circuit	-----		
COL2	temperature collector 2	-----		
IRR	irradiation	-----		
n1 %	speed relay 1	-----		
n2 %	speed relay 2	-----		
h P1	operating hours relay 1	-----		
h P2	operating hours relay 2	-----		
h P3	operating hours relay 3	-----		
TIME	time	-----		Adjust the actual clock time.
Arr	arrangement choice	1	28	Arrangement 27: 2 collector-system (east-/west collectors) multi-layer store system with heating circuit return preheating and domestic hot water afterheating
DT1O	switch-on temperature difference 1	6.0 K		Adjust the desired switch-on temperature difference for store 1. Note: This value applies to collector 1 and 2
DT1F	switch-off temperature difference 1	4.0 K		Adjust the desired switch-off temperature difference for store 1. Note: This value applies to collector 1 and 2
DT1S	set temperature difference 1	10.0 K		Adjust the desired set temperature difference for store 1. Note: This value applies to collector 1 and 2
RIS1	rise 1	2 K		If the adjusted temperature difference DT1S is reached and if the temperature increases by the difference RIS1, the speed will be increased by 10% respectively. Note: This value applies to collector 1 and 2
S1MX	maximum temperature store 1	60		Adjust the desired maximum temperature for store 1
DT2O	switch-on temperature difference 2	6.0 K		Adjust the desired switch-on temperature difference for store 2. Note: This value applies to collector 1 and 2
DT2F	switch-off temperature difference 2	4.0 K		Adjust the desired switch-off temperature difference for store 2. Note: This value applies to collector 1 and 2
DT2S	set temperature difference 2	10.0 K		Adjust the desired set temperature difference for store 2. Note: This value applies to collector 1 and 2
RIS2	rise 2	2 K		If the adjusted temperature difference DT2S is reached and if the temperature increases by the difference RIS2, the speed will be increased by 10% respectively. Note: This value applies to collector 1 and 2
S2MX	maximum temperature store 2	60		Adjust the desired maximum store temperature for store 2
EM1	emergency temperature collector 1	140 °C		Adjust this value to 200°C when the collector emergency shutdown function should not start.

channel	description	factory setting	change to	note
OCX1	option collector cooling collector 1	OFF		
OCN1	option minimum limitation collector 1	OFF		
OCF1	option frost protection collector 1	OFF		
EM2	emergency temperature collector 2	140 °C		Adjust this value to 200°C when the collector emergency shutdown function should not start.
OCX2	option collector cooling collector 2	OFF		
OCN2	option minimum limitation collector 2	OFF		
OCF2	option frost protection collector 2	OFF		
PRIO	priority	2		priority store top
tST	break time	2 Min.		The loading break time for the priority logic function can be changed (see appendix priority logic)
tRUN	runtime	15 Min.		The oscillating loading time for the priority logic function can be changed (see appendix priority logic)
OREC	option recooling	OFF		
OTC	option tube collector	OFF		
DT3O	switch-on temperature difference 3	6.0 K		Adjust the desired switch-on temperature difference for heating circuit backup (heating circuit return preheating)
DT3F	switch-off temperature difference 3	4.0 K		Adjust the desired switch-off temperature difference for heating circuit return preheating (heating circuit backup)
NH O	switch-on temperature thermostat 1	40.0 °C		Adjust the desired switch-on temperature difference for domestic hot water afterheating
NH F	switch-off temperature thermostat 1	45.0 °C		Adjust the desired switch-off temperature for domestic hot water afterheating
t1 O	time frame 1 switch-on temperature	00:00		Up to 3 additional time frames can be selected for the thermostat function (DHW afterheating). The thermostat function (DHW afterheating) will be activated within these time frames only. Example: If the thermostat function (DHW afterheating) should run between 06:00 a.m. and 08:00 a.m.; and 06:00 p.m. and 07:00 p.m., adjust t1 O to 06:00 a.m., t1 F to 08:00 a.m., t2 O to 06:00 p.m. and t2 F to 07:00 p.m. When all time frames are set to 00:00, the thermostat function (DHW afterheating) is always activated (factory setting).
t1 F	time frame 1 switch-off temperature	00:00		
t2 O	time frame 2 switch-on temperature	00:00		
t2 F	time frame 2 switch-off temperature	00:00		
t3 O	time frame 3 switch-on temperature	00:00		



channel	description	factory setting	change to	note
t3 F	time frame 3 switch-off temperature	00:00		
OHQM	option heat quantity measurement	OFF		
n1MN	minimum speed relay 1	30		
n2MN	minimum speed relay 2	30		
HND1	manual operation relay 1	AUTO		
HND2	manual operation relay 2	AUTO		
HND3	manual operation relay 3	AUTO		
HND4	manual operation relay 4	AUTO		
HND5	manual operation relay 5	AUTO		
HND6	manual operation relay 6	AUTO		
LANG	language	dE		dE = German En = English It = Italian Fr = French
PROG	program number	xx.xx		
VERS	version number	x.xx		

Information on priority logic can be found on page 115.

## System Arrangement 29

### System description:

The controller compares the temperatures at the collector sensors S1 and S6 to the temperatures at sensors S2 and S4. If one of the measured temperature differences is higher than the adjusted switch-on differences, the corresponding pump (P1, P2) is switched on and the corresponding store

is loaded up to the maximum temperature at most via valve (V1). Sensors S3 can optionally be connected for measurement purposes.

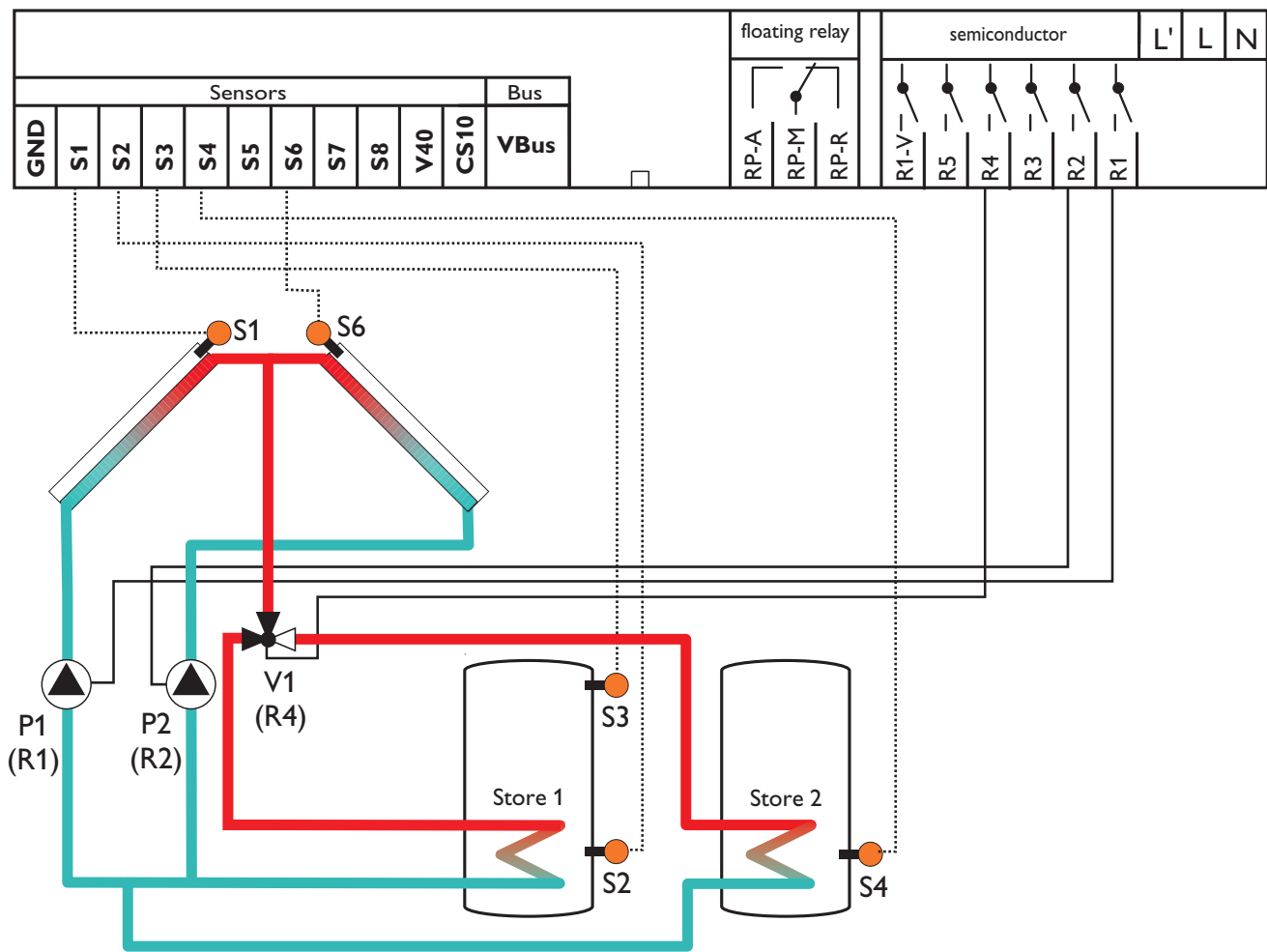

Note: 3-port valve V1 normally open - store 1

Relay output	Note
R1	solar pump (P1) with speed control
R2	solar pump (P2) with speed control
R3	
R4	3-port valve (V1) store 1 / 2
R5	
RP-R	
RP-M	
RP-A	

Sensor input	description
S1	temperature collector 1
S2	temperature store 1 base
S3	temperature store 1 top (sensor)
S4	temperature store 2 base
CS10 (optional)	irradiation

channel	description	factory setting	change to	note
COL1	temperature collector 1	-----		
TST1	temperature store 1 base	-----		
TSTU	temperature store 1 top	-----		
TST2	temperature store 2 base	-----		
COL2	temperature collector 2	-----		
IRR	irradiation	-----		
n1 %	speed relay 1	-----		
n2 %	speed relay 2	-----		
h P1	operating hours relay 1	-----		
h P2	operating hours relay 2	-----		
TIME	time	-----		Adjust the actual clock time.
Arr	arrangement choice	1	29	Arrangement 29: 2-collector- (east-/west collectors), 2-store system
DT1O	switch-on temperature difference 1	6.0 K		Adjust the desired switch-on temperature difference for store 1. Note: This value applies to collector 1 and 2
DT1F	switch-off temperature difference 1	4.0 K		Adjust the desired switch-off temperature difference for store 1. Note: This value applies to collector 1 and 2
DT1S	set temperature difference 1	10.0 K		Adjust the desired set temperature difference for store 1. Note: This value applies to collector 1 and 2
RIS1	rise 1	2 K		If the adjusted temperature difference DT1S is reached and if the temperature increases by the difference RIS1, the speed will be increased by 10% respectively. Note: This value applies to collector 1 and 2
S1MX	maximum temperature store 1	60 °C		Adjust the desired maximum store temperature for store 1.
DT2O	switch-on temperature difference 2	6.0 K		Adjust the desired switch-on temperature difference for store 2. Note: This value applies to collector 1 and 2
DT2F	switch-off temperature difference 2	4.0 K		Adjust the desired switch-off temperature difference for store 2. Note: This value applies to collector 1 and 2
DT2S	set temperature difference 2	10.0 K		Adjust the desired set temperature difference for store 2. Note: This value applies to collector 1 and 2
RIS2	rise 2	2 K		If the adjusted temperature difference DT2S is reached and if the temperature increases by the difference RIS2, the speed will be increased by 10% respectively. Note: This value applies to collector 1 and 2
S2MX	maximum temperature store 2	60		Adjust the desired maximum store temperature for store 2.
EM1	emergency temperature collector 1	140 °C		Adjust this value to 200°C when the collector emergency shutdown function should not start.
OCX1	option collector cooling collector 1	OFF		
OCN1	option minimum limitation collector 1	OFF		

channel	description	factory setting	change to	note
OCF1	option frost protection collector 1	OFF		
EM2	emergency temperature collector 2	140 °C		Adjust this value to 200°C when the collector emergency shutdown function should not start.
OCX2	option collector cooling collector 2	OFF		
OCN2	option minimum limitation collector 2	OFF		
OCF2	option frost protection collector 2	OFF		
PRIO	priority	1		priority store 1, subordinate store 2
tST	break time	2 Min.		The loading break time for the priority logic function can be changed (see appendix priority logic)
tRUN	runtime	15 Min.		The oscillating loading time for the priority logic function can be changed (see appendix priority logic)
OREC	option recooling	OFF		
OTC	option tube collector	OFF		
OHQM	option heat quantity measurement	OFF		
CS 10	solar irradiation sensor	5		
n1MN	minimum speed relay 1	30		
n2MN	minimum speed relay 2	30		
HND1	manual operation relay 1	AUTO		
HND2	manual operation relay 2	AUTO		
HND3	manual operation relay 3	AUTO		
HND4	manual operation relay 4	AUTO		
HND5	manual operation relay 5	AUTO		
HND6	manual operation relay 6	AUTO		
LANG	language	dE		dE = German En = English It = Italian Fr = French
PROG	program number	xx.xx		
VERS	version number	x.xx		

Information on priority logic can be found on page 115.

## System Arrangement 30

### System description:

The controller compares the temperatures at the collector sensors S1 and S6 to the store temperature at S2 and S4. If one of the measured temperature differences is higher than the adjusted switch-on differences, the corresponding pump (P1, P2) is switched on and the corresponding store is loaded up to the maximum temperature at most

via valve (V1).

Heat transfer control to store 2 (P2) can be carried out using another temperature differential function (S3 heat source/S4 heat sink).

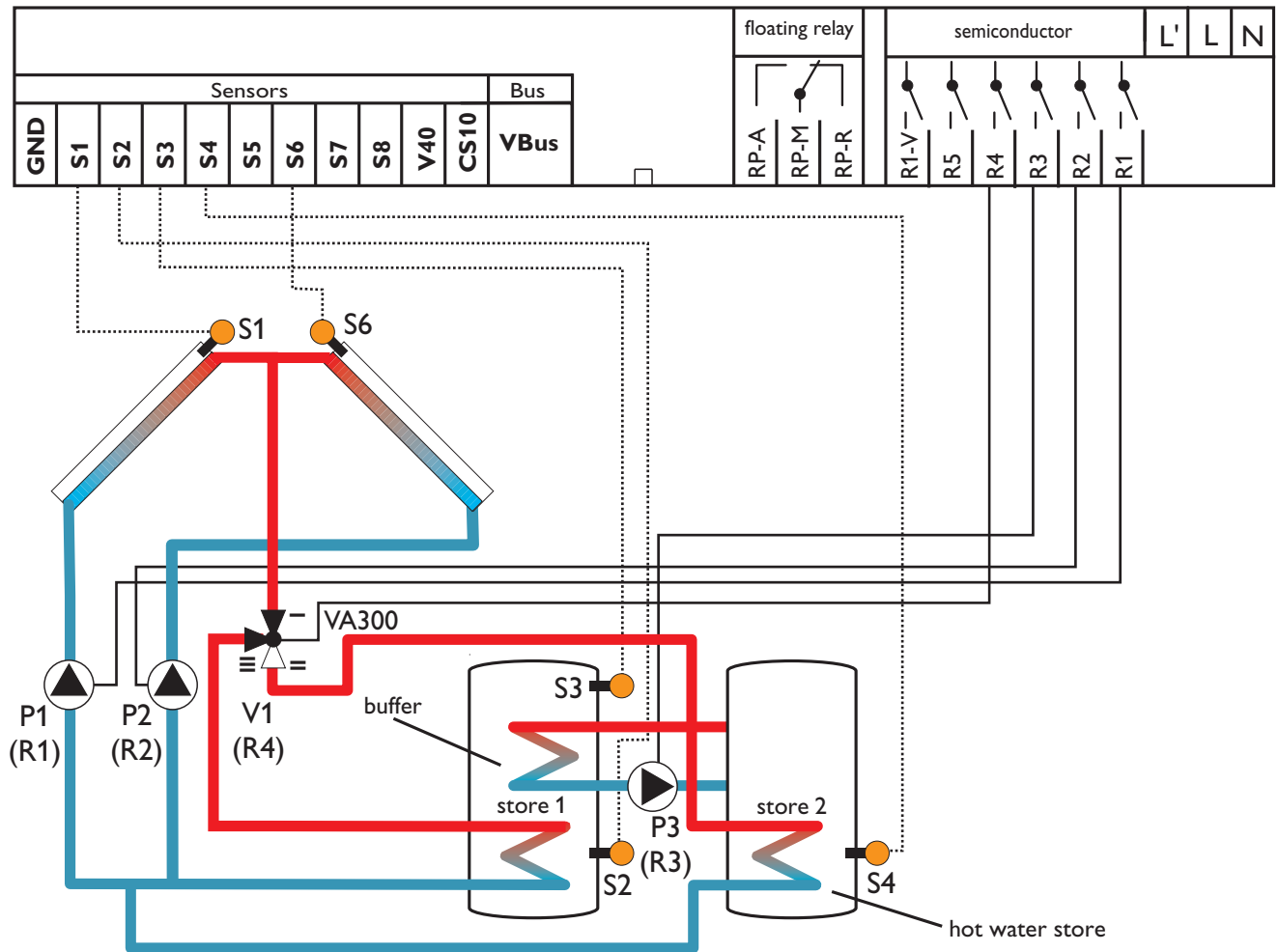

Note: 3-port valve V1 normally open - store 1

Relay output	Note
R1	solar pump (P1) with speed control
R2	solar pump (P2) with speed control
R3	pump heat exchange (P3)
R4	3-port valve (V1) store 1 / 2
R5	
RP-R	
RP-M	
RP-A	

Sensor input	description
S1	temperature collector 1
S2	temperature store 1 base
S3	temperature store 1 top (sensor)
S4	temperature store 2 base
CS10 (optional)	irradiation

channel	description	factory setting	change to	note
COL1	temperature collector 1	-----		
TST1	temperature store 1 base	-----		
TSTU	temperature store 1 top	-----		
TST2	temperature store 2 base	-----		
COL2	temperature collector 2	-----		
IRR	irradiation	-----		
n1 %	speed relay 1	-----		
n2 %	speed relay 2	-----		
n3 %	speed relay 3	-----		
h P1	operating hours relay 1	-----		
h P2	operating hours relay 2	-----		
h P3	operating hours relay 3			
TIME	time	-----		Adjust the actual clock time.
Arr	arrangement choice	1	30	Arrangement 30: 2-collector- (east-/west collectors), 2-store system with heat exchange control
DT1O	switch-on temperature difference 1	6.0 K		Adjust the desired switch-on temperature difference for store 1. Note: This value applies to collector 1 and 2
DT1F	switch-off temperature difference 1	4.0 K		Adjust the desired switch-off temperature difference for store 1. Note: This value applies to collector 1 and 2
DT1S	set temperature difference 1	10.0 K		Adjust the desired set temperature difference for store 1. Note: This value applies to collector 1 and 2
RIS1	rise 1	2 K		If the adjusted temperature difference DT1S is reached and if the temperature increases by the difference RIS1, the speed will be increased by 10% respectively. Note: This value applies to collector 1 and 2
S1MX	maximum temperature store 1	60 °C		Adjust the desired maximum store temperature for store 1.
DT2O	switch-on temperature difference 2	6.0 K		Adjust the desired switch-on temperature difference for store 2. Note: This value applies to collector 1 and 2
DT2F	switch-off temperature difference 2	4.0 K		Adjust the desired switch-off temperature difference for store 2. Note: This value applies to collector 1 and 2
DT2S	set temperature difference 2	10.0 K		Adjust the desired set temperature difference for store 2. Note: This value applies to collector 1 and 2
RIS2	rise 2	2 K		If the adjusted temperature difference DT2S is reached and if the temperature increases by the difference RIS2, the speed will be increased by 10% respectively. Note: This value applies to collector 1 and 2
S2MX	maximum temperature store 2	60 °C		Adjust the desired maximum store temperature for store 2.
EM1	emergency temperature collector 1	140 °C		Adjust this value to 200°C when the collector emergency shutdown function should not start.

channel	description	factory setting	change to	note
OCX1	option collector cooling collector 1	OFF		
OCN1	option minimum limitation collector 1	OFF		
OCF1	option frost protection collector 1	OFF		
EM2	emergency temperature collector 2	140 °C		Adjust this value to 200°C when the collector emergency shutdown function should not start.
OCX2	option collector cooling collector 2	OFF		
OCN2	option minimum limitation collector 2	OFF		
OCF2	option frost protection collector 2	OFF		
PRIO	priority	1	2	Priority store 2 (hot water store), subordinate store 1 (buffer store)
tST	break time	2 Min.		The loading break time for the priority logic function can be changed (see appendix priority logic)
tRUN	runtime	15 Min.		The oscillating loading time for the priority logic function can be changed (see appendix priority logic)
OREC	option recooling	OFF		
OTC	option tube collector	OFF		
DT3O	switch-on temperature difference 3	6.0 K		Adjust the desired switch-on temperature difference for heat exchange control
DT3F	switch-off temperature difference 3	4.0 K		Adjust the desired switch-off temperature difference for heat exchange control
DT3S	set temperature DT3	10.0 K		Adjust the desired set temperature difference for heat exchange control
RIS3	rise DT3	2 K		If the adjusted temperature difference DT3S is reached and if the temperature increases by the difference RIS3, speed relay 3 (P3) will be increased by 10% respectively.
MX3O	switch-on threshold for maximum temp.	60,0 °C		Adjust the desired maximum store temperature for the hot water store (referred to P3) Note: If the maximum store temperature (MX3O) at sensor S4 is reached, pump P3 is switched off. If the store temperature falls below MX3F at S4, the pump is switched-on again.
MX3F	switch-off threshold for maximum temperature	58.0 °C		
MN3O	switch-on threshold for minimum temperature	5,0		A minimum temperature for releasing pump P3 can be adjusted. If pump P3 should be released at a temperature identical to or higher than 60 °C in the buffer store (measured at S3), the following values have to be adjusted: MN3O = 55 °C; MN3F = 60 °C. The pump will then be released if 60 °C has been reached and will be blocked again if the temperature falls below 55 °C.
MN3F	switch-off threshold for minimum temperature	10.0 °C		
OHQM	option heat quantity measurement	OFF		

channel	description	factory setting	change to	note
n1MN	minimum speed relay 1	30		
n2MN	minimum speed relay 2	30		
n3MN	minimum speed relay 3	30		
HND1	manual operation relay 1	AUTO		
HND2	manual operation relay 2	AUTO		
HND3	manual operation relay 3	AUTO		
HND4	manual operation relay 4	AUTO		
HND5	manual operation relay 5	AUTO		
HND6	manual operation relay 6	AUTO		
LANG	language	dE		dE = German En = English It = Italian Fr = French
PROG	program number	xx.xx		
VERS	version number	x.xx		

Information on priority logic can be found on page 115.



## System Arrangement 31

### System description:

The controller calculates the temperature difference between collector sensor S1 and store sensor S2. If the difference is larger than or identical to the adjusted switch-on temperature difference, pump (P1) will be switched on and the store will be loaded until the switch-off temperature difference or the maximum store temperature is reached. With another temperature differential function (S4 heat source / S5 heat sink) heating circuit return preheating

(heating circuit backup) is possible via V1. With a thermostat function (S3) domestic hot water afterheating (P2) can be carried out.

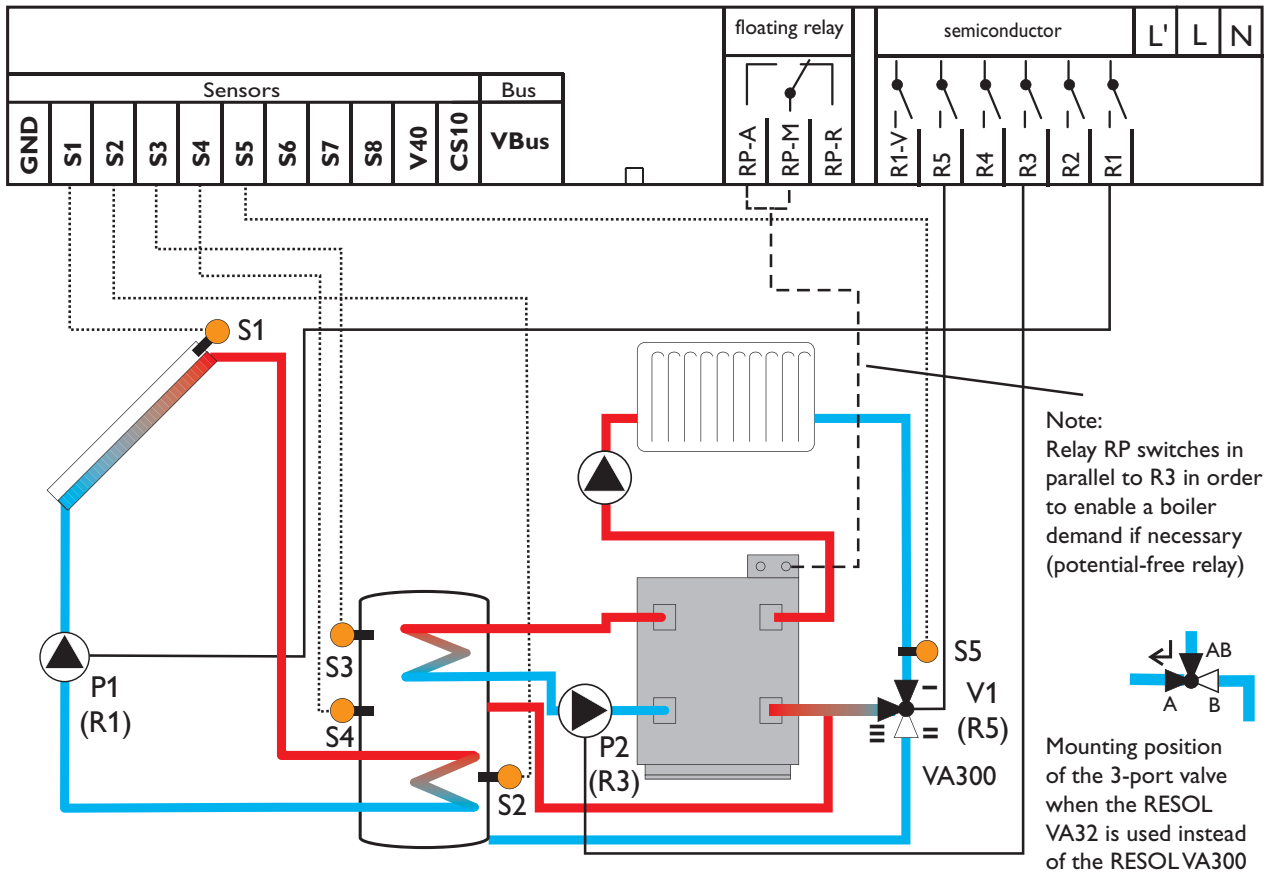

Relay output	Note
R1	solar pump (P1) with speed control
R2	
R3	pump - domestic hot water afterheating (P2)
R4	
R5	3-port valve (V1) heating circuit return preheating
RP-R	
RP-M	boiler demand (potential-free), is switched on in parallel to R3
RP-A	

Sensor input	description
S1	temperature collector
S2	temperature store base
S3	temperature store top
S4	temperature middle of the store (heat source - return preheating)
S5	temperature heating circuit
CS10 (optional)	irradiation

channel	description	factory setting	change to	note
COL	temperature collector	-----		
TSTL	temperature store base	-----		
TSTU	temperature store top	-----		
S4	temperature middle of the store	-----		
TREC	temperature return temperature sensor	-----		
IRR	irradiation	-----		
n %	speed relay	-----		
h P	operating hours solar - pump	-----		
h P	flow rate	-----		
TIME	time	-----		Adjust the actual clock time.
Arr	arrangement choice	1	31	Arrangement 31: 1-store system with heating circuit return preheating and domestic hot water afterheating
DT O	switch-on temperature difference	6.0 K		Adjust the desired switch-on temperature difference
DT F	switch-off temperature difference	4.0 K		Adjust the desired switch-off temperature difference
DT S	set temperature difference	10.0 K		Adjust the desired set temperature difference
RIS	rise	2 K		If the adjusted temperature difference DTS is reached and if the temperature increases by the difference RIS, the speed will be increased by 10% respectively.
S MX	maximum store temperature	60		Adjust the desired maximum store temperature
EM	collector emergency temperature	140 °C		Adjust this value to 200°C when the collector emergency shutdown function should not start.
OCX	Option collector cooling	OFF		
OCN	Option minimum limitation	OFF		
OCF	Option frost protection	OFF		
OREC	option recooling	OFF		
OTC	option tube collector	OFF		
DT3O	switch-on temperature difference 3	6.0 K		Adjust the desired switch-on temperature difference for heating circuit return preheating.
DT3F	switch-off temperature difference 3	4.0 K		Adjust the desired switch-off temperature difference for heating circuit return preheating
NH O	switch-on temperature thermostat 1	40.0 °C		Adjust the desired switch-on temperature difference for domestic hot water afterheating
NH F	switch-off temperature thermostat 1	45.0 °C		Adjust the desired switch-off temperature difference for domestic hot water afterheating

channel	description	factory setting	change to	note
t1 O	time frame 1 switch-on temperature	00:00		Up to 3 additional time frames can be selected for the thermostat function (DHW afterheating). The thermostat function (DHW afterheating) will be activated within these time frames only. Example: If the thermostat function should run from 06:00 a.m. and 08:00 a.m.; and 06:00 p.m. and 07:00 p.m. only, adjust t1O to 06:00 a.m., t1F to 08:00 a.m., t2O to 06:00 p.m. and t2F to 07:00 p.m.. When all time frames are set to 00:00, the thermostat function (DHW afterheating) is always activated (factory setting).
t1 F	time frame 1 switch-off temperature	00:00		
t2 O	time frame 2 switch-on temperature	00:00		
t2 F	time frame 2 switch-off temperature	00:00		
t3 O	time frame 3 switch-on temperature	00:00		
t3 F	time frame 3 switch-off temperature	00:00		
OHQM	option heat quantity measurement	OFF		
CS 10	solar irradiation sensor	5		
n MN	minimum speed relay 1	30		
HND1	manual operation relay 1	AUTO		
HND2	manual operation relay 2	AUTO		
HND3	manual operation relay 3	AUTO		
HND4	manual operation relay 4	AUTO		
HND5	manual operation relay 5	AUTO		
HND6	manual operation relay 6	AUTO		
LANG	language	dE		dE = German En = English It = Italian Fr = French
PROG	program number	xx.xx		
VERS	version number	x.xx		

## System Arrangement 32

### System description:

The controller compares the temperature at sensor S1 to the temperatures at sensors S2 and S3. If the measured temperature differences are higher than the adjusted switch-on temperature differences, the pump (P1) will be activated and the corresponding store zone will be loaded up to the adjusted maximum temperature at most via the valve (V1).

The priority logic causes priority loading of the upper zone of the store.

With another temperature differential function (S4 heat source / S5 heat sink) heating circuit return preheating is possible via V2.

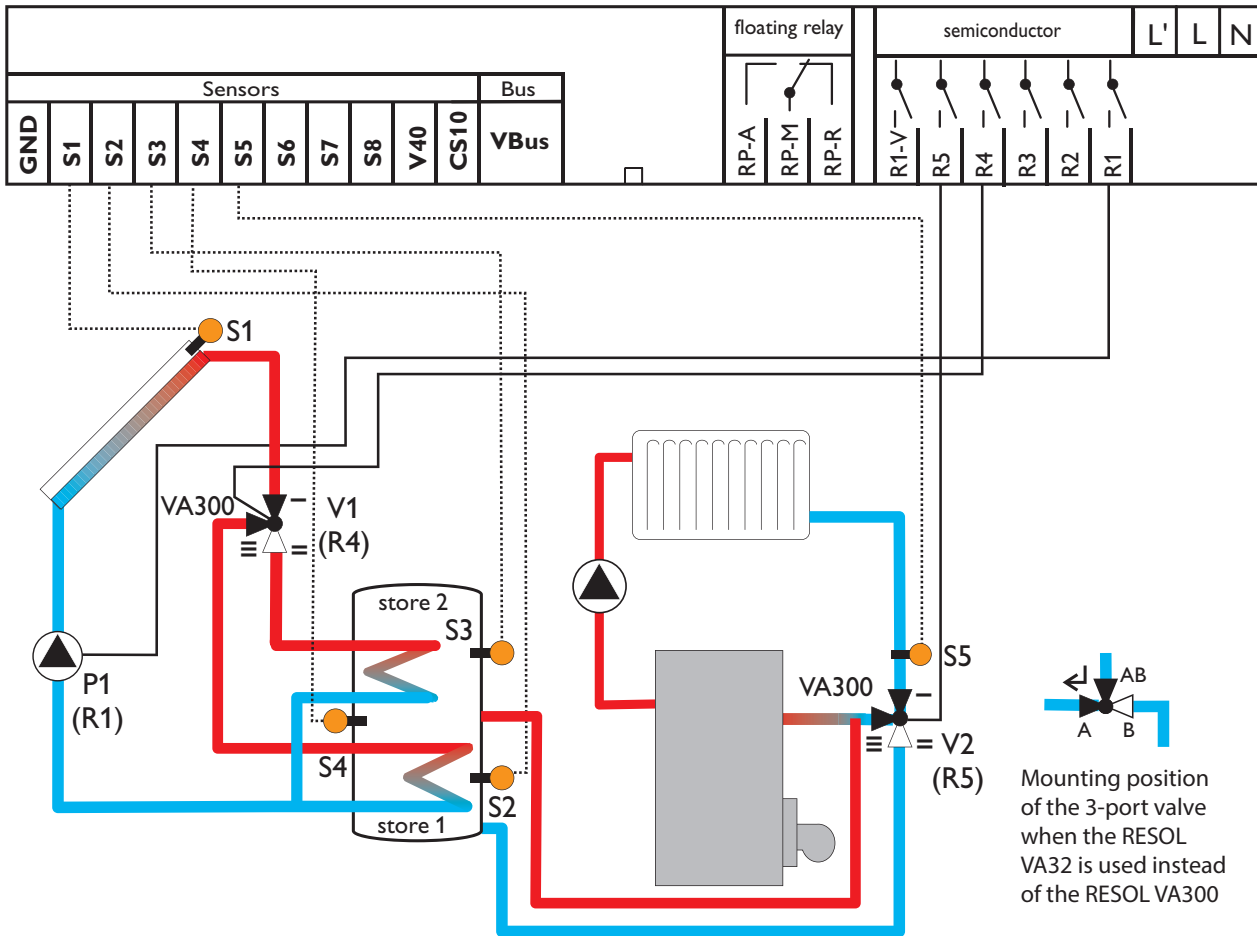

**Note:**  
3-port valve V1 normally open - store base

**Note:**  
3-port valve V2 normally open - boiler

Relay output	Note
R1	solar pump (P1) with speed control
R2	
R3	
R4	3-port valve (V1) store top/base
R5	3-port valve (V2) heating circuit return preheating

Sensor input	description
S1	temperature collector
S2	temperature store base
S3	temperature store top
S4	temperature middle of the store (heat source - return preheating)
S5	temperature heating circuit
CS10 (optional)	irradiation

channel	description	factory setting	change to	note
COL	temperature collector	-----		
TSTL	temperature store base	-----		
TSTU	temperature store 1 top	-----		
S4	temperature middle of the store	-----		
TREC	temperature heating circuit	-----		
IRR	irradiation	-----		
n %	speed relay	-----		
h P	operating hours relay	-----		
TIME	time	-----		Adjust the actual clock time.
Arr	arrangement choice	1	32	Arrangement 32: Multi-layer store system with heating circuit return preheating
DT1O	switch-on temperature difference 1	6.0 K		Adjust the desired switch-on temperature difference for store 1.
DT1F	switch-off temperature difference 1	4.0 K		Adjust the desired switch-off temperature difference for store 1.
DT1S	set temperature difference 1	10.0 K		Adjust the desired set temperature difference for store 1.
RIS1	rise 1	2 K		If the adjusted temperature difference DT1S is reached and if the temperature increases by the difference RIS1, the speed will be increased by 10% respectively.
S1MX	maximum temperature store 1	60 °C		Adjust the desired maximum store temperature for store 1.
DT2O	switch-on temperature difference 2	6.0 K		Adjust the desired switch-on temperature difference for store 2.
DT2F	switch-off temperature difference 2	4.0 K		Adjust the desired switch-off temperature difference for store 2.
DT2S	set temperature difference 2	10.0 K		Adjust the desired set temperature difference for store 2.
RIS2	rise 2	2 K		If the adjusted temperature difference DT2S is reached and if the temperature increases by the difference RIS2, the speed will be increased by 10% respectively.
S2MX	maximum temperature store 2	60 °C		Adjust the desired maximum store temperature for store 2.
EM	collector emergency temperature	140 °C		Adjust this value to 200°C when the collector emergency shutdown function should not start.
OCX	Option collector cooling	OFF		
OCN	Option minimum limitation	OFF		
OCF	Option frost protection	OFF		
PRIO	priority	2		priority store top
tST	break time	2 Min.		The loading break time for the priority logic function can be changed (see appendix priority logic)
tRUN	runtime	15 Min.		The oscillating loading time for the priority logic function can be changed (see appendix priority logic)
OREC	option recooling	OFF		
OTC	option tube collector	OFF		
DT3O	switch-on temperature difference 3	6.0 K		Adjust the desired switch-on temperature difference for heating circuit return preheating.

channel	description	factory setting	change to	note
DT3F	switch-off temperature difference 3	4.0 K		Adjust the desired switch-off temperature difference for heating circuit return preheating
OHQM	option heat quantity measurement	OFF		
CS 10	solar irradiation sensor	5		
n MN	minimum speed relay 1	30		
HND1	manual operation relay 1	AUTO		
HND2	manual operation relay 2	AUTO		
HND3	manual operation relay 3	AUTO		
HND4	manual operation relay 4	AUTO		
HND5	manual operation relay 5	AUTO		
HND6	manual operation relay 6	AUTO		
LANG	language	dE		dE = German En = English It = Italian Fr = French
PROG	program number	xx.xx		
VERS	version number	x.xx		

## System Arrangement 33

### System description:

The controller compares the temperature at sensor S1 to the temperatures at sensors S2 and S3. If the measured temperature differences are higher than the adjusted switch-on temperature differences, the pump (P1) will be activated and the corresponding store zone will be loaded up to the adjusted maximum temperature at most via the valve (V1). The priority logic causes priority loading of the upper zone

of the store.

With another temperature differential function (S4 heat source / S5 heat sink) heating circuit return preheating is possible via V2. With a thermostat function (S3) domestic hot water afterheating (P2) can be carried out.

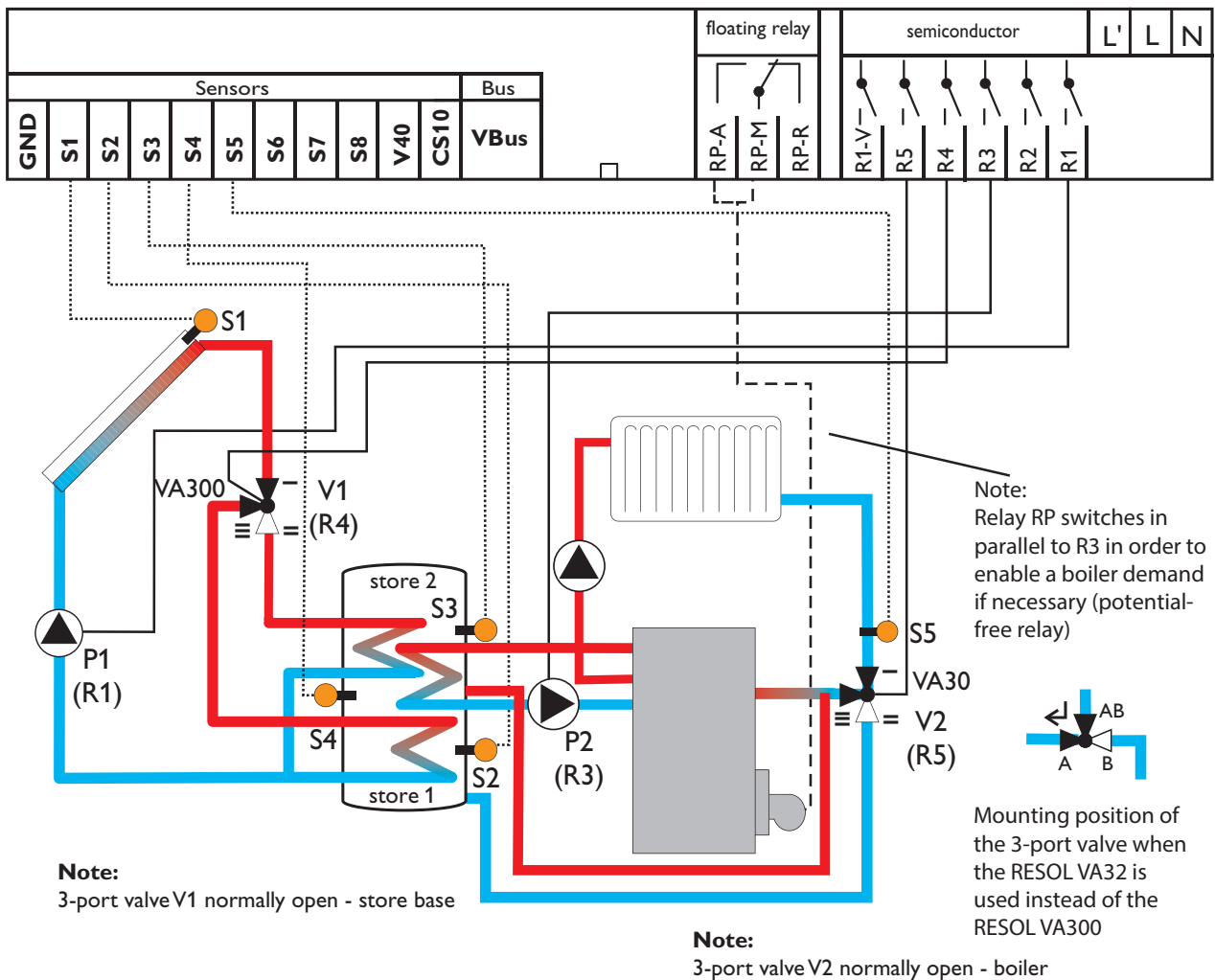

Relay output	Note
R1	solar pump (P1) with speed control
R2	
R3	domestic hot water afterheating (P2)
R4	3-port valve (V1) store top/base
R5	3-port valve (V1) heating circuit return preheating
RP-R	
RP-M	boiler demand (potential-free), is
RP-A	switched on in parallel to R3

Sensor input	description
S1	temperature collector
S2	temperature store base
S3	temperature store top
S4	temperature middle of the store (heat source - return preheating)
S5	temperature heating circuit (heat sink - return preheating)
CS10 (optional)	irradiation

channel	description	factory setting	change to	note
COL	temperature collector	-----		
TSTL	temperature store base	-----		
TSTU	temperature store top	-----		
S4	temperature middle of the store	-----		
TREC	temperature heating circuit	-----		
IRR	irradiation	-----		
n %	speed relay	-----		
h P	operating hours relay	-----		
h P3	operating hours relay 3	-----		
TIME	time	-----		Adjust the actual clock time.
Arr	arrangement choice	1	33	Arrangement 33: Multi-layer store system with heating circuit return preheating and DHW afterheating
DT1O	switch-on temperature difference 1	6.0 K		Adjust the desired switch-on temperature difference for store 1.
DT1F	switch-off temperature difference 1	4.0 K		Adjust the desired switch-off temperature difference for store 1.
DT1S	set temperature difference 1	10.0 K		Adjust the desired set temperature difference for store 1.
RIS1	rise 1	2 K		If the adjusted temperature difference DT1S is reached and if the temperature increases by the difference RIS1, the speed will be increased by 10% respectively.
S1MX	maximum temperature store 1	60 °C		Adjust the desired maximum store temperature for store 1.
DT2O	switch-on temperature difference 2	6.0 K		Adjust the desired switch-on temperature difference for store 2.
DT2F	switch-off temperature difference 2	4.0 K		Adjust the desired switch-off temperature difference for store 2.
DT2S	set temperature difference 2	10.0 K		Adjust the desired set temperature difference for store 2.
RIS2	rise 2	2 K		If the adjusted temperature difference DT2S is reached and if the temperature increases by the difference RIS2, the speed will be increased by 10% respectively.
S2MX	maximum temperature store 2	60 °C		Adjust the desired maximum store temperature for store 2.
EM	collector emergency temperature	140 °C		Adjust this value to 200°C when the collector emergency shutdown function should not start.
OCX	Option collector cooling	OFF		
OCN	Option minimum limitation	OFF		
OCF	Option frost protection	OFF		
PRIO	priority	2		priority store top
tST	break time	2 Min.		The loading break time for the priority logic function can be changed (see appendix priority logic)
tRUN	runtime	15 Min.		The oscillating loading time for the priority logic function can be changed (see appendix priority logic)
OREC	option recooling	OFF		
OTC	option tube collector	OFF		
DT3O	switch-on temperature difference 3	6.0 K		Adjust the desired switch-on temperature difference for heating circuit return preheating.
DT3F	switch-off temperature difference 3	4.0 K		Adjust the desired switch-off temperature difference for heating circuit return preheating
NH O	switch-on temperature thermostat 1	40.0 °C		Adjust the desired switch-on temperature difference for domestic hot water afterheating
NH F	switch-off temperature thermostat 1	45.0 °C		Adjust the desired switch-off temperature difference for domestic hot water afterheating



channel	description	factory setting	change to	note
t1 O	time frame 1 switch-on temperature	00:00		Up to 3 additional time frames can be selected for the thermostat function (DHW afterheating). The thermostat function (DHW afterheating) will be activated within these time frames only. Example: If the thermostat function (DHW afterheating) should run between 06:00 a.m. and 08:00 a.m.; and 06:00 p.m. and 07:00 p.m., adjust t1 O to 06:00 a.m., t1 F to 08:00 a.m., t2 O to 06:00 p.m. and t2 F to 07:00 p.m. When all time frames are set to 00:00, the thermostat function (DHW afterheating) is always activated (factory setting).
t1 F	time frame 1 switch-off temperature	00:00		
t2 O	time frame 2 switch-on temperature	00:00		
t2 F	time frame 2 switch-off temperature	00:00		
t3 O	time frame 3 switch-on temperature	00:00		
t3 F	time frame 3 switch-off temperature	00:00		
OHQM	option heat quantity measurement	OFF		
CS 10	solar irradiation sensor	5		
n MN	minimum speed relay 1	30		
HND1	manual operation relay 1	AUTO		
HND2	manual operation relay 2	AUTO		
HND3	manual operation relay 3	AUTO	33	
HND4	manual operation relay 4	AUTO		
HND5	manual operation relay 5	AUTO		
HND6	manual operation relay 6	AUTO		
LANG	language	dE		dE = German En = English It = Italian Fr = French
PROG	program number	xx.xx		
VERS	version number	x.xx		

## System Arrangement 34

### System description:

The controller compares the temperatures at the collector sensors S1 and S6 to the store temperature at store sensor S2. If one of the measured temperature differences is higher than the adjusted switch-on temperature differences, the corresponding pump (P1, P2) will be activated and the store will be loaded. With another temperature differential func-

tion (S4 heat source / S5 heat sink) heating circuit return preheating (heating circuit backup) is possible via V1. With a thermostat function (S3) domestic hot water afterheating (P3) can be carried out.

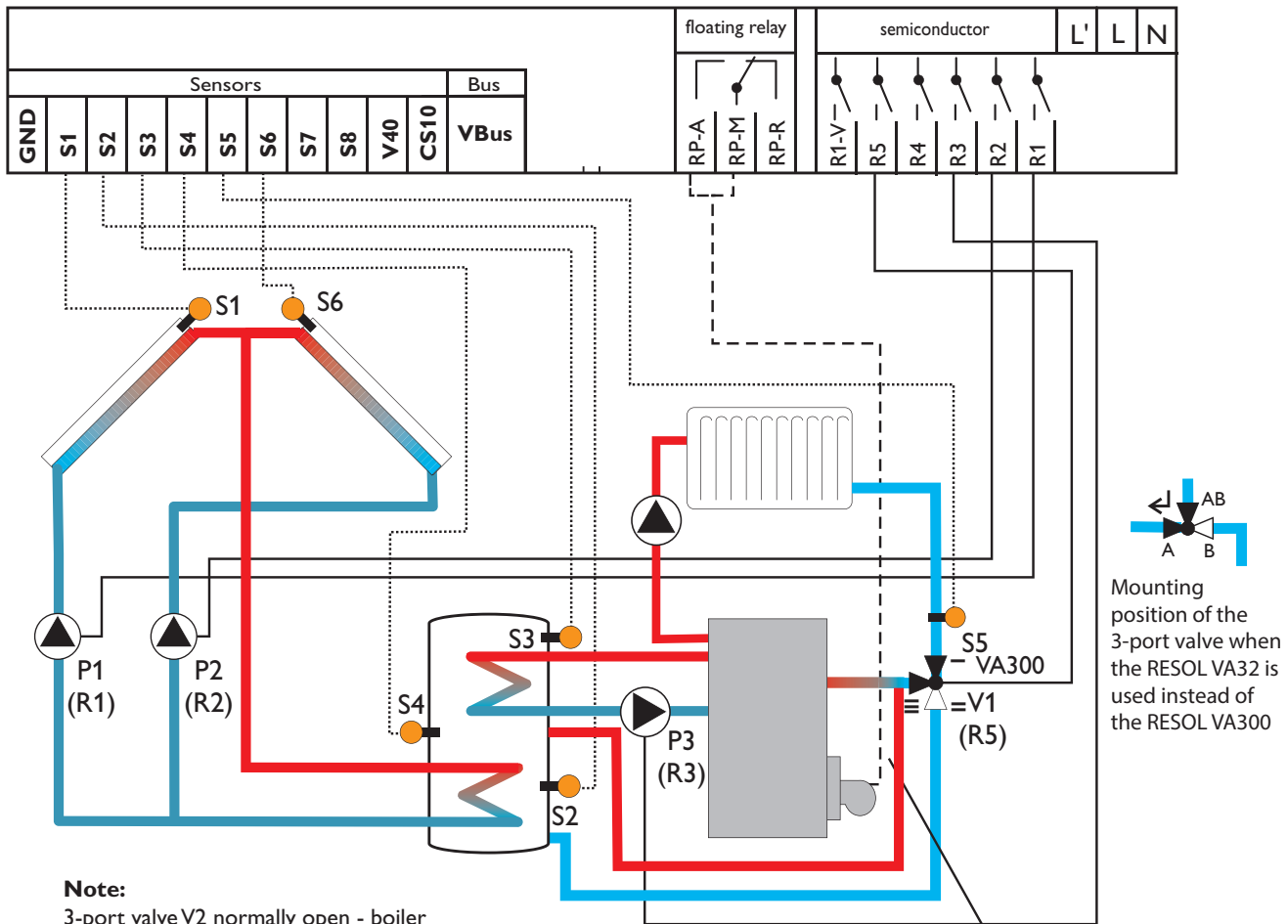

**Note:**  
3-port valve V2 normally open - boiler

**Note:**  
Relay RP switches in parallel to R3 in order to enable a boiler demand if necessary (potential-free relay)

Relay output	Note
R1	solar pump (P1) with speed control
R2	solar pump (P2) with speed control
R3	pump - domestic hot water afterheating (P3)
R4	
R5	3-port valve (V2) heating circuit return preheating
RP-R	
RP-M	boiler demand (potential-free), is switched on in parallel to R3
RP-A	

Sensor input	description
S1	temperature collector
S2	temperature store base
S3	temperature store top
S4	temperature middle of the store (heat source - return preheating)
S5	temperature heating circuit
S6	temperature collector 2
CS10 (optional)	irradiation

channel	description	factory setting	change to	note
COL1	temperature collector 1	-----		
TSTL	temperature store base	-----		
TSTU	temperature store 1 top	-----		
S4	temperature middle of the store	-----		
TREC	temperature heating circuit	-----		
COL2	temperature collector 2	-----		
IRR	irradiation	-----		
n1 %	speed relay 1	-----		
n2 %	speed relay 2	-----		
h P1	operating hours relay 1	-----		
h P2	operating hours relay 2	-----		
h P3	operating hours relay 3	-----		
TIME	time	-----		Adjust the actual clock time.
Arr	arrangement choice	1	34	Arrangement 34: 2-collector-system (east-/west collectors) with 1 store, heating circuit return preheating and domestic hot water afterheating
DT O	switch-on temperature difference	6.0 K		Adjust the desired switch-on temperature difference. Note: This value applies to collector 1 and 2
DT F	switch-off temperature difference	4.0 K		Adjust the desired switch-off temperature difference. Note: This value applies to collector 1 and 2
DT S	set temperature difference	10.0 K		Adjust the desired set temperature difference. Note: This value applies to collector 1 and 2
RIS	rise	2 K		If the adjusted temperature difference DTS is reached and if the temperature increases by the difference RIS, the speed will be increased by 10% respectively. This values applies to collector 1 and 2
S MX	maximum store temperature	60 °C		Adjust the desired maximum store temperature
EM1	emergency temperature collector 1	140 °C		Adjust this value to 200°C when the collector emergency shutdown function should not start.
OCX1	option collector cooling collector 1	OFF		
OCN1	option minimum limitation collector 1	OFF		
OCF1	option frost protection collector 1	OFF		
EM2	emergency temperature collector 2	140 °C		Adjust this value to 200°C when the collector emergency shutdown function should not start.
OCX2	option collector cooling collector 2	OFF		
OCN2	option minimum limitation collector 2	OFF		
OCF2	option frost protection collector 2	OFF		
OREC	option recooling	OFF		
OTC	option tube collector	OFF		
DT3O	switch-on temperature difference 3	6.0 K		Adjust the desired switch-on temperature difference for heating circuit return preheating.
DT3F	switch-off temperature difference 3	4.0 K		Adjust the desired switch-off temperature difference for heating circuit return preheating

channel	description	factory setting	change to	note
NH O	switch-on temperature thermostat 1	40.0 °C		Adjust the desired switch-on temperature for domestic hot water afterheating
NH F	switch-off temperature thermostat 1	45.0 °C		Adjust the desired switch-off temperature for domestic hot water afterheating
EM1	emergency temperature collector 1	140 °C		Adjust this value to 200°C when the collector emergency shutdown function should not start.
OCX1	option collector cooling collector 1	OFF		
OCN1	option minimum limitation collector 1	OFF		
OCF1	option frost protection collector 1	OFF		
EM2	emergency temperature collector 2	140 °C		Adjust this value to 200°C when the collector emergency shutdown function should not start.
OCX2	option collector cooling collector 2	OFF		
OCN2	option minimum limitation collector 2	OFF		
OCF2	option frost protection collector 2	OFF		
OREC	option recooling	OFF		
OTC	option tube collector	OFF		
DT3O	switch-on temperature difference 3	6.0 K		Adjust the desired switch-on temperature difference for heating circuit return preheating.
DT3F	switch-off temperature difference 3	4.0 K		Adjust the desired switch-off temperature difference for heating circuit return preheating
NH O	switch-on temperature thermostat 1	40.0 °C		Adjust the desired switch-on temperature for domestic hot water afterheating
NH F	switch-off temperature thermostat 1	45.0 °C		Adjust the desired switch-off temperature for domestic hot water afterheating
t1 O	time frame 1 switch-on temperature	00:00		Up to 3 additional time frames can be selected for the thermostat function (DHW afterheating). The thermostat function (DHW afterheating) will be activated within these time frames only. Example: If the thermostat function (DHW afterheating) should run between 06:00 a.m. and 08:00 a.m.; and 06:00 p.m. and 07:00 p.m., adjust t1 O to 06:00 a.m., t1 F to 08:00 a.m., t2 O to 06:00 p.m. and t2 F to 07:00 p.m..When all time frames are set to 00:00, the thermostat function (DHW afterheating) is always activated (factory setting).
t1 F	time frame 1 switch-off temperature	00:00		
t2 O	time frame 2 switch-on temperature	00:00		
t2 F	time frame 2 switch-off temperature	00:00		
t3 O	time frame 3 switch-on temperature	00:00		
t3 F	time frame 3 switch-off temperature	00:00		

## System Arrangement 35

### System description:

The controller compares the temperatures at the collector sensors S1 and S6 to the store temperatures at the store sensors S2 and S3. If one of the measured temperature differences is higher than the adjusted switch-on differences, the corresponding pump (P1, P2) is switched on and the corresponding store zone is loaded up to the maximum

temperature at most via the valve (V1). The priority logic causes priority loading of the upper zone of the store. With another temperature differential function (S4 heat source / S5 heat sink) heating circuit return preheating is possible via V2.

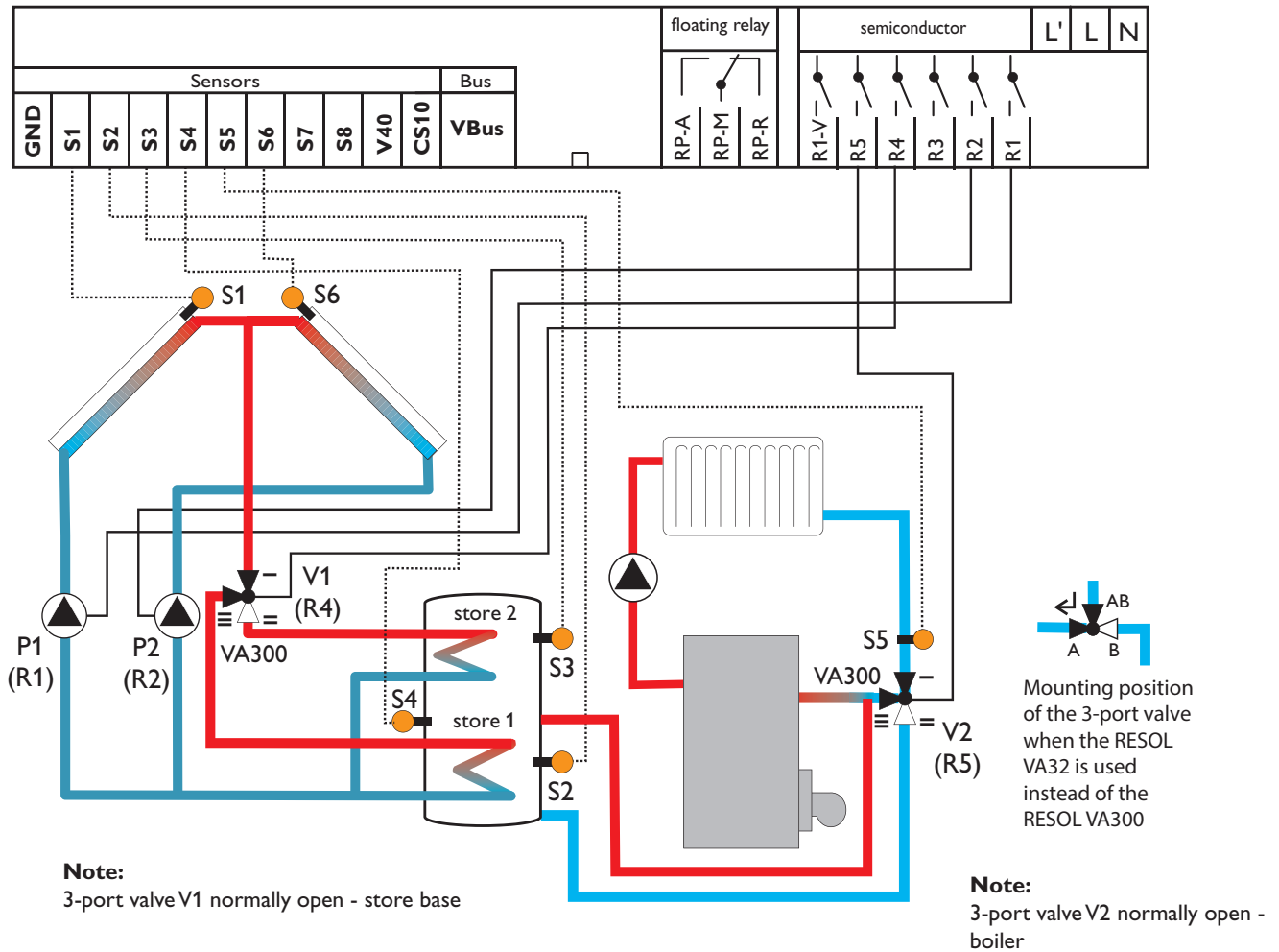

Relay output	Note
R1	solar pump (P1) with speed control
R2	solar pump (P2) with speed control
R3	
R4	3-port valve (V1) store top/base
R5	3-port valve (V2) heating circuit return preheating
RP-R	
RP-M	
RP-A	

Sensor input	description
S1	temperature collector 1
S2	temperature store base
S3	temperature store top
S4	temperature middle of the store (heat source - return preheating)
S5	temperature heating circuit
S6	temperature collector 2
CS10 (optional)	irradiation

chan-nel	description	factory setting	change to	note
COL1	temperature collector 1	-----		
TSTL	temperature store base	-----		
TSTU	temperature store top	-----		
S4	temperature middle of the store	-----		
TREC	temperature heating circuit	-----		
COL2	temperature collector 2	-----		
IRR	irradiation	-----		
n1 %	speed relay 1	-----		
n2 %	speed relay 2	-----		
h P1	operating hours relay 1	-----		
h P2	operating hours relay 2	-----		
TIME	time	-----		Adjust the actual clock time.
Arr	arrangement choice	1	35	Arrangement 35: 2-collector-system (east-/west collectors) multi-layer store system with heating circuit return preheating
DT1O	switch-on temperature difference 1	6.0 K		Adjust the desired switch-on temperature difference for store 1. Note: This value applies to collector 1 and 2
DT1F	switch-off temperature difference 1	4.0 K		Adjust the desired switch-off temperature difference for store 1. Note: This value applies to collector 1 and 2
DT1S	set temperature difference 1	10.0 K		Adjust the desired set temperature difference for store 1. Note: This value applies to collector 1 and 2
RIS1	rise 1	2 K		If the adjusted temperature difference DT1S is reached and if the temperature increases by the difference RIS1, the speed will be increased by 10% respectively. This value applies to collector 1 and 2
S1MX	maximum temperature store 1	60 °C		Adjust the desired maximum store temperature for store 1.
DT2O	switch-on temperature difference 2	6.0 K		Adjust the desired switch-on temperature difference for store 2. Note: This value applies to collector 1 and 2
DT2F	switch-off temperature difference 2	4.0 K		Adjust the desired switch-off temperature difference for store 2. Note: This value applies to collector 1 and 2
DT2S	set temperature difference 2	10.0 K		Adjust the desired set temperature difference for store 2. Note: This value applies to collector 1 and 2
RIS2	rise 2	2 K		If the adjusted temperature difference DT2S is reached and if the temperature increases by the difference RIS2, the speed will be increased by 10% respectively. Note: This value applies to collector 1 and 2
S2MX	maximum temperature store 2	60 °C		Adjust the desired maximum store temperature for store 2.
EM1	emergency temperature collector 1	140 °C		Adjust this value to 200 °C when the collector emergency shutdown function should not start.
OCX1	option collector cooling collector 1	OFF		
OCN1	option minimum limitation collector 1	OFF		
OCF1	option frost protection collector 1	OFF		
EM2	emergency temperature collector 2	140 °C		Adjust this value to 200 °C when the collector emergency shutdown function should not start.
OCX2	option collector cooling collector 2	OFF		

channel	description	factory setting	change to	note
OCN2	option minimum limitation collector 2	OFF		
OCF2	option frost protection collector 2	OFF		
PRIO	priority	2		priority store top
tST	break time	2 Min.		The loading break time for the priority logic function can be changed (see appendix priority logic)
tRUN	runtime	15 Min.		The oscillating loading time for the priority logic function can be changed (see appendix priority logic)
OREC	option recooling	OFF		
OTC	option tube collector	OFF		
DT3O	switch-on temperature difference 3	6.0 K		Adjust the desired switch-on temperature difference for heating circuit return preheating.
DT3F	switch-off temperature difference 3	4.0 K		Adjust the desired switch-off temperature difference for heating circuit return preheating
OHQM	option heat quantity measurement	OFF		
CS 10	solar irradiation sensor	5		
n1MN	minimum speed relay 1	30		
n2MN	minimum speed relay 2	30		
HND1	manual operation relay 1	AUTO		
HND2	manual operation relay 2	AUTO		
HND3	manual operation relay 3	AUTO		
HND4	manual operation relay 4	AUTO		
HND5	manual operation relay 5	AUTO		
HND6	manual operation relay 6	AUTO		
LANG	language	dE		dE = German En = English It = Italian Fr = French
PROG	program number	xx.xx		
VERS	version number	x.xx		

## System Arrangement 36

### System description:

The controller compares the temperatures at the collector sensors S1 and S6 to the store temperatures at the store sensors S2 and S3. If one of the measured temperature differences is higher than the adjusted switch-on differences, the corresponding pump (P1, P2) is switched on and the corresponding store zone is loaded up to the maximum

temperature at most via the valve (V1). The priority logic causes priority loading of the upper zone of the store. With another temperature differential function (S4 heat source / S5 heat sink) heating circuit return preheating is possible via V2. With a thermostat function (S3) domestic hot water afterheating (P3) can be carried out.

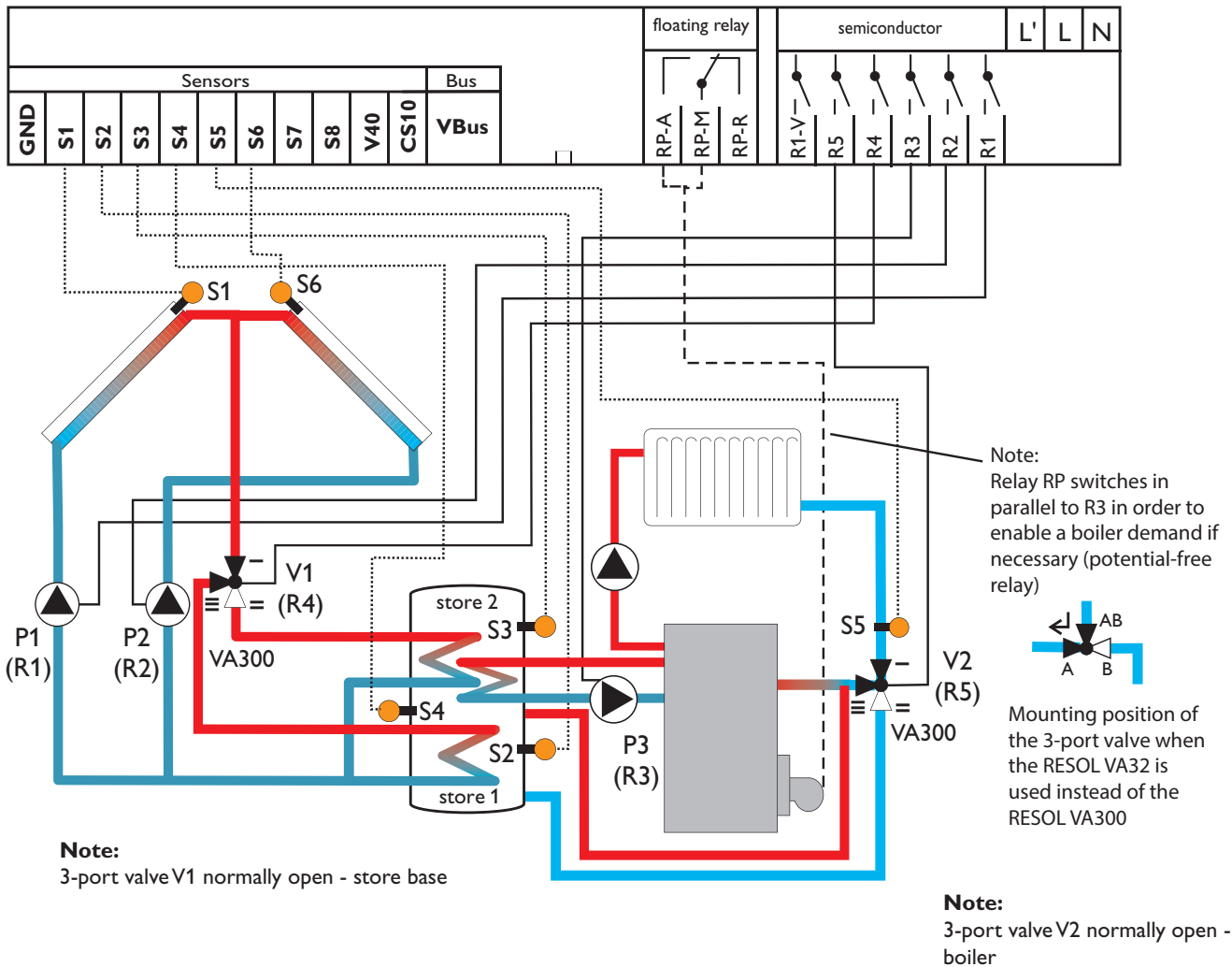

Relay output	Note
R1	solar pump (P1) with speed control
R2	solar pump (P2) with speed control
R3	pump - domestic hot water afterheating (P3)
R4	3-port valve (V1) store top/base
R5	3-port valve (V2) heating circuit return preheating
RP-R	
RP-M	boiler demand (potential-free), is switched on in parallel to R3
RP-A	

Sensor input	description
S1	temperature collector 1
S2	temperature store base
S3	temperature store top
S4	temperature middle of the store (heat source - return preheating)
S5	temperature heating circuit
S6	temperature collector 2
CS10 (optional)	irradiation



channel	description	factory setting	change to	note
COL1	temperature collector 1	-----		
TSTL	temperature store base	-----		
TSTU	temperature store top	-----		
S4	temperature middle of the store	-----		
TREC	temperature heating circuit	-----		
COL2	temperature collector 2	-----		
IRR	irradiation	-----		
n1 %	speed relay 1	-----		
n2 %	speed relay 2	-----		
h P1	operating hours relay 1	-----		
h P2	operating hours relay 2	-----		
h P3	operating hours relay 3	-----		
TIME	time	-----		Adjust the actual clock time.
Arr	arrangement choice	1	36	Arrangement 36: 2-collector- (east-/west collectors) and multi-layer store system with heating circuit return preheating and domestic hot water afterheating
DT1O	switch-on temperature difference 1	6.0 K		Adjust the desired switch-on temperature difference for store 1. Note: This value applies to collector 1 and 2
DT1F	switch-off temperature difference 1	4.0 K		Adjust the desired switch-off temperature difference for store 1. Note: This value applies to collector 1 and 2
DT1S	set temperature difference 1	60 °C		Adjust the desired set temperature difference for store 1. Note: This value applies to collector 1 and 2
RIS1	rise 1	2 K		If the adjusted temperature difference DT1S is reached and if the temperature increases by the difference RIS1, the speed will be increased by 10% respectively. This value applies to collector 1 and 2
S1MX	maximum temperature store 1	60 °C		Adjust the desired maximum store temperature for store 1.
DT2O	switch-on temperature difference 2	6.0 K		Adjust the desired switch-on temperature difference for store 2. This value applies to collector 1 and 2
DT2F	switch-off temperature difference 2	4.0 K		Adjust the desired switch-off temperature difference for store 2. Note: This value applies to collector 1 and 2
DT2S	set temperature difference 2	10.0 K		Adjust the desired set temperature difference for store 2. Note: This value applies to collector 1 and 2
RIS2	rise 2	2 K		If the adjusted temperature difference DT2S is reached and if the temperature increases by the difference RIS2, the speed will be increased by 10% respectively. Note: This value applies to collector 1 and 2
S2MX	maximum temperature store 2	60 °C		Adjust the desired maximum store temperature for store 2.
EM1	emergency temperature collector 1	140 °C		Adjust this value to 200°C when the collector emergency shutdown function should not start.
OCX1	option collector cooling collector 1	OFF		
OCN1	option minimum limitation collector 1	OFF		
OCF1	option frost protection collector 1	OFF		

channel	description	factory setting	change to	note
OCF1	option frost protection collector 1	OFF		
EM2	emergency temperature collector 2	140 °C		Adjust this value to 200°C when the collector emergency shutdown function should not start.
OCX2	option collector cooling collector 2	OFF		
OCN2	option minimum limitation collector 2	OFF		
OCF2	option frost protection collector 2	OFF		
PRI O	priority	2		priority store top
tST	break time	2 Min.		The loading break time for the priority logic function can be changed (see appendix priority logic)
tRUN	runtime	15 Min.		The oscillating loading time for the priority logic function can be changed (see appendix priority logic)
OREC	option recooling	OFF		
OTC	option tube collector	OFF		
DT3O	switch-on temperature difference 3	6.0 K		Adjust the desired switch-on temperature difference for heating circuit return preheating.
DT3F	switch-off temperature difference 3	4.0 K		Adjust the desired switch-off temperature difference for heating circuit return preheating
NH O	switch-on temperature thermostat 1	40.0 °C		Adjust the desired switch-on temperature difference for domestic hot water afterheating
NH F	switch-off temperature thermostat 1	45.0 °C		Adjust the desired switch-off temperature difference for domestic hot water afterheating
t1 O	time frame 1 switch-on temperature	00:00		Up to 3 additional time frames can be selected for the thermostat function (DHW afterheating). The thermostat function (DHW afterheating) will be activated within these time frames only. Example: If the thermostat function (DHW afterheating) should run between 06:00 a.m. and 08:00 a.m.; and 06:00 p.m. and 07:00 p.m., adjust t1 O to 06:00 a.m., t1 F to 08:00 a.m., t2 O to 06:00 p.m. and t2 F to 07:00 p.m.. When all time frames are set to 00:00, the thermostat function (DHW afterheating) is always activated (factory setting).
t1 F	time frame 1 switch-off temperature	00:00		
t2 O	time frame 2 switch-on temperature	00:00		
t2 F	time frame 2 switch-off temperature	00:00		
t3 O	time frame 3 switch-on temperature	00:00		
t3 F	time frame 3 switch-off temperature	00:00		
OHQM	option heat quantity measurement	OFF		
CS 10	solar irradiation sensor	5		
OHQM	option heat quantity measurement	OFF		
CS 10	solar irradiation sensor	5		
OHQM	option heat quantity measurement	OFF		
CS 10	solar irradiation sensor	5		

channel	description	factory setting	change to	note
n1MN	minimum speed relay 1	30		
n2MN	minimum speed relay 2	30		
HND1	manual operation relay 1	AUTO		
HND2	manual operation relay 2	AUTO		
HND3	manual operation relay 3	AUTO		
HND4	manual operation relay 4	AUTO		
HND5	manual operation relay 5	AUTO		
HND6	manual operation relay 6	AUTO		
LANG	language	dE		dE = German En = English It = Italian Fr = French
PROG	program number	xx.xx		
VERS	version number	x.xx		

## Corresponding adjustment values:

	factory setting	adjustment range
priority [PRIO]	1*	0-2
loading break time [tST]	2 min.	1-30 min.
oscillating loading time [tCIRC]	15 min.	1-30 min.

\* In multi-layer store systems (e.g. ARR 4) factory setting PRIO = 2 (priority store top)

## The DeltaSol ES priority logic:

The options and parameters described above are used in multi-store systems only (ARR 4-6, 11-17, 23-30, 32-33 and 35-36).

### Priority:

If priority is set to 0, the stores with a temperature difference to the collector are loaded in parallel (parallel loading, available in ARRANGEMENT 6 and 17 only).

If priority is adjusted to 1-2 the priority store will be loaded as long as its switch-on conditions are fulfilled. The subordinate store will be loaded using store sequence control. If the adjusted maximum temperature of the priority store has been reached, the subordinate store will be loaded as long as its switch-on conditions are fulfilled.

### Loading break time [tST]/ oscillating loading time [tCIRC]/ collector rise temperature

The controller checks whether the stores can be loaded (switch-on difference). When the priority store cannot be loaded, the subordinate store is checked. If the subordinate store can be loaded, it will be loaded for the oscillating loading time [t-circ.]. After this period of time, the loading process stops. The controller monitors the increase in collector temperature. If it increases by the collector rise temperature [DT-Col 2 K, fixed value in the software] within the loading break time [t-st] the elapsed break time is set to 0. The break time starts again. As soon as a switch-on condition of the priority store is fulfilled, it will be loaded. If the switch-on condition of the priority store is not fulfilled, loading of the subordinate stores will be continued. If the priority store reaches its maximum temperature, oscillating loading will not be carried out.

## System with calorimeter

### System description:

The use of the integrated calorimeter [OHQM] will be explained in the following example [Arrangement 1]: The integrated calorimeter can be activated in all pre-programmed system schematics.

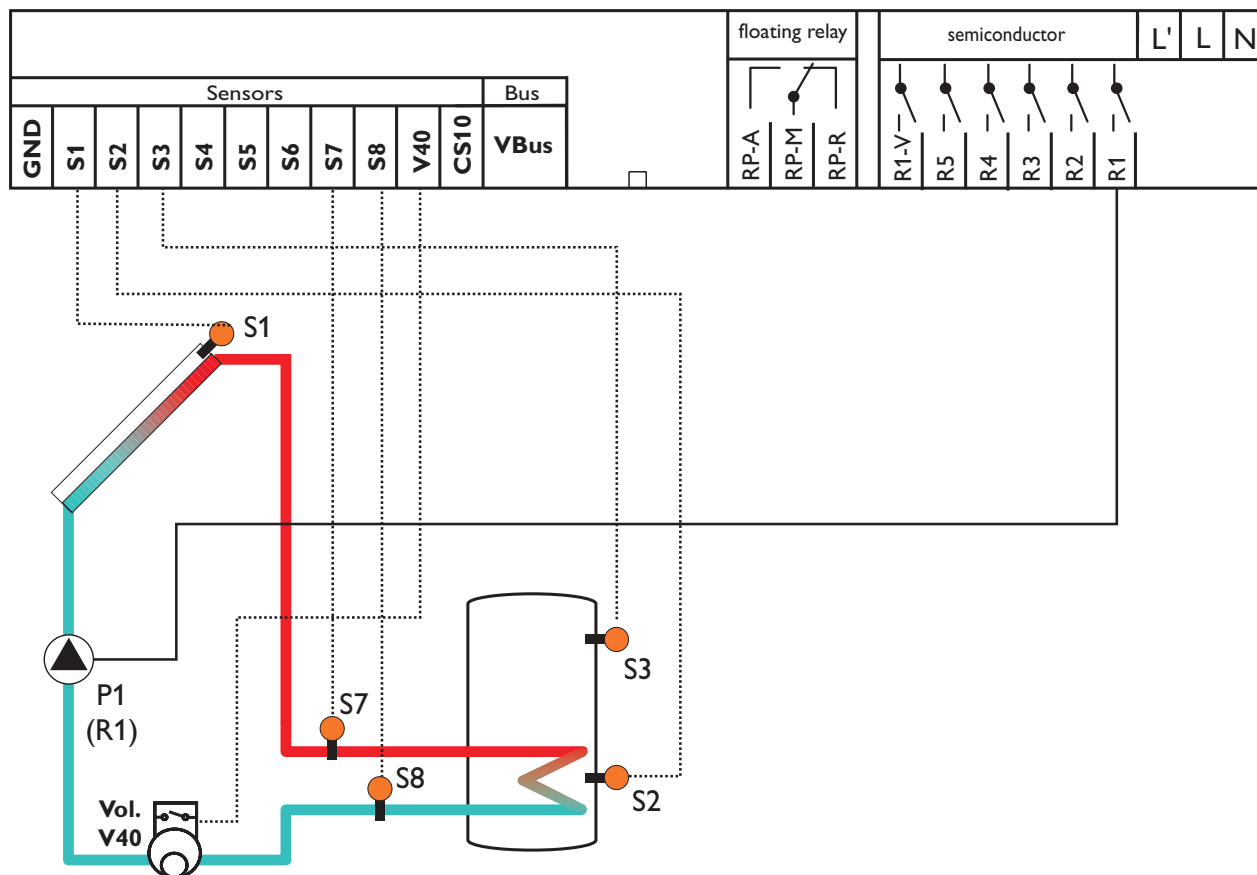

Relay output	Note
R1	solar pump (P1) with speed control
R2	
R3	
R4	
R5	
RP-R	
RP-M	
RP-A	

Sensor input	description
S1	temperature collector
S2	temperature store base
S3	temperature store top (sensor)
S7	flow temperature
S8	temperature return temperature sensor
V40	Flowmeter V40
CS10 (optional)	irradiation

channel	description	factory setting	change to	note
COL	temperature collector	-----		
TSTL	temperature store 1 base	-----		
TSTU	temperature store 1 top	-----		
TFL	flow temperature	-----		Is displayed after the heat quantity measurement option has been activated.
TRF	temperature return temperature sensor	-----		Is displayed after the heat quantity measurement option has been activated.
IRR	irradiation	-----		
n %	speed relay	-----		
h P	operating hours solar pump	-----		
FLOW	flow rate	-----		Is displayed after the heat quantity measurement option has been activated.
kWh	heat quantity kWh	-----		Is displayed after the heat quantity measurement option has been activated.
MWh	heat quantity MWh	-----		Is displayed after the heat quantity measurement option has been activated.
TIME	time	-----		Adjust the actual clock time.
Arr	arrangement choice	1		Arrangement 1: 1-store system
DT O	switch-on temperature difference	6.0 K		Adjust the desired switch-on temperature difference
DT F	switch-off temperature difference	4.0 K		Adjust the desired switch-off temperature difference
DT S	set temperature difference	10.0 K		Adjust the desired set temperature difference
RIS	rise	2 K		If the adjusted temperature difference DTS is reached and if the temperature increases by the difference RIS, the speed will be increased by 10% respectively.
S MX	maximum store temperature	60 °C		Adjust the desired maximum store temperature
EM	collector emergency temperature	140 °C		Adjust this value to 200°C when the collector emergency shutdown function should not start.
OCX	Option collector cooling	OFF		
OCN	Option minimum limitation	OFF		
OCF	Option frost protection	OFF		
OREC	option recooling	OFF		
OTC	option tube collector	OFF		
OHQM	option heat quantity measurement	OFF	On	Activate the heat quantity measurement option
FIMP	pulse rate - flow meter	1		Adjust the pulse rate of the flowmeter: V40/0,6 = 1l/Imp V40/1,5 = 10l/Imp V40/2,5 – V40/6,0 = 25l/Imp
MEDT	antifreeze type	1		Set antifreeze type 0: water 1: propylene glycol 2: ethylene glycol 3: Tyfocor® LS / G-LS
MED%	antifreeze concentration	45		Adjust the antifreeze concentration in Vol-%. If antifreeze type 0 or 3 is used, this channel will be 'hidden'.

channel	description	factory setting	change to	note
<b>CS 10</b>	solar irradiation sensor	<b>5</b>		
<b>n MN</b>	minimum speed relay 1	<b>30</b>		
<b>HND1</b>	manual operation relay 1	<b>AUTO</b>		
<b>HND2</b>	manual operation relay 2	<b>AUTO</b>		
<b>HND3</b>	manual operation relay 3	<b>AUTO</b>		
<b>HND4</b>	manual operation relay 4	<b>AUTO</b>		
<b>HND5</b>	manual operation relay 5	<b>AUTO</b>		
<b>HND6</b>	manual operation relay 6	<b>AUTO</b>		
<b>LANG</b>	language	<b>dE</b>		<b>dE = German En = English It = Italian Fr = French</b>
<b>PROG</b>	program number	<b>xx.xx</b>		
<b>VERS</b>	version number	<b>x.xx</b>		

**Distributed by:**



**Note**

The design and the specifications can be changed without notice.  
The illustrations may differ from the original product.