

# PSW Premium Set



## Mounting Electrical connection Adjustment



11205572

Thank you for buying this RESOL product.  
Please read this manual carefully to get the best performance from this unit.  
Please keep this manual safe.

en

Manual

[www.resol.com](http://www.resol.com)

## Safety advice

Please pay attention to the following safety advice in order to avoid danger and damage to people and property.

Danger of electric shock:

- When carrying out works, the device must first of all be disconnected from the mains.
- It must be possible to disconnect the device from the mains at any time.
- Do not use the device if it is visibly damaged.

The device must not be used by children or persons with reduced physical, sensory or mental abilities or without any experience and knowledge. Make sure that children do not play with the device!

Make sure that the housing is properly closed before commissioning the device.

## Target group

These instructions are exclusively addressed to authorised skilled personnel.

Only qualified electricians are allowed to carry out electrical works.

Initial commissioning must be effected by authorised skilled personnel.

Authorised skilled personnel are persons who have theoretical knowledge and experience with the installation, commissioning, operation, maintenance, etc. of electric/electronic devices and hydraulic systems and who have knowledge of relevant standards and directives.

## Instructions

Attention must be paid to the valid local standards, regulations and directives!

**Subject to technical change. Errors excepted.**

## Information about the product

### Proper usage

The device is designed for use in standard solar thermal systems and heating systems in compliance with the technical data specified in this manual.

Any use beyond this is considered improper.

Proper usage also includes compliance with the specifications given in this manual.

Improper use excludes all liability claims.



### Note

Strong electromagnetic fields can impair the function of the device.

- ➔ Make sure the device as well as the system are not exposed to strong electromagnetic fields.

### EU Declaration of conformity

The product complies with the relevant directives and is therefore labelled with the CE mark. The Declaration of Conformity is available upon request, please contact the manufacturer.



### Scope of delivery

The scope of delivery of this product is indicated on the packaging label.

### Storage and transport

Store the product at an ambient temperature of -20 ... +60 °C and in dry interior rooms only.

Transport the product in its original packaging only.

### Cleaning

Clean the product with a dry cloth. Do not use aggressive cleaning fluids.

### Decommissioning

1. Disconnect the device from the power supply.
2. Dismount the device.

## Disposal

---

- Dispose of the packaging in an environmentally sound manner.
- At the end of its working life, the product must not be disposed of as urban waste. Old appliances must be disposed of by an authorised body in an environmentally sound manner. Upon request we will take back your old appliances bought from us and guarantee an environmentally sound disposal of the devices.



## Description of symbols

**Warnings are indicated with a warning symbol!**

**Signal words** describe the danger that may occur, when it is not avoided.

**WARNING** means that injury, possibly life-threatening injury, can occur.



→ It is indicated how to avoid the danger described.

**ATTENTION** means that damage to the appliance can occur.



→ It is indicated how to avoid the danger described.



**Note**

Notes are indicated with an information symbol.

- Texts marked with an arrow indicate one single instruction step to be carried out.
- 1. Texts marked with numbers indicate several successive instruction steps to be carried out.

## Contents

### PSW Premium

1	Overview .....	5
2	Installation .....	6
2.1	Mounting.....	6
2.2	Electrical connection.....	6
2.3	Inversion of the output signal .....	7
2.4	Overrun function.....	7
2.5	Application example.....	8
2.6	LED flashing codes .....	8
3	Tips for fault diagnostics .....	8
4	Accessories .....	8

### Wilo PARA

1	General .....	9
2	Safety .....	9
2.1	Indication of instructions in the operating manual .....	9
2.2	Personnel qualifications.....	10
2.3	Danger in the event of non-observance of the safety instructions.....	10
2.4	Safety consciousness on the job.....	10
2.5	Safety instructions for the operator.....	10
2.6	Safety instructions for installation and maintenance work .....	11
2.7	Unauthorised modification and manufacture of spare parts .....	11
2.8	Improper use .....	11
3	Transport and interim storage.....	12
4	Intended use .....	12
5	Product Information.....	12
5.1	Technical data .....	12
6	Description and function .....	13
6.1	Description of the pump.....	13
6.2	Functions .....	13
7	Installation and electrical connection.....	13
7.1	Installation .....	13
7.2	Electrical connection.....	14
8	Commissioning.....	14
9	Maintenance .....	14
10	Faults, Causes and Remedies.....	15
11	Disposal.....	15

# PSW Premium

## 1 Overview

The PSW Premium Pump signal converter is used for connecting speed-controlled high-efficiency pumps with a PWM or 0-10V control input to a controller without a corresponding output. Thus, when replacing the pump, speed control can be enabled without replacing the controller.

The PSW Premium pump signal converter converts the 230 V signal of the controller to which a standard pump had previously been connected, into a signal that enables speed control of a HE pump.

The PSW Premium is equipped with a relay output for the power supply of the pump. Moreover, it has an overrun function to reduce the number of switching processes for high-efficiency pumps.

- **For solar and heating pumps**
- **PWM or 0-10 V output signal**
- **Inversion of the output signal possible**
- **Integrated power supply of the pump**
- **Overrun**
- **Pump status indication**

1 HE pump per signal converter connectable.

The following signal conversions are possible:

Output signal \ Input signal	PWM	PWM inv.	0-10V	0-10V inv.
On / Off	x	x	x	x
Burst / wave packet	x	x	x	x
Leading-edge phase control	x	x	x	x
Trailing-edge phase control	x	x	x	x

Not suitable for heat pumps and DHW exchange controllers

## Technical data

**Inputs:** On/Off, bursts / wave packets, phase cutting

**Outputs:** 1 semiconductor relay, 1 PWM, 1 0-10 V

**PWM frequency:** 625 Hz  $\pm$ 2,5 %

**PWM voltage:** 11 V

**Switching capacity:** 1A / 230 V~ (semiconductor relay)

**Power supply:** 230 V~ (50 Hz)

**Supply connection:** type X attachment

**Power consumption:** max. 1.7 VA

**Mode of operation:** type 1.Y

**Rated impulse voltage:** 2.5 kV~

**Functions:** signal converter, converting a speed-controlled 230 V signal into a PWM or 0-10 V signal.

**Housing:** plastic, PC-ABS and PMMA

**Indication / Display:** operating control LED

**Mounting:** wall mounting

**Protection type:** IP 20 / EN 60529

**Protection class:** I

**Ambient temperature:** 0 ... 40 °C

**Degree of pollution:** 2

**Humidity:** 10 ... 90 %

**Overvoltage category:** 2

**Fuse:** T1A

**Maximum altitude:** 2000 m above MSL

**Dimensions:**  $\varnothing$  130 mm, depth 45 mm

**Dimensions and minimum distances**

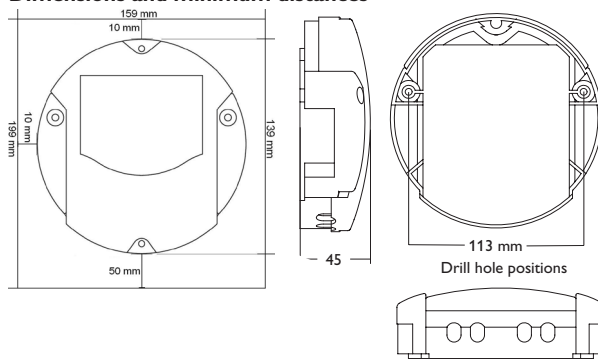

## 2 Installation

### 2.1 Mounting

#### **WARNING! Electric shock!**



Upon opening the housing, live parts are exposed!

→ Always disconnect the controller from power supply before opening the housing!

The unit must only be located in dry interior rooms.

If the device is not equipped with a mains connection cable and a plug, the device must additionally be supplied from a double pole switch with contact gap of at least 3 mm.

Please pay attention to separate routing of sensor cables and mains cables.

In order to mount the device to the wall, carry out the following steps:

1. Choose a mounting location.
2. Drill 2 holes (Ø 6 mm, centres 113 mm) and insert the wall plugs.
3. Fasten the base part of the housing by means of the enclosed screws (4x40mm, (1)).

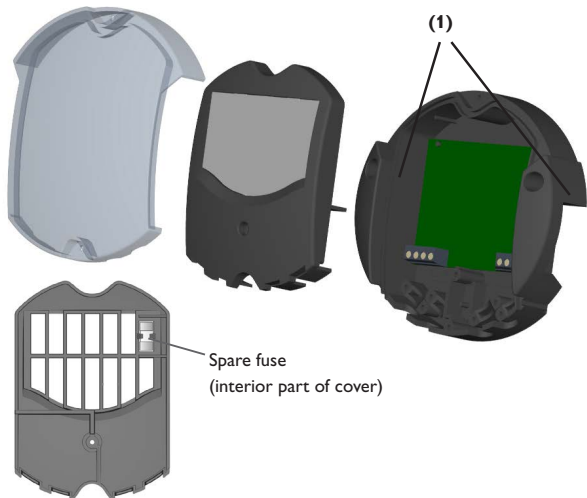

Spare fuse  
(interior part of cover)

### 2.2 Electrical connection

#### **WARNING! Electric shock!**



Upon opening the housing, live parts are exposed!

→ Always disconnect the controller from power supply before opening the housing!

#### **ATTENTION! ESD damage!**



Electrostatic discharge can lead to damage to electronic components!

→ **Take care to discharge properly before touching the inside of the device! To do so, touch a grounded surface such as a radiator or tap!**



#### **Note:**

Strong electromagnetic fields can impair the function of the device.

→ Make sure the device as well as the system are not exposed to strong electromagnetic fields.



#### **Note:**

It must be possible to disconnect the device from the mains at any time.

→ Install the mains plug so that it is accessible at any time.

→ If this is not possible, install a switch that can be accessed.

If the mains cable is damaged, it must be replaced by a special connection cable which is available from the manufacturer or its customer service.

#### **Do not use the device if it is visibly damaged!**

Connecting the device to the power supply must always be the last step of the installation!

Depending on the product version, mains cables and signal cables are already connected to the device. If that is not the case, please proceed as follows:

Attach flexible cables to the housing with the enclosed strain relief and the corresponding screws.

The device is supplied with power via a mains cable. The mains voltage must be 230 V~ (50 Hz).

Connect the signal cable from the controller to the low voltage input of the device:

**R In (1/2)** = double-pole 230-V-control signal cable from the controller

**ATTENTION! Malfunction!**

Pumps with line break detection run with minimum speed if the control signal is 0V.

→ **Do not operate pumps with line break detection by a 0-10V signal!**

Connect the blue wire of the signal cable of the pump to **┘ (4)**. Depending on the signal type, connect the brown wire to one of the following terminals:

**10V (3)** = 0-10V control signal for the HE pump

**PWM (5)** = PWM control signal for the HE pump

The mains connection of the device is at the following terminals:

**N (8)** = neutral conductor N (blue)

**L (9)** = conductor L (brown or black)

Ground conductor  $\div$  (common terminal block) = PE conductor (yellow/green)

Power supply for the pump, connect the cable to the **R Out** relay output:

**N (6)** = neutral conductor N pump (blue)

**R Out (7)** = 230V power supply of the pump via the relay output (brown)

Ground conductor  $\div$  (common terminal block) = PE conductor (yellow/green)

The power supply of the pump can also take place directly via the 230 V mains voltage.

**2.3 Inversion of the output signal**

By means of the lower two-pole jumper on the left-hand side above the output terminals, the output signal can be issued inverted or not inverted.

Jumper open: not inverted (solar pump)

Jumper connected: inverted (heating pump)

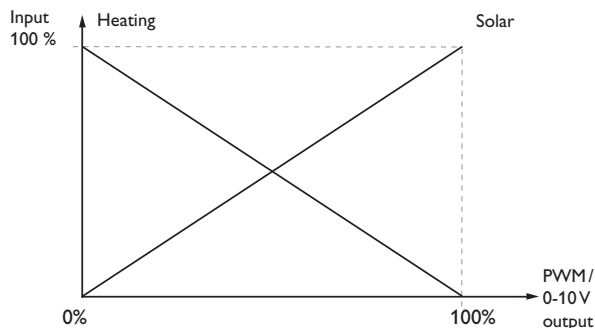
**2.4 Overrun function**

By means of the upper two-pole jumper the overrun function can be activated or deactivated.

The overrun function can be used to reduce the number of switching processes for high-efficiency pump. Power supply for the pump will remain switched on for another 30 minutes after the input signal has signalled a switch-off.

Jumper open: Overrun function on



Overrun Off
PWM 2

Jumper connected: Overrun function off



Overrun Off
PWM 2

**ATTENTION! System damage!**

If a solar pump is used, connecting the lower jumper (PWM 2) can lead to system damage!

→ **Do not connect the lower jumper (PWM 2).**

## 2.5 Application example

Example: connection to a DeltaSol® BS controller

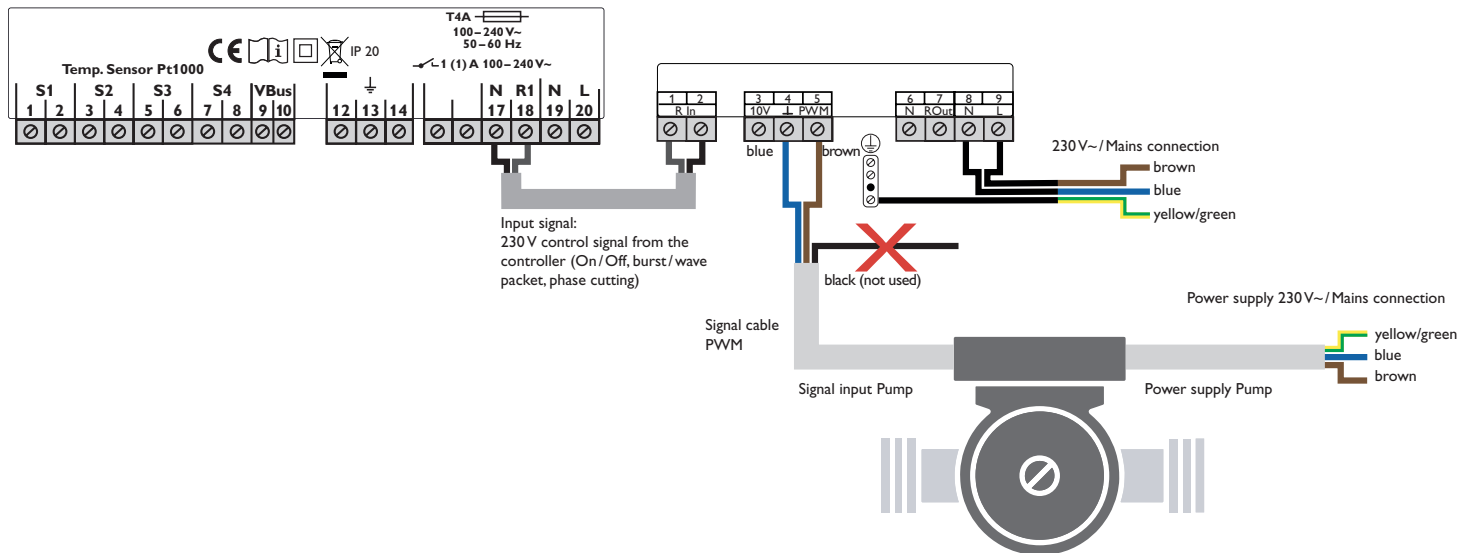

## 2.6 LED flashing codes

Flashing code	Description
Green:	Output on standby
Green flashing:	Output active

## 3 Tips for fault diagnostics

If the device does not work perfectly, please check the following items:

If the device does not switch on when the power supply is connected, please check the fuse. The device is protected by a T1A fuse, which can be replaced after having removed the housing and the cover. A spare fuse is enclosed on the backside of the cover.

## 4 Accessories



### HE-Check – Testing device for PWM- and 0-10V signals

With the HE-Check, the function of the pump and the signals of the controller can be checked quickly and easily.



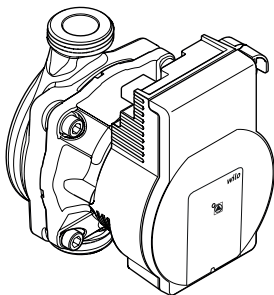

## 1 General

### About this document

The language of the original operating instructions is English. All other languages of these instructions are translations of the original operating instructions.

These installation and operating instructions are an integral part of the product.

They must be kept readily available at the place where the product is installed.

Strict adherence to these instructions is a precondition for the proper use and correct operation of the product.

The installation and operating instructions correspond to the relevant version of the product and the underlying safety regulations and standards valid at the time of going to print.

### EC declaration of conformity:

A copy of the EC declaration of conformity is a component of these operating instructions.

If a technical modification is made on the designs named there without our agreement or the declarations made in the installation and operating instructions on product/personnel safety are not observed, this declaration loses its validity.

## 2 Safety

These operating instructions contain basic information which must be adhered to during installation, operation and maintenance. For this reason, these operating instructions must, without fail, be read by the service technician and the responsible specialist/operator before installation and operation.

It is not only the general safety instructions listed under the main point “safety” that must be adhered to but also the special safety instructions with danger symbols included under the following main points.

### 2.1 Indication of instructions in the operating manual

#### Symbols:



**General danger symbol**



**Danger due to electrical voltage**



**NOTE:**

### Signal words:

#### **DANGER!**

Acutely dangerous situation.

Non-observance results in death or the most serious of injuries.

#### **WARNING!**

The user can suffer (serious) injuries. ‚Warning‘ implies that (serious) injury to persons is probable if this information is disregarded.

#### **CAUTION!**

There is a risk of damaging the product/unit. ‚Caution‘ implies that damage to the product is possible if this information is disregarded.

#### **NOTE:**

Useful information on handling the product. It draws attention to possible problems.

Information applied directly to the product, such as:

- Direction of rotation arrow,
- Identifiers for connections,
- Name plate,
- warning sticker, must be strictly compliant with and kept in a fully legible condition.

### 2.2 Personnel qualifications

---

The installation, operating and maintenance personnel must have the appropriate qualifications for this work. Area of responsibility, terms of reference and monitoring of the personnel have to be ensured by the operator. If the personnel are not in possession of the necessary knowledge, they have to be trained and instructed. This can be accomplished if necessary by the manufacturer of the product at the request of the operator.

### 2.3 Danger in the event of non-observance of the safety instructions

---

Non-observance of the safety instructions can result in risk of injury to persons and damage to the environment and the product/unit. Non-observance of the safety instructions results in the loss of any claims to damages.

In detail, non-observance can, for example, result in the following risks:

- Danger to persons from electrical, mechanical and bacteriological influences,
- Damage to the environment due to leakage of hazardous materials,
- Property damage,
- Failure of important product/unit functions,
- Failure of required maintenance and repair procedures.

### 2.4 Safety consciousness on the job

---

The safety instructions included in this installation and operating instructions, the existing national regulations for accident prevention together with any internal working, operating and safety regulations of the operator are to be compliant with.

### 2.5 Safety instructions for the operator

---

This appliance is not intended for use by persons (including children) with reduced physical, sensory or mental capabilities, or lack of experience and knowledge, unless they have been given supervision or instruction concerning use of the appliance by a person responsible for their safety.

Children should be supervised to ensure that they do not play with the appliance.

- If hot or cold components on the product/the unit lead to hazards, local measures must be taken to guard them against touching.
- Guards protecting against touching moving components (such as the coupling) must not be removed whilst the product is in operation.
- Leakages (e.g. from a shaft seal) of hazardous fluids (e.g. explosive, toxic or hot) must be led away so that no danger to persons or to the environment arises. National statutory provisions are to be complied with.
- Danger from electrical current must be eliminated. Local directives or general directives [e.g. IEC, VDE etc.] and local energy supply companies must be adhered to.
- Faults of electronic devices due to electromagnetic fields. Electromagnetic fields are created during the operation of pumps with frequency converter. Interference of electronic devices may be the result. The result may be a device malfunction, which can result in damage to the health or even death, e.g. of persons carrying implanted active or passive medical devices. Therefore, during operation the presence of any persons e.g. with cardiac pacemakers in the vicinity of the unit/pump should be prohibited. With magnetic or electronic data media, the loss of data is possible.



### **WARNING! Danger due to strong magnetic field!**

**Inside the machine there is always a strong magnetic field that can cause injury and damage to property in the event of incorrect dismantling.**

- It is only permitted to have the rotor removed from the motor housing by qualified personnel!
- There is a crushing hazard! When pulling the rotor out of the motor, it may be suddenly pulled back into its initial position by the strong magnetic field.
- If the unit consisting of impeller, bearing shield and rotor is pulled out of the motor, persons with medical aids, such as cardiac pacemakers, insulin pumps, hearing aids, implants or similar are at risk. Death, severe injury and damage to property may be the result. For such persons, a professional medical assessment is always necessary.
- Electronic devices may be impaired functionally or damaged by the strong magnetic field of the rotor.
- If the rotor is outside the motor, magnetic objects may be attracted very suddenly. That can result in injury and damage to property.

In assembled condition, the rotor's magnetic field is guided in the motor's iron core. There is therefore no harmful magnetic field outside the machine.

### 2.6 Safety instructions for installation and maintenance work

The operator must ensure that all installation and maintenance work is carried out by authorized and qualified personnel, who are sufficiently informed from their own detailed study of the operating instructions.

Work to the product/unit must only be carried out when at a standstill. It is mandatory that the procedure described in the installation and operating instructions for shutting down the product/unit be complied with.

Immediately on conclusion of the work, all safety and protective devices must be put back in position and/or re-commissioned.

### 2.7 Unauthorised modification and manufacture of spare parts

Unauthorised modification and manufacture of spare parts will impair the safety of the product/personnel and will make void the manufacturer's declarations regarding safety.

Modifications to the product are only permissible after consultation with the manufacturer. Original spare parts and accessories authorised by the manufacturer ensure safety. The use of other parts will absolve us of liability for consequential events.

### 2.8 Improper use

The operating safety of the supplied product is only guaranteed for conventional use in accordance with Section 7 of the operating instructions. The limit values must on no account fall under or exceed those specified in the catalogue/data sheet.

### 3 Transport and interim storage

Immediately after receiving check the product for damage in transit.



#### **CAUTION! Risk of damage to property!**

Incorrect transport and interim storage can cause damage to the product.

The pump must be protected from moisture, frost and mechanical damage due to impact during transport and interim storage.

#### **Transport conditions**

The device must not be exposed to temperatures outside the range of -40 °C up to +85 °C. The transport conditions must be applied max. three months.

#### **Storage conditions**

The device must not be exposed to temperatures outside the range 0 °C up to +40 °C. The storage time can be up to two years. The remaining water, in case of customer production tests, cannot lead to frost damages.

### 4 Intended use

The circulation pumps of the Wilo-PARA series are designed for hotwater heating systems and other similar systems with constantly changing volume flows. Approved fluids are heating water in accordance with VDI 2035, water/glycol mixture at a mixing ratio of max. 1:1. If glycol is added, the delivery data of the pump must be corrected according to the higher viscosity, depending on the mixing ratio percentage.

Intended use also includes following these instructions.

Any other use is regarded as incorrect use.

### 5 Product Information

#### 5.1 Technical data

Approved fluids (other fluids on request)	Heating water (in accordance with VDI 2035) Water-glycol mixtures (max. 1:1; above 20% admixture, the pumping data must be checked)
<b>Power</b>	
Energy Efficiency Index (EEL)	≤ 0.20
Max. delivery head (Hmax)	7.7 m
Max. volume flow (Qmax)	3.5 m <sup>3</sup> /h
<b>Permitted field of application</b>	
Temperature range for applications in heating and air-conditioning systems at max. ambient temperature. See nameplate for "TF" indication	Ambient 58 °C = TF 0 to 100 °C of 62 °C = 0 to 90 °C of 66 °C = 0 to 80 °C of 71 °C = 0 to 70 °C
Max. operating pressure	According information on the nameplate
<b>Electrical connection</b>	
Mains connection	1~230 V +10%/-15%, 50/60 Hz (acc. IEC 60038)
<b>Motor/Electronics</b>	
Electromagnetic compatibility	EN 61800-3
Emitted interference	EN 61000-6-3 / EN 61000-6-4
Interference resistance	EN 61000-6-1 / EN 61000-6-2
Protection class	IPx4D
Insulation class	F
RoHS	conform
<b>Minimum suction head at suction port for avoiding cavitation at water pumping temperature</b>	
Minimum suction head at 50/95°C	0.5 / 4.5 m

## 6 Description and function

### 6.1 Description of the pump

The pump (Fig. 1) consists of a hydraulic system, a glandless pump motor with a permanent magnet rotor, and an electronic control module with an integrated frequency converter. The control module receives an external PWM signal for speed control. This version is equipped with an LED for displaying the operating status of the pump (see chap. 12, p. 15).

### 6.2 Functions

#### External control via a PWM signal

The actual/setpoint level assessment required for control is referred to a remote controller. The remote controller sends a PWM signal as an actuating variable to the Pump.

The PWM signal generator gives a periodic order of pulses to the pump (the duty cycle), according to DIN IEC 60469-1. The actuating variable is determined by the ratio between pulse duration and the pulse period. The duty cycle is defined as a ratio without dimension, with a value of 0 ... 1% or 0 ... 100%. See PWM signal logic 1 (heating) Fig. 2a and PWM signal logic 2 (solar) Fig. 2b.

## 7 Installation and electrical connection



### **DANGER! Danger of death!**

Incorrect installation and electrical connection can result in fatal injury.

- Installation and electrical connection may only be carried out by qualified personnel and in accordance with the applicable regulations!
- Adhere to regulations for accident prevention!

### 7.1 Installation

- Only install the pump after all welding and soldering work has been completed and, if necessary, the pipe system has been flushed through.
- Install the pump in a readily accessible place for easy inspection and dismantling.
- When installing in the feed of open systems, the safety supply must branch off upstream of the pump (DIN EN 12828).
- Install check valves upstream and downstream of the pump to facilitate a possible pump replacement.
  - Perform installation so that any leaking water cannot drip onto the control module,
  - To do this, align the upper gate valve laterally.
- In thermal insulation work, make sure that the pump motor and the module are not insulated. The condensate-drain openings must remain uncovered.
- Install the pump with the power switched off and the pump motor in a horizontal position see Fig. 3 for installation positions of the pump.
- Direction arrows on the pump housing indicate the direction of the flow.

## DANGER! Danger of death!

A fatal shock may occur if the electrical connection is not made correctly.

- Only allow the electrical connection to be made by an electrician approved by the local electricity supplier and in accordance with the local regulations in force.
- Disconnect the power supply before any work.
- The current type and voltage must correspond to the details on the name plate.
- Maximum back-up fuse: 10 A, slow bow.
- Earth the pump according to the regulations.
- Mains connection: L, N, PE

### Note:

For information on connecting the mains and signal cables see chap. 2.5, p. 8.

Fig. 1:

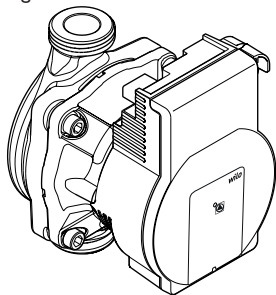

Fig. 2a:

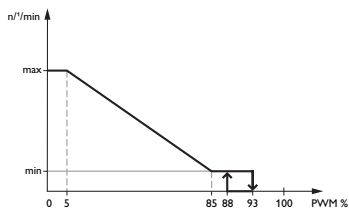

Fig. 2b:

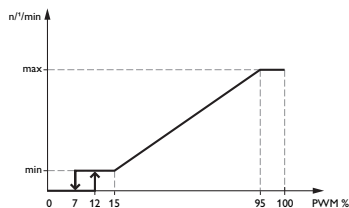
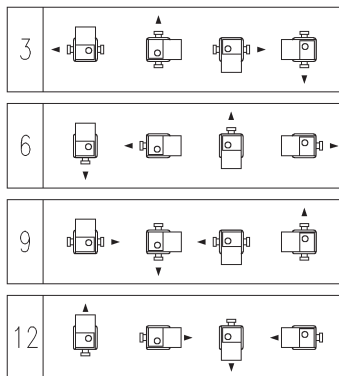

Fig. 3:



## 8 Commissioning

### WARNING! Risk of injury and damage to property!

Incorrect commissioning can lead to injuries to persons and damage to property.

- Commissioning by qualified personnel only!
  - Depending on the operating status of the pump or system (fluid temperature), the entire pump can become very hot.
- Touching the pump can cause burns!

## 9 Maintenance

### DANGER! Danger of death!

A fatal shock may occur when working on electrical equipment.

- The pump must be electrically isolated and secured against unauthorised switch-on during any maintenance or repair work.
- Any damage to the connecting cable must always be rectified by a qualified electrician only.

After successful maintenance and repair work, install and connect the pump according to the "Installation and electrical connection" chapter. Switch on the pump according to the "Commissioning" chapter.

## 10 Faults, Causes and Remedies

LED	Meaning	Diagnostic	Cause	Remedy
lights green	Pump in operation	Pump runs according its setting	Normal operation	
blinks quick green		Pump in standby	Normal operation	
blinks red/green	Pump in function but stopped	Pump restarts by itself after the fault is disappeared	1. Undervoltage $U < 160\text{ V}$ or Overvoltage $U > 253\text{ V}$ 2. Modul overheating: temperatur inside motor too high	1. Check voltage supply $195\text{ V} < U < 253\text{ V}$ 2. Check water and ambient temperature
blinks red	Pump out of function	Pump stopped (blocked)	Pump does not restart by itself due to a permanent failure	Change pump
LED off	No power supply	No voltage on electronics	1. Pump is not connected to power supply 2. LED is damaged 3. Electronics are damaged	1. Check cable connection 2. Check if pump is running 3. Change pump

**If the fault cannot be remedied, please consult the specialist technician or the Wilo factory after-sales service.**

## 11 Disposal

Damage to the environment and risks to personal health are avoided by the proper disposal and appropriate recycling of this product.

1. Use public or private disposal organisations when disposing of all or part of the product.
2. For more information on proper disposal, please contact your local council or waste disposal office or the supplier from whom you obtained the product.

**Technical information subject to change without prior notice!**

Distributed by:

## **RESOL – Elektronische Regelungen GmbH**

Heiskampstraße 10  
45527 Hattingen / Germany

Tel.: +49 (0) 23 24 / 96 48 - 0

Fax: +49 (0) 23 24 / 96 48 - 755

[www.resol.com](http://www.resol.com)

[info@resol.com](mailto:info@resol.com)

### **Important note**

The texts and drawings in this manual are correct to the best of our knowledge. As faults can never be excluded, please note:

Your own calculations and plans, under consideration of the current standards and directions should only be basis for your projects. We do not offer a guarantee for the completeness of the drawings and texts of this manual - they only represent some examples. They can only be used at your own risk. No liability is assumed for incorrect, incomplete or false information and / or the resulting damages.

### **Note**

The design and the specifications can be changed without notice.

The illustrations may differ from the original product.

### **Imprint**

This mounting and operation manual including all parts is copyrighted. Any other use outside the copyright requires the approval of RESOL – Elektronische Regelungen GmbH. This especially applies to copies, translations, micro films and the storage into electronic systems.

© RESOL – Elektronische Regelungen GmbH