

# DeltaTherm® HC

**RESOL®**

beginning with version 1.10

## Heating controller

Manual for the  
specialised craftsman

Installation

Operation

Functions and options

Troubleshooting



11210353



Adjust your heating via app

Thank you for buying this RESOL product.  
Please read this manual carefully to get the best performance from this unit.  
Please keep this manual safe.

en

Manual

[www.resol.com](http://www.resol.com)

## Safety advice

Please pay attention to the following safety advice in order to avoid danger and damage to people and property.

Danger of electric shock:

- When carrying out works, the device must first of all be disconnected from the mains.
- It must be possible to disconnect the device from the mains at any time.
- Do not use the device if it is visibly damaged!

The device must not be used by children or persons with reduced physical, sensory or mental abilities or without any experience and knowledge. Make sure that children do not play with the device!

Only connect accessories authorised by the manufacturer to the device.

Make sure that the housing is properly closed before commissioning the device.

Set the code to the customer code before handing over the controller to the customer.

## Target group

These instructions are exclusively addressed to authorised skilled personnel.

Only qualified electricians are allowed to carry out electrical works.

Initial commissioning must be effected by authorised skilled personnel.

Authorised skilled personnel are persons who have theoretical knowledge and experience with the installation, commissioning, operation, maintenance, etc. of electric/electronic devices and hydraulic systems and who have knowledge of relevant standards and directives.

## Instructions

Attention must be paid to the valid local standards, regulations and directives!

**Subject to technical change. Errors excepted.**

## Information about the product

### Proper usage

The controller is designed for use in heating systems in compliance with the technical data specified in this manual.

Any use beyond this is considered improper.

Proper usage also includes compliance with the specifications given in this manual. Improper use excludes all liability claims.



### Note

Strong electromagnetic fields can impair the function of the controller.

- ➔ Make sure the controller as well as the system are not exposed to strong electromagnetic fields.

### EU Declaration of conformity

The product complies with the relevant directives and is therefore labelled with the CE mark. The Declaration of Conformity is available upon request, please contact the manufacturer.



### Scope of delivery

The scope of delivery of this product is indicated on the packaging label.

### Storage and transport

Store the product at an ambient temperature of 0 ... 40 °C and in dry interior rooms only.

Transport the product in its original packaging only.

### Cleaning

Clean the product with a dry cloth. Do not use aggressive cleaning fluids.

### Decommissioning

1. Disconnect the device from the power supply.
2. Dismount the device.

## Disposal

- Dispose of the packaging in an environmentally sound manner.
- At the end of its working life, the product must not be disposed of as urban waste. Old appliances must be disposed of by an authorised body in an environmentally sound manner. Upon request we will take back your old appliances bought from us and guarantee an environmentally sound disposal of the devices.



## Description of symbols

### Warnings are indicated with a warning symbol!

**Signal words** describe the danger that may occur, when it is not avoided.

**WARNING** means that injury, possibly life-threatening injury, can occur.



→ It is indicated how to avoid the danger described.

**ATTENTION** means that damage to the appliance can occur.



→ It is indicated how to avoid the danger described.



### Note

Notes are indicated with an information symbol.

- Texts marked with an arrow indicate one single instruction step to be carried out.
- 1. Texts marked with numbers indicate several successive instruction steps to be carried out.

## DeltaTherm® HC Heating controller

The heating controller can control a weather-compensated heating circuit, the DHW loading and the backup heating demand for both.

With up to five extension modules, further heating circuits, additional DHW functions such as circulation or thermal disinfection, and the efficient implementation of further heat sources can be controlled.

### Contents

<b>1</b>	<b>Overview</b> .....	<b>5</b>
<b>2</b>	<b>Installation</b> .....	<b>6</b>
2.1	Mounting .....	6
2.2	Electrical connection .....	6
2.3	Data communication / Bus .....	8
2.4	SD card slot.....	8
<b>3</b>	<b>Operation and function</b> .....	<b>8</b>
3.1	Buttons .....	8
3.2	Selecting menu points and adjusting values .....	9
<b>4</b>	<b>Commissioning</b> .....	<b>14</b>
4.1	Schemes with basic settings.....	16
4.2	ErP temperature controls classes.....	16
4.3	Step-by-step parameterisation .....	26
<b>5</b>	<b>Functions and options</b> .....	<b>27</b>
5.1	Menu structure .....	27
5.2	Status menu .....	28
5.3	Heating.....	28
5.4	Arrangement .....	28
5.5	HQM .....	29
5.6	Meas./ Balance values .....	29
5.7	Messages.....	29
<b>6</b>	<b>Heating</b> .....	<b>30</b>
6.1	Shared relays.....	30
6.2	Heating circuits .....	33
6.3	Optional functions .....	41
<b>7</b>	<b>Arrangement</b> .....	<b>46</b>
7.1	Optional functions .....	46
<b>8</b>	<b>HQM</b> .....	<b>55</b>
<b>9</b>	<b>Basic settings</b> .....	<b>56</b>
<b>10</b>	<b>SD card</b> .....	<b>57</b>
<b>11</b>	<b>Manual mode</b> .....	<b>58</b>

Due to the flexible application and extension possibilities, the heating controller is also ideal for larger objects such as apartment houses, residential homes and industrial buildings.

<b>12</b>	<b>User code</b> .....	<b>58</b>
<b>13</b>	<b>In-/Outputs</b> .....	<b>59</b>
13.1	Modules .....	59
13.2	Inputs.....	59
13.3	Outputs .....	60
<b>14</b>	<b>Troubleshooting</b> .....	<b>62</b>
<b>15</b>	<b>Accessories</b> .....	<b>64</b>
15.1	Sensors and measuring instruments .....	65
15.2	VBus® accessories .....	65
15.3	Interface adapters.....	65
<b>16</b>	<b>Index</b> .....	<b>66</b>

### Navigator

#### Installation page 6

For mounting and connecting the controller, see page 6.

#### Commissioning page 14

For commissioning the controller, see page 14.

#### Settings page 26

For making adjustments in the main and additional functions (including chimney sweeper and screed drying), see page 26.

#### Data communication page 57

For establishing communication to the controller, see page 57.

#### Troubleshooting page 62

When an error has occurred, see page 62 for diagnostics and troubleshooting.

## 1 Overview

- 9 pre-configured basic systems and pre-programmed optional functions
- 30 pre-programmed schemes for the temperature controls classes II, III, V, VI, VII and VIII
- Up to 5 extension modules via VBus® connectable (39 sensors and 30 relays in total), up to 6 weather-compensated heating circuits
- 2 inputs for digital Grundfos Direct Sensors™
- Screed drying function
- Data logging, storing and firmware updates via SD memory card
- Modulating heating control with 0-10 V boiler control
- Weather-compensated control with room influence or demand-based room control with up to 5 room temperature sensors
- Remote access with a room control unit or the VBus®Touch HC App

### Dimensions and minimum distances

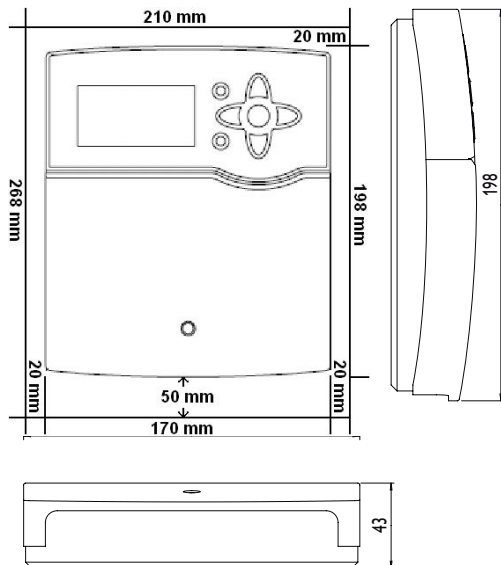

### Technical data

**Inputs:** 8 (9) inputs for Pt500, Pt1000, or KTY temperature sensors, 1 V40 impulse input, inputs for 2 digital Grundfos Direct Sensors™, 1 input for a CS10 irradiation sensor

**Outputs:** 4 semiconductor relays, 1 potential-free relay, 2 PWM outputs

**PWM frequency:** 1000 Hz

**PWM voltage:** 10.5 V

**Switching capacity:**

1 (1) A 240 V~ (semiconductor relay)

4 (1) A 240 V== (potential-free relay)

4 (1) A 24 V == (potential-free relay)

**Total switching capacity:** 4 A 240 V~

**Power supply:** 100–240 V~ (50–60 Hz)

**Supply connection:** type Y attachment

**Standby:** 0.94 W

**Temperature controls class:** VIII

**Energy efficiency contribution:** 5 %

**Mode of operation:** type 1.B.C.Y action

**Rated impulse voltage:** 2.5 kV

**Data interface:** VBus®, SD card slot

**VBus® current supply:** 60 mA

**Functions:** screed drying, weather-compensated heating circuit control, backup heating, DHW heating with priority logic, circulation, thermal disinfection, heat quantity measurement, optional functions such as solid fuel boiler, return preheating, etc.

**Housing:** plastic, PC-ABS and PMMA

**Mounting:** wall mounting, also suitable for mounting into patch panels

**Indication / Display:** full graphic display, operating control LED (directional pad) and background illumination

**Operation:** 7 buttons at the front of the housing

**Protection type:** IP 20 / DIN EN 60529

**Protection class:** I

**Ambient temperature:** 0 ... 50 °C

**Degree of pollution:** 2

**Fuse:** T4A

**Overvoltage category:** 2

**Maximum altitude:** 2000 m above MSL

**Dimensions:** 198 x 170 x 43 mm

## 2 Installation

### 2.1 Mounting

#### **WARNING!** Electric shock!



Upon opening the housing, live parts are exposed!

→ **Always disconnect the device from power supply before opening the housing!**



#### **Note**

Strong electromagnetic fields can impair the function of the device.

→ Make sure the device as well as the system are not exposed to strong electromagnetic fields.

The unit must only be located in dry interior rooms.

If the device is not equipped with a mains connection cable and a plug, the device must additionally be supplied from a double pole switch with contact gap of at least 3 mm.

Please pay attention to separate routing of sensor cables and mains cables.

In order to mount the device to the wall, carry out the following steps:

1. Unscrew the cross-head screw from the cover and remove it along with the cover from the housing.
2. Mark the upper fastening point on the wall. Drill and fasten the enclosed wall plug and screw leaving the head protruding.
3. Hang the housing from the upper fastening point and mark the lower fastening points (centres 150 mm).
4. Insert lower wall plugs.
5. Fasten the housing to the wall with the lower fastening screw and tighten.
6. Carry out the electrical wiring in accordance with the terminal allocation (see page 7).
7. Put the cover on the housing.
8. Attach with the fastening screw.

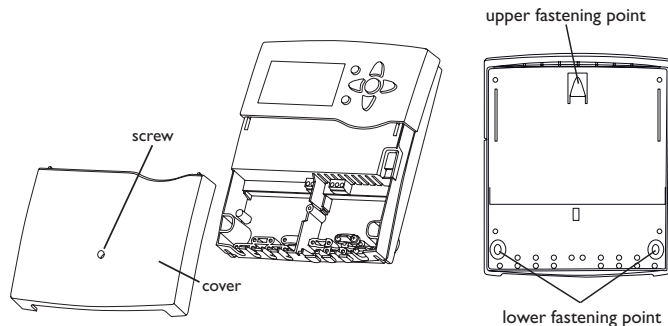

### 2.2 Electrical connection

#### **WARNING!** Electric shock!



Upon opening the housing, live parts are exposed!

→ **Always disconnect the device from power supply before opening the housing!**

#### **ATTENTION!** ESD damage!



Electrostatic discharge can lead to damage to electronic components!

→ **Take care to discharge properly before touching the inside of the device! To do so, touch a grounded surface such as a radiator or tap!**



#### **Note**

Connecting the device to the power supply must always be the last step of the installation!



#### **Note:**

The pump speed must be set to 100% when auxiliary relays or valves are connected.



#### **Note:**

It must be possible to disconnect the device from the mains at any time.

→ Install the mains plug such that it is accessible at any time.

→ If this is not possible, install a switch that can be accessed.

If the mains cable is damaged, it must be replaced by a special connection cable which is available from the manufacturer or its customer service.

## Do not use the device if it is visibly damaged!

Depending on the product version, cables are already connected to the device. If that is not the case, please proceed as follows:

Attach flexible cables to the housing with the enclosed strain relief and the corresponding screws.

The controller is equipped with 5 relays in total to which loads such as pumps, valves, etc. can be connected:

Relays 1 ... 4 are semiconductor relays, designed for pump speed control.

Conductor R1 ... R4

Neutral conductor N (common terminal block)

Protective earth conductor  $\oplus$  (common terminal block)

Relay 5 is a potential-free relay:

Connections to the R5 terminals can be made with either polarity.

The **temperature sensors** (S1 to S8) have to be connected to the terminals S1 ... S8 and GND (either polarity).

The cables carry low voltage and must not run together in a cable conduit with cables carrying a voltage higher than 50 V (please pay attention to the valid local regulations). The cable lengths depend on the cross sectional area.

Example: up to 100 m at 1.5 mm<sup>2</sup>, up to 50 m at 0.75 mm<sup>2</sup>. The cables can be extended with a two-wire cable.

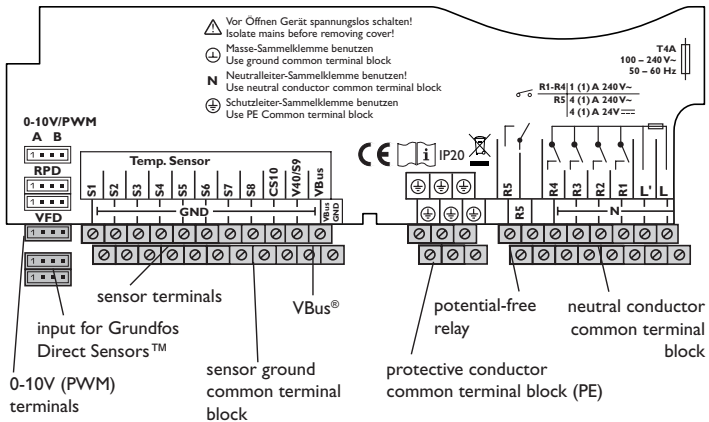

The terminal S9 can be used as an impulse input for V40 flowmeters or as an input for FS08 flow switches.

A **V40** flowmeter can be connected to the terminals S9/V40 and GND (either polarity).

Connect the irradiation sensor **CS10** to the terminals CS10 and GND with correct polarity. To do so, connect the cable marked GND to the GND common terminal block, the cable marked CS to the terminal marked CS10.

In the menu, the irradiation sensor will be indicated as CS10.

The connector marked **PWM/0-10V** contains the 2 PWM/0-10V control signal outputs for high-efficiency pumps or the 0-10V boiler control respectively.

### 0-10V/PWM

A B



1 2 3 4

- 1 = output A, control signal
- 2 = output A, GND
- 3 = output B, GND
- 4 = output B, control signal

In the In-/Outputs menu, relays can be allocated to the PWM outputs.

Connect the **digital Grundfos Direct Sensors™** to the VFD and RPD inputs.

The controller is supplied with power via a mains cable. The power supply of the device must be 100 ... 240V~ (50 ... 60 Hz).

The **mains connection** is to be made at the following terminals:

Neutral conductor N

Conductor L

Protective earth conductor  $\oplus$  (common terminal block)

### WARNING! Electric shock!



L' is a fused contact permanently carrying voltage.

→ **Always disconnect the device from power supply before opening the housing!**

Conductor L' (L' is not connected with the mains cable. L' is a fused contact permanently carrying voltage.)



### Note

For more details about the commissioning procedure see page 14.

### 2.3 Data communication/Bus

The controller is equipped with the VBus® for data transfer and energy supply to external modules. The connection is carried out at the two terminals marked **VBus** and **GND** (either polarity). One or more **VBus**® modules can be connected via this data bus, such as:

- DL2/DL3 Datalogger
- KM2 Communication module
- EM Extension Module
- VBus®/USB or VBus® /LAN interface adapters

Different solutions for visualisation and remote parameterisation are available on the website [www.resol.com](http://www.resol.com).

On the website, firmware updates are also available.



#### Note:

For more information about accessories, see page 64.

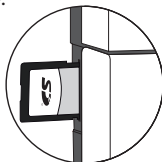

### 2.4 SD card slot

The controller is equipped with an SD card slot.

With an SD card, the following functions can be carried out:

- Store measurement and balance values onto the SD card. After the transfer to a computer, the values can be opened and visualised, e.g. in a spreadsheet.
- Prepare adjustments and parameterisations on a computer and transfer them via the SD card.
- Store adjustments and parameterisations on the SD card and, if necessary, retrieve them from there.
- Download firmware updates from the Internet and install them on the controller.

For more information about using an SD card, see page 57.

## 3 Operation and function

### 3.1 Buttons

The controller is operated via the 7 buttons next to the display. They have the following functions:

Button 1 - scrolling upwards

Button 3 - scrolling downwards

Button 2 - increasing adjustment values

Button 4 - reducing adjustment values

Button 5 - confirming

Button 6 - entering the status menu /chimney sweeper mode or screed drying mode (system-dependent)

Button 7 - escape button for changing into the previous menu

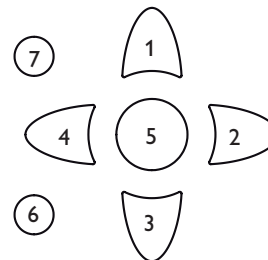

#### Operating control LED (in the directional pad)

Green: Everything OK

Red: Error/cancellation screed drying

Red flashing: Sensor fault, initialisation

Green flashing: Manual mode



### 3.2 Selecting menu points and adjusting values

During normal operation of the controller, the display is in the Status menu. If no button is pressed for a few seconds, the display illumination goes out.

Press any key to reactivate the display illumination.

- In order to scroll through a menu or to adjust a value, press either buttons **1** and **3** or buttons **2** and **4**.
- To open a sub-menu or to confirm a value, press button **5**.
- To re-enter the status menu, press button **6** – unconfirmed adjustments will not be saved.
- To enter the previous menu, press button **7** – unconfirmed adjustments will not be saved.

Use the buttons **2** and **4** for scrolling through the status menu.

HC 1	E 12:23		
▶ Op. mode	Auto	<b>2</b>	
Status	Day		<b>4</b>
Flow	40 °C		

HC 2 static	E 12:23		
▶ Op. mode	Auto		
Status	Summer		
Flow	50 °C		

With the parameters **Mixer** and **HC pump** in the **status menu of the heating circuits**, a shortcut to the **Manual mode** is possible, for example, for carrying out a mixer test.

- In order to enter the **Manual mode**, press button **5**.
- In order to get back to the status menu of the heating circuit, press button **7**.

If no button has been pressed within a couple of minutes, the adjustment is cancelled and the previous value is retained.



#### Note:

After having carried out the adjustments, the controller has to be kept switched-on for at least 2 min for storing the adjustments.

### Chimney sweeper/screed drying

The chimney sweeper or screed drying function can be triggered with the button **6**. The chimney sweeper function is activated by default. In order to activate the screed drying function, the chimney sweeper function must be deactivated in all heating circuits (see page 38).

- In order to trigger the chimney sweeper or screed drying function, press and hold down button **6** for 5 s.

Status: Meas. ...	E 12:05
S1	40.6 °C >>
Flow HC	
HC	

If the symbol **>>** is shown behind a menu item, pressing button **5** will open a new sub-menu.

The symbol **▶** at the edge of the display next to a sensor allocated to a function, means that this sensor has several functions. Use buttons **2** and **4** to scroll to these functions.

Relay selec.	E 12:07
▶ <input type="checkbox"/> Controller	
R1	
R4	

If the symbol **+** is shown in front of a menu item, pressing button **5** will open a new sub-menu. If it is already opened, a **-** is shown instead of the **+**.

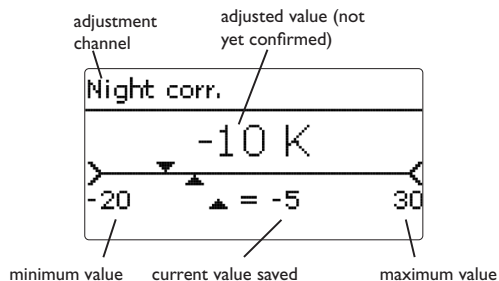

Values and adjustments can be changed in different ways:

Numeric values can be adjusted by means of a slide bar. The minimum value is indicated to the left, the maximum value to the right. The large number above the slide bar indicates the current adjustment. By pressing buttons **2** or **4** the upper slide bar can be moved to the left or to the right.

Only after the adjustment has been confirmed by pressing button **5** will the number below the slide bar indicate the new value. The new value will be saved if it is confirmed by pressing button **5** again.

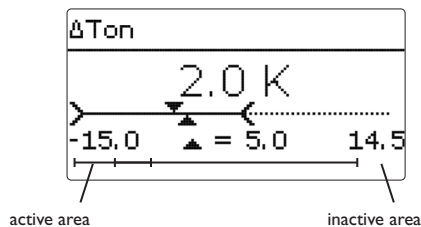

When 2 values are locked against each other, they will display a reduced adjustment range depending on the adjustment of the respective other value.

In this case, the active area of the slide bar is shortened, the inactive area is indicated as a dotted line. The indication of the minimum and maximum values will adapt to the reduction.

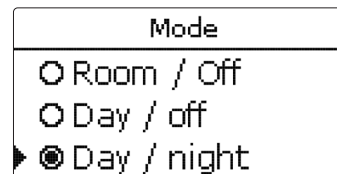

If only one item of several can be selected, they will be indicated with radio buttons. When one item has been selected, the radio button in front of it is filled.

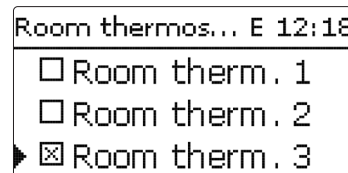

If more than one item of several can be selected, they will be indicated with checkboxes. When an item has been selected, an x appears inside the checkbox.

## Adjusting the timer

When the **Timer** option is activated, a timer is indicated in which time frames for the function can be adjusted.

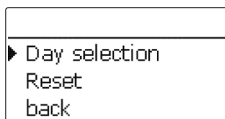

Day selection  
Reset  
back

In the **Day selection** channel, the days of the week are available individually and as frequently selected combinations.

If more than one day or combination is selected, they will be merged into one combination for the following steps.

The last menu item after the list of days is **Continue**. If Continue is selected, the timer menu opens, in which the time frames can be adjusted.

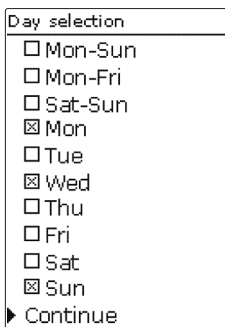

Day selection  
 Mon-Sun  
 Mon-Fri  
 Sat-Sun  
 Mon  
 Tue  
 Wed  
 Thu  
 Fri  
 Sat  
 Sun  
Continue

### Adding a time frame:

In order to add a time frame, proceed as follows:

1. **Select New time frame.**

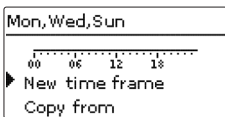

Mon, Wed, Sun  
00 06 12 18  
New time frame  
Copy from

2. **Adjust Start and Stop** for the desired time frame.

The time frames can be adjusted in steps of 5 min.

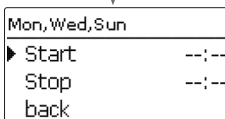

Mon, Wed, Sun  
Start --:--  
Stop --:--  
back

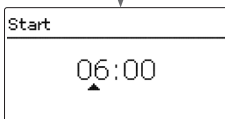

Start  
06:00

3. In order to save the time frame, select **Save** and confirm the security enquiry with **Yes**.

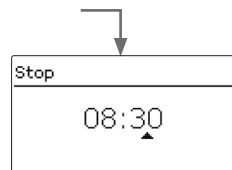

Stop  
08:30

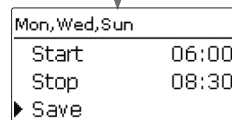

Mon, Wed, Sun  
Start 06:00  
Stop 08:30  
Save

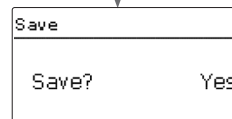

Save  
Save? Yes

4. In order to add another time frame, repeat the previous steps.

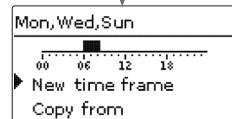

Mon, Wed, Sun  
00 06 12 18  
New time frame  
Copy from

- 6 time frames can be adjusted per day or combination.

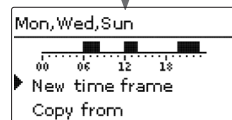

Mon, Wed, Sun  
00 06 12 18  
New time frame  
Copy from

5. Press button **7** in order to get back to the day selection.

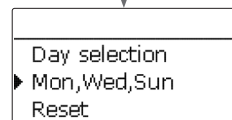

Day selection  
Mon, Wed, Sun  
Reset

## Copying a time frame:

In order to copy time frames already adjusted into another day/another combination, proceed as follows:

1. Choose the day/The combination into which the time frames are to be copied and select **Copy from**.

A selection of days and/or combinations with time frames will appear.

2. Select the day or combination from which the time frames are to be copied.

All time frames adjusted for the selected day or combination will be copied.

If the time frames copied are not changed, the day or combination will be added to the combination from which the time frames have been copied.

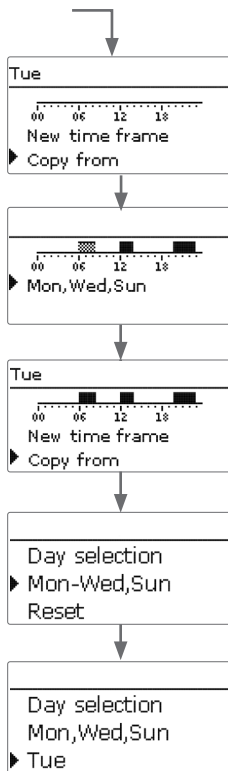

## Changing a time frame:

In order to change a time frame, proceed as follows:

1. Select the time frame to be changed.
2. Make the desired change.
3. In order to save the time frame, select **Save** and confirm the security enquiry with **Yes**.

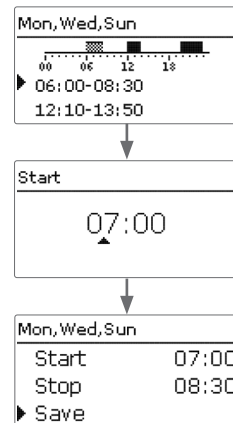

## Removing a time frame:

In order to delete a time frame, proceed as follows:

1. Select the time frame that is to be deleted.
2. Select **Delete** and confirm the security enquiry with **Yes**.

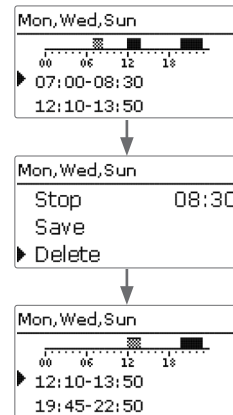

## Resetting the timer:

In order to reset time frames adjusted for a certain day or combination, proceed as follows

1. Select the desired day or combination.

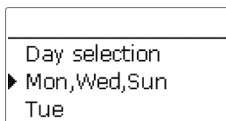

Day selection  
▶ Mon,Wed,Sun  
Tue

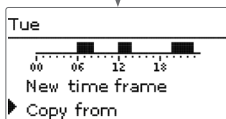

Tue  
00 06 12 18  
New time frame  
▶ Copy from

2. Select **Reset** and confirm the security enquiry with **Yes**.

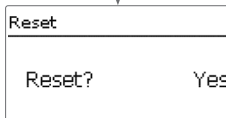

Reset  
Reset? Yes

The selected day or combination will disappear from the list, all its time frames will be deleted.

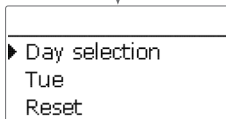

▶ Day selection  
Tue  
Reset

In order to reset the whole timer, proceed as follows:

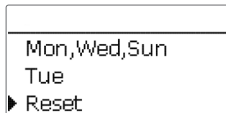

Mon,Wed,Sun  
Tue  
▶ Reset

- Select **Reset** and confirm the security enquiry with **Yes**.

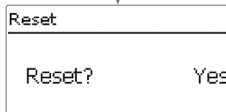

Reset  
Reset? Yes

All adjustments made for the timer are deleted.

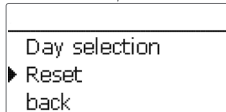

Day selection  
▶ Reset  
back

## 4 Commissioning

When the hydraulic system is filled and ready for operation, connect the controller to the mains.

The controller runs an initialisation phase in which the directional pad flashes red. When the controller is commissioned or when it is reset, it will run a commissioning menu after the initialisation phase. The commissioning menu leads the user through the most important adjustment channels needed for operating the system.

### Commissioning menu

The commissioning menu consists of the channels described in the following. In order to make an adjustment, press button **5**. Adjust the value by pressing buttons **2** and **4**, then press button **5** to confirm. The next channel will appear in the display.

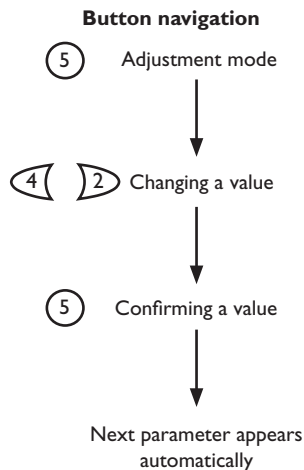

### 1. Language:

→ Adjust the desired menu language.

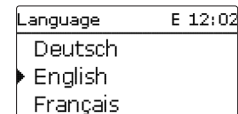

### 2. Units:

→ Adjust the desired temperature unit.

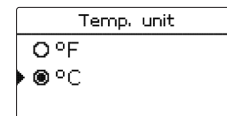

→ Adjust the desired volume unit.

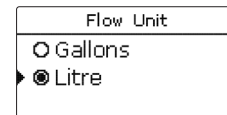

→ Adjust the desired pressure unit.

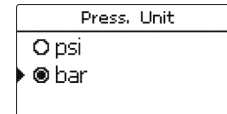

→ Adjust the desired energy unit.

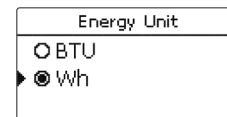

### 3. Daylight savings time adjustment:

- Activate or deactivate the automatic daylight savings time adjustment.

Auto DST
<input checked="" type="radio"/> Yes
<input type="radio"/> No

### 4. Time:

- Adjust the clock time. First of all adjust the hours, then the minutes.

Time
12:02

### 5. Date:

- Adjust the date. First of all adjust the year, then the month and then the day.

Date
?? ?? 2015

### 6. Basic system

- Adjust the desired scheme (heating circuit, demand, DHW heating).

Scheme	E 12:02
Scheme 0	
Scheme 1	
▶ Scheme 2	

Scheme 2	
Save?	Yes

### 7. Completing the commissioning menu:

After the scheme has been selected, a security enquiry appears. If the security enquiry is confirmed, the adjustments are saved.

- In order to confirm the security enquiry, press button 5.
- In order to get back to the commissioning menu channels, press button 7.

After you have confirmed the security enquiry, the controller is ready for operation and normally the factory settings will give close to optimum operation.



#### Note:

The adjustments carried out during commissioning can be changed any-time in the corresponding adjustment channel.

Additional functions and options can also be activated or deactivated.

**Set the code to the customer code before handing over the controller to the customer (see page 58).**

## 4.1 Schemes with basic settings

The controller is preprogrammed for 9 basic systems. The basic pre-adjustments have already been made. For backup heating it is necessary to allocate the demand and the boiler loading pump by means of shared relays. Afterwards the system can easily be extended.

Relay and sensor allocation correspond to the figures.

Scheme 0 has no pre-adjustments.

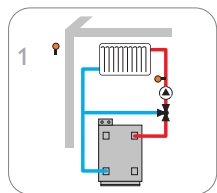

1 mixed heating circuit

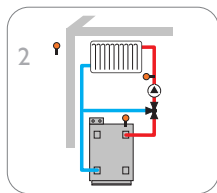

1 mixed heating circuit with backup heating

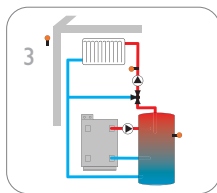

1 mixed heating circuit with backup heating and loading pump

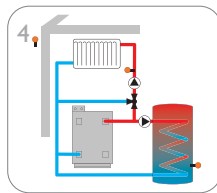

1 mixed heating circuit with DHW heating

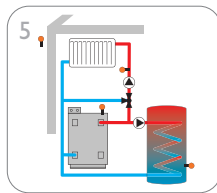

1 mixed heating circuit with DHW heating and backup heating

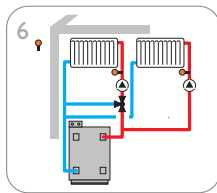

1 mixed and 1 unmixed heating circuit

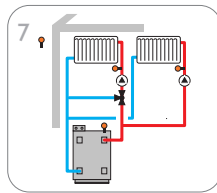

1 mixed and 1 unmixed heating circuit with backup heating

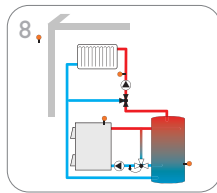

1 mixed heating circuit with solid fuel boiler

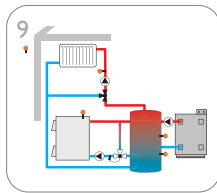

1 mixed heating circuit with solid fuel boiler and backup heating

## 4.2 ErP temperature controls classes

Basic systems with backup heating (schemes 2, 3, 5, 7, and 9) fulfil the requirements of the temperature controls class III according to the ErP Directive.

Further schemes with pre-programmed settings for 0-10 V boiler control, room influence or room control are also available to fulfil the requirements of other temperature controls classes.

For this purpose, the scheme number is extended to 3 digits. The first digit indicates the temperature controls class, the second and the third one indicate the desired basic system.

Example:

In order to select scheme 3 with the settings for temperature controls class VIII, enter the scheme number 803.

<b>8</b>	<b>0</b>	<b>3</b>
Temperature controls class	Number of the desired scheme; with a 0 in front of it for numbers with 1 digit.	

The settings for the different temperature classes will in the following be indicated with digit symbols:

- ②: Temperature controls class II
- ③: Temperature controls class III
- ⑤: Temperature controls class V
- ⑥: Temperature controls class VI
- ⑦: Temperature controls class VII
- ⑧: Temperature controls class VIII

The schemes extended can be found below the scheme 9 in the selection.

Scheme	E 12:18
Scheme 9	
Scheme 202	
▶	Scheme 203



## Scheme 1: 1 mixed heating circuit

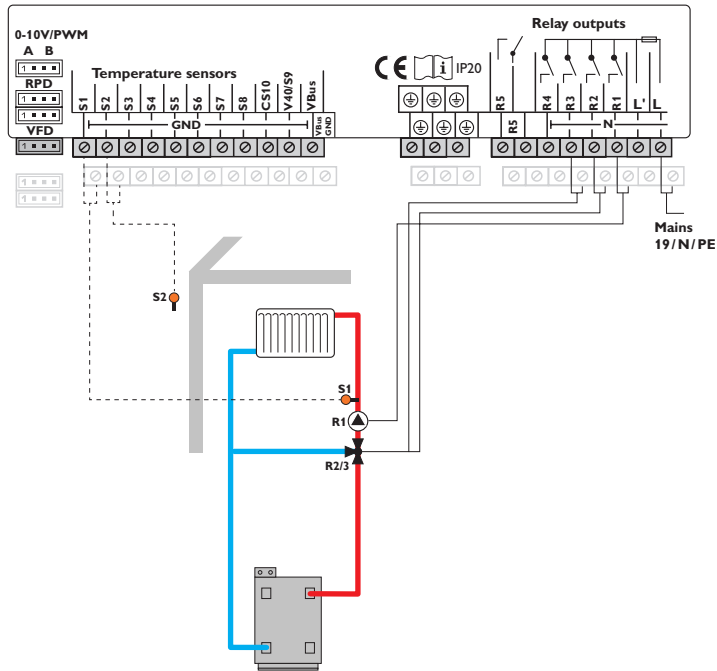

### Sensors

S1	Flow HC1	1/GND
S2	Outdoor	2/GND
S3	Free	3/GND
S4	Free	4/GND
S5	Free	5/GND
S6	Free	6/GND
S7	Free	7/GND
S8	Free	8/GND

### Relay

R1	Pump HC1	17/N/PE
R2	Mixer open	16/N/PE
R3	Mixer closed	15/N/PE
R4	Free	14/N/PE
R5	Free	13/12

### 0-10 V/PWM

A	Free	A
B	Free	B

By means of the flow sensor S1 and the outdoor temperature sensor S2, a mixed weather-compensated heating circuit can be controlled.

## Scheme 2: 1 mixed heating circuit with backup heating (demand)

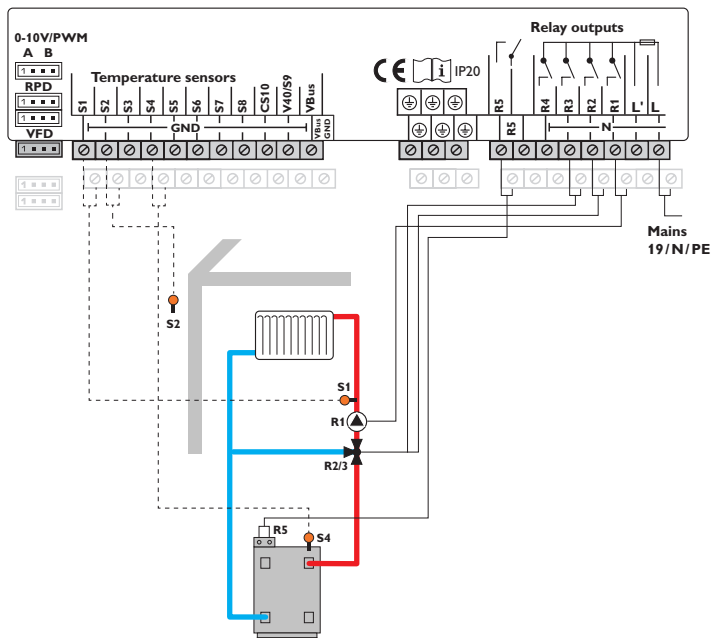

### Sensors

S1	Flow HC1		1/GND
S2	Outdoor	② ③ ⑥ ⑦	2/GND
S3	Free		3/GND
S4	Backup heating/ boiler		4/GND
S5	Free		5/GND
S6	RTH1	⑤ ⑥ ⑦ ⑧	6/GND
S7	RTH2	⑧	7/GND
S8	RTH3	⑧	8/GND

### Relay

R1	Pump HC1		17/N/PE
R2	Mixer open		16/N/PE
R3	Mixer closed		15/N/PE
R4	Free		14/N/PE
R5	Demand	③ ⑦	13/12

### 0-10 V/PWM

A	0-10V	② ⑤ ⑥ ⑧	A
B	Free		B

By means of the flow sensor S1 and the outdoor temperature sensor S2, a mixed weather-compensated heating circuit can be controlled. Boiler demand via the potential-free relay is triggered depending on the temperature difference between the set flow temperature and the value measured at the backup heating sensor S4.

② **Scheme 202:** 0-10 V boiler control, weather-compensated

⑤ **Scheme 502:** 0-10 V boiler control, room control with room temperature sensor S6, no outdoor temperature sensor

⑥ **Scheme 602:** 0-10 V boiler control, room influence with room temperature sensor S6, weather-compensated

⑦ **Scheme 702:** Room influence with room temperature sensor S6, weather-compensated

⑧ **Scheme 802:** 0-10 V boiler control, room control with room temperature sensors S6, S7, S8, no outdoor temperature sensor

### Scheme 3: 1 mixed heating circuit with backup heating (demand and boiler loading pump)

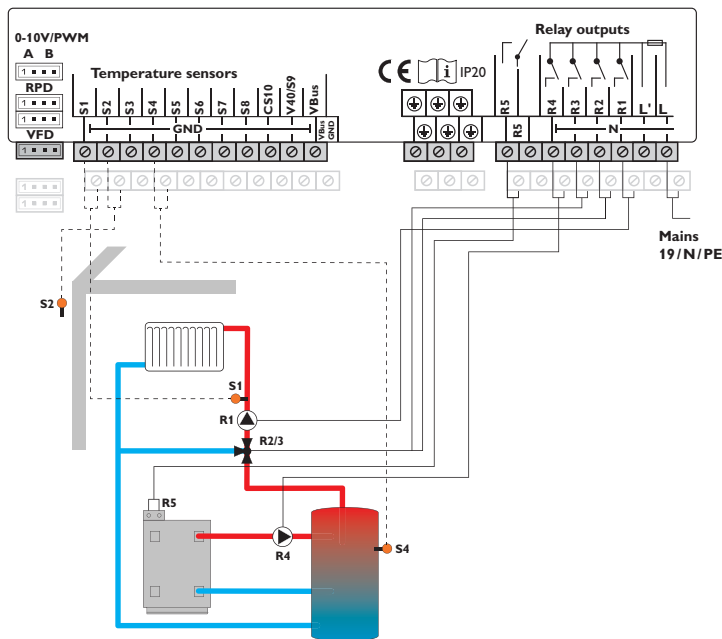

#### Sensors

S1	Flow HC1		1/GND
S2	Outdoor	② ③ ⑥ ⑦	2/GND
S3	Free		3/GND
S4	Backup heating/ boiler		4/GND
S5	Free		5/GND
S6	RTH1	⑤ ⑥ ⑦ ⑧	6/GND
S7	RTH2	⑧	7/GND
S8	RTH3	⑧	8/GND

#### Relay

R1	Pump HC1		17/N/PE
R2	Mixer open		16/N/PE
R3	Mixer closed		15/N/PE
R4	Boiler loading pump		14/N/PE
R5	Demand	③ ⑦	13/12

#### 0-10 V/PWM

A	0-10 V	② ⑤ ⑥ ⑧	A
B	Free		B

By means of the flow sensor S1 and the outdoor temperature sensor S2, a mixed weather-compensated heating circuit can be controlled. Boiler demand via the potential-free relay and boiler loading pump control are triggered depending on the temperature difference between the set flow temperature and the value measured at the backup heating sensor S4.

② **Scheme 203:** 0-10 V boiler control, weather-compensated

⑤ **Scheme 503:** 0-10 V boiler control, room control with room temperature sensor S6, no outdoor temperature sensor

⑥ **Scheme 603:** 0-10 V boiler control, room influence with room temperature sensor S6, weather-compensated

⑦ **Scheme 703:** Room influence with room temperature sensor S6, weather-compensated

⑧ **Scheme 803:** 0-10 V boiler control, room control with room temperature sensors S6, S7, S8, no outdoor temperature sensor

## Scheme 4: 1 mixed heating circuit with DHW heating

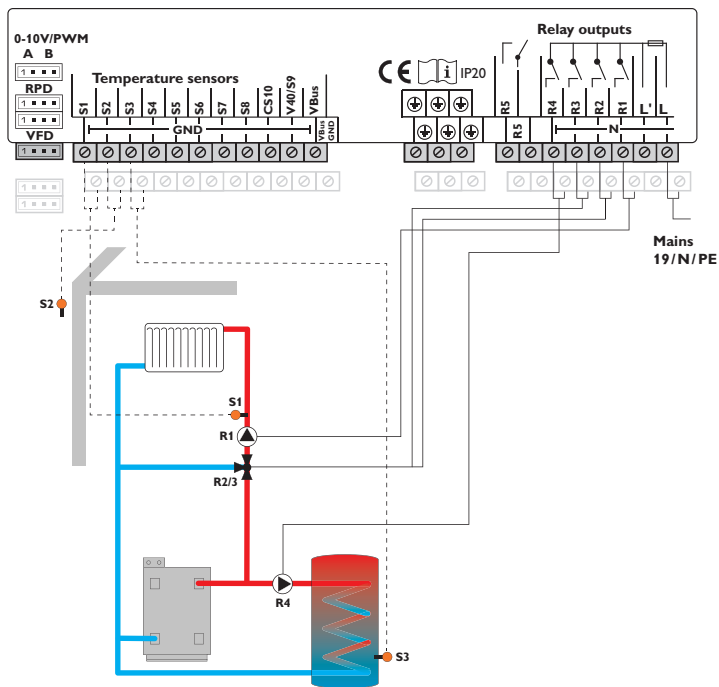

### Sensors

S1	Flow HC1	1/GND
S2	Outdoor	2/GND
S3	DHW	3/GND
S4	Free	4/GND
S5	Free	5/GND
S6	Free	6/GND
S7	Free	7/GND
S8	Free	8/GND

### Relay

R1	Pump HC1	17/N/PE
R2	Mixer open	16/N/PE
R3	Mixer closed	15/N/PE
R4	DHW loading pump	14/N/PE
R5	Free	13/12

### 0-10 V/PWM

A	Free	A
B	Free	B

By means of the flow sensor S1 and the outdoor temperature sensor S2, a mixed weather-compensated heating circuit can be controlled. DHW heating is triggered depending on the value measured at the DHW sensor S3.

## Scheme 5: 1 mixed heating circuit with DHW heating and backup heating (demand for heating circuit and DHW)

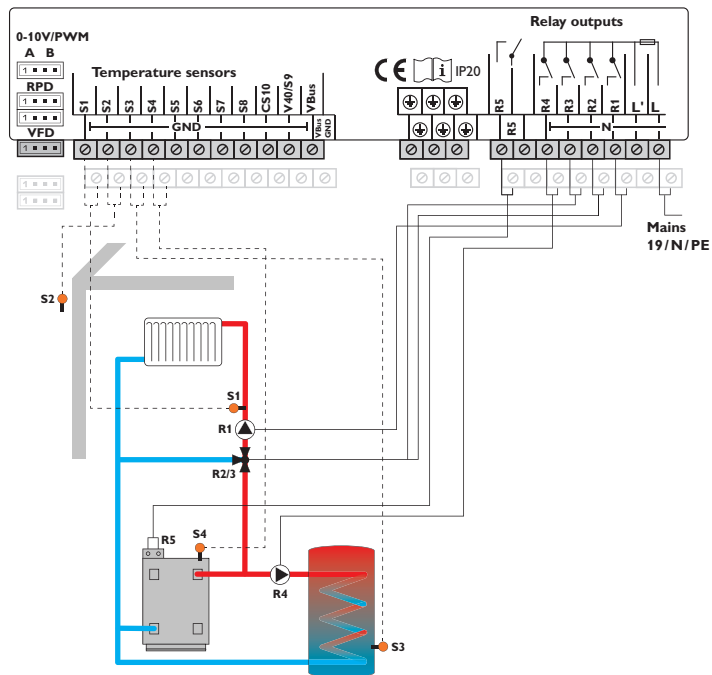

Sensors		
S1	Flow HC1	1/GND
S2	Outdoor	② ③ ⑥ ⑦ 2/GND
S3	DHW	3/GND
S4	Backup heating/ boiler	4/GND
S5	Free	5/GND
S6	RTH1	⑤ ⑥ ⑦ ⑧ 6/GND
S7	RTH2	⑧ 7/GND
S8	RTH3	⑧ 8/GND

Relay		
R1	Pump HC1	17/N/PE
R2	Mixer open	16/N/PE
R3	Mixer closed	15/N/PE
R4	DHW loading pump	14/N/PE
R5	Demand	③ ⑦ 13/12

0-10 V/PWM		
A	0-10V	② ⑤ ⑥ ⑧ A
B	Free	B

By means of the flow sensor S1 and the outdoor temperature sensor S2, a mixed weather-compensated heating circuit can be controlled. DHW heating is triggered depending on the value measured at the DHW sensor S3. Boiler demand via the potential-free relay is triggered depending on the temperature difference between the set flow temperature and the value measured at the backup heating sensor S4. Boiler demand can also be triggered by the temperature difference between the DHW set temperature and the backup heating sensor S3.

② **Scheme 205:** 0-10 V boiler control, weather-compensated

⑤ **Scheme 505:** 0-10 V boiler control, room control with room temperature sensor S6, no outdoor temperature sensor

⑥ **Scheme 605:** 0-10 V boiler control, room influence with room temperature sensor S6, weather-compensated

⑦ **Scheme 705:** Room influence with room temperature sensor S6, weather-compensated

⑧ **Scheme 805:** 0-10 V boiler control, room control with room temperature sensors S6, S7, S8, no outdoor temperature sensor

## Scheme 6: 1 mixed and 1 unmixed heating circuit

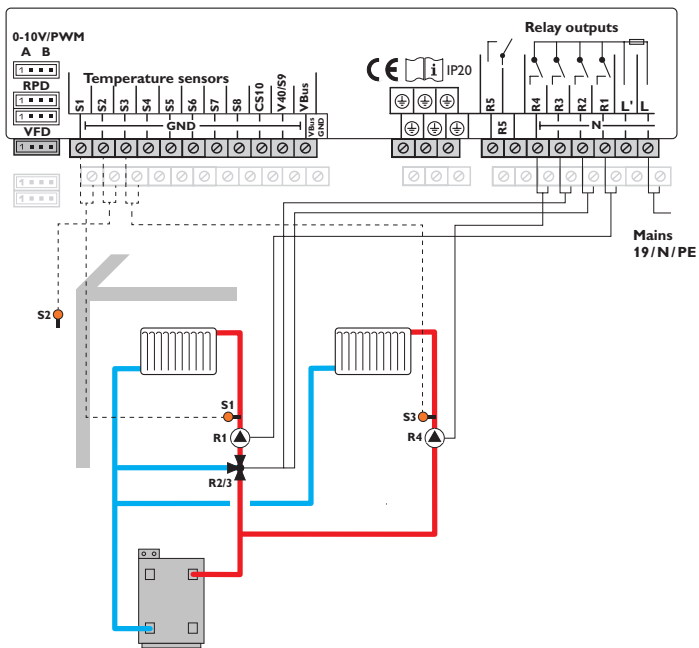

### Sensors

S1	Flow HC1	1/GND
S2	Outdoor	2/GND
S3	Flow HC2	3/GND
S4	Free	4/GND
S5	Free	5/GND
S6	Free	6/GND
S7	Free	7/GND
S8	Free	8/GND

### Relay

R1	Pump HC1	17/N/PE
R2	Mixer open	16/N/PE
R3	Mixer closed	15/N/PE
R4	Pump HC2	14/N/PE
R5	Free	13/12

### 0-10 V/PWM

A	Free	A
B	Free	B

By means of the flow sensors S1 and S3 and the outdoor temperature sensor S2, a mixed and an unmixed weather-compensated heating circuit can be controlled.

## Scheme 7: 1 mixed and 1 unmixed heating circuit with backup heating (demand)

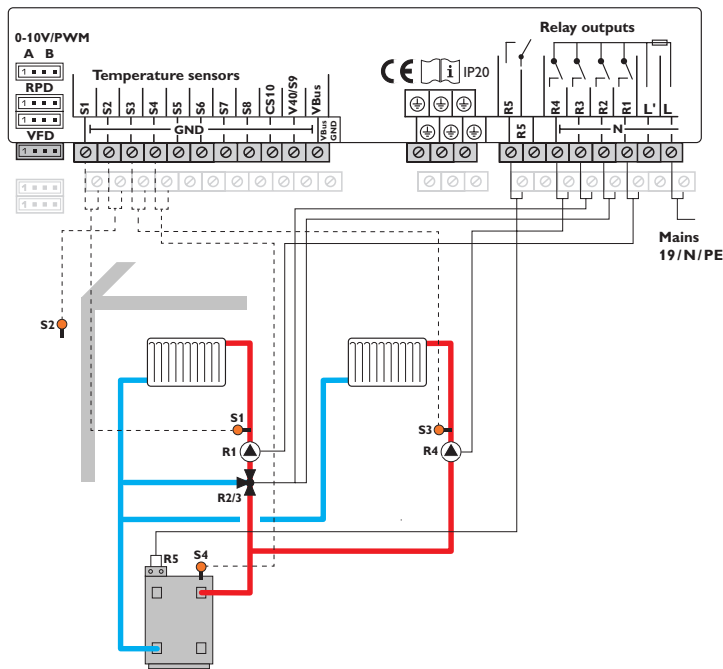

### Sensors

S1	Flow HC1		1/GND
S2	Outdoor	② ③ ⑥ ⑦	2/GND
S3	Flow HC2		3/GND
S4	Backup heating/ boiler		4/GND
S5	Free		5/GND
S6	RTH1	⑤ ⑥ ⑦ ⑧	6/GND
S7	RTH2	⑧	7/GND
S8	RTH3	⑧	8/GND

### Relay

R1	Pump HC1		17/N/PE
R2	Mixer open		16/N/PE
R3	Mixer closed		15/N/PE
R4	Pump HC2		14/N/PE
R5	Demand	③ ⑦	13/12

### 0-10 V/PWM

A	0-10 V	② ⑤ ⑥ ⑧	A
B	Free		B

By means of the flow sensors S1 and S3 and the outdoor temperature sensor S2, a mixed and an unmixed weather-compensated heating circuit can be controlled. Boiler demand via the potential-free relay is triggered depending on the temperature difference between the set flow temperatures and the value measured at the backup heating sensor S4.

② **Scheme 207:** 0-10 V boiler control, weather-compensated

⑤ **Scheme 507:** 0-10 V boiler control, room control with room temperature sensor S6, no outdoor temperature sensor

⑥ **Scheme 607:** 0-10 V boiler control, room influence with room temperature sensor S6, weather-compensated

⑦ **Scheme 707:** Room influence with room temperature sensor S6, weather-compensated

⑧ **Scheme 807:** 0-10 V boiler control, room control with room temperature sensors S6, S7, S8, no outdoor temperature sensor

## Scheme 8: 1 mixed heating circuit with solid fuel boiler

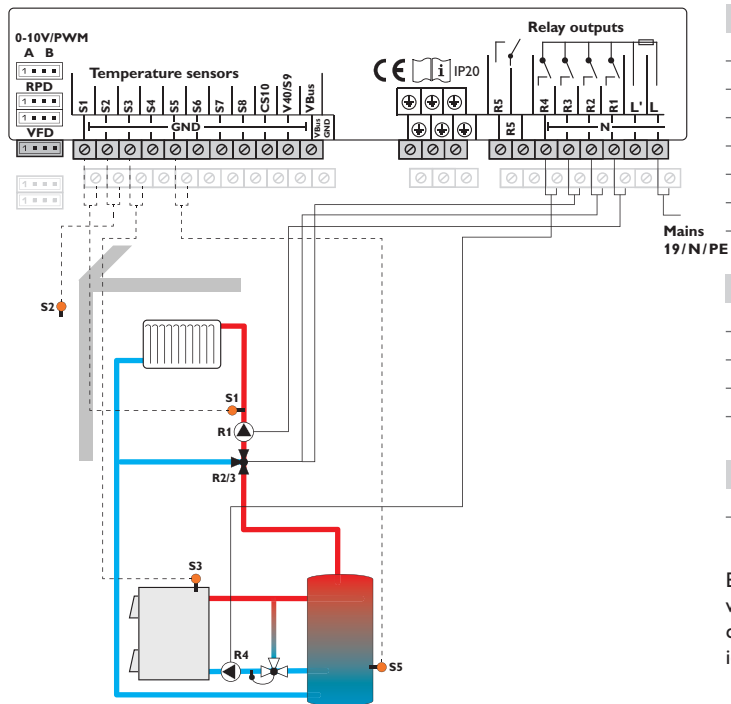

### Sensors

S1	Flow HC1	1/GND
S2	Outdoor	2/GND
S3	Solid fuel boiler	3/GND
S4	Free	4/GND
S5	Store	5/GND
S6	Free	6/GND
S7	Free	7/GND
S8	Free	8/GND

### Relay

R1	Pump HC1	17/N/PE
R2	Mixer open	16/N/PE
R3	Mixer closed	15/N/PE
R4	Pump SFB	14/N/PE
R5	Free	13/12

### 0-10 V/PWM

A	Free	A
B	Free	B

By means of the flow sensor S1 and the outdoor temperature sensor S2, a mixed weather-compensated heating circuit can be controlled. The solid fuel boiler is controlled depending on the temperature difference between the sensors S3 (solid fuel boiler) and S5 (store).



## Scheme 9: 1 mixed heating circuit with solid fuel boiler and backup heating (demand)

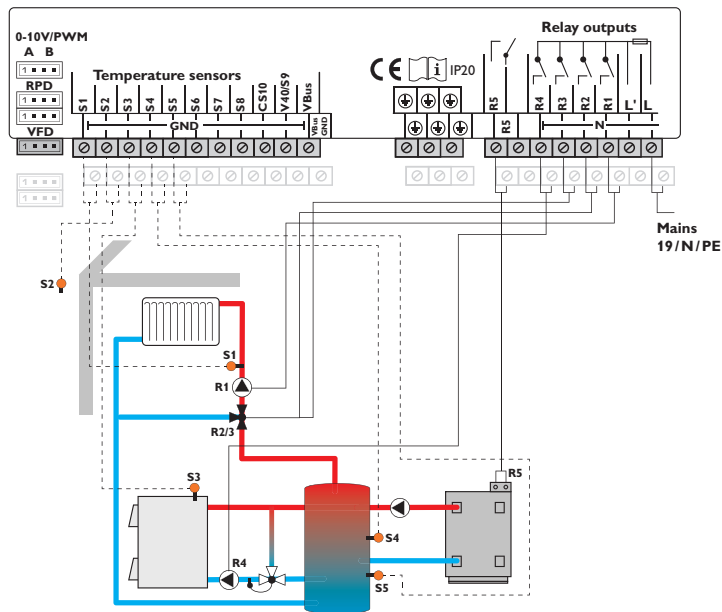

### Sensors

S1	Flow HC1		1/GND
S2	Outdoor	② ③ ⑥ ⑦	2/GND
S3	Solid fuel boiler		3/GND
S4	Backup heating/ boiler		4/GND
S5	Store		5/GND
S6	RTH1	⑤ ⑥ ⑦ ⑧	6/GND
S7	RTH2	⑧	7/GND
S8	RTH3	⑧	8/GND

### Relay

R1	Pump HC1		17/N/PE
R2	Mixer open		16/N/PE
R3	Mixer closed		15/N/PE
R4	Pump SFB		14/N/PE
R5	Demand	③ ⑦	13/12

### 0-10 V/PWM

A	0-10 V	② ⑤ ⑥ ⑧	A
B	Free		B

By means of the flow sensor S1 and the outdoor temperature sensor S2, a mixed weather-compensated heating circuit can be controlled. Boiler demand via the potential-free relay is triggered depending on the temperature difference between the set flow temperature and the value measured at the backup heating sensor S4. The solid fuel boiler is controlled depending on the temperature difference between the sensors S3 (solid fuel boiler) and S5 (store).

② **Scheme 209:** 0-10 V boiler control, weather-compensated

⑤ **Scheme 509:** 0-10 V boiler control, room control with room temperature sensor S6, no outdoor temperature sensor

⑥ **Scheme 609:** 0-10 V boiler control, room influence with room temperature sensor S6, weather-compensated

⑦ **Scheme 709:** Room influence with room temperature sensor S6, weather-compensated

⑧ **Scheme 809:** 0-10 V boiler control, room control with room temperature sensors S6, S7, S8, no outdoor temperature sensor

## 4.3 Step-by-step parameterisation

The heating controller *DeltaTherm*® HC is a controller that offers a broad variety of functions to the user. At the same time, the user has a lot of freedom in configuring them. Therefore, to set up a complex system, careful planning is required. We recommend drawing a sketch of the system first.

If planning, hydraulic construction and electrical connection have all been carried out successfully, proceed as follows:



### Note:

For further information about the ErP temperature controls classes see page 16.

### 1. Running the commissioning menu

After the commissioning menu has been finished (see page 14), further adjustments can be made. The commissioning menu can be repeated any time by means of a reset (see page 56). Additional adjustments will be deleted.

### 2. Registering modules and sensors

If a flowmeter, switch, Grundfos Direct Sensors™ and/or external extension modules are connected, these have to be registered in the In-/Outputs menu.

For further information about the registration of modules and sensors see page 59.

### 3. Adjusting heating circuits and activating optional heating functions

Now, further heating circuits can be activated and adjusted.

For the heating part of the arrangement, optional functions can be selected, activated and adjusted.

- DHW heating
- Circulation
- Thermal disinfection

Heating circuits and their optional functions can use shared relays for (boiler) demands, loading pumps or valves. They have to be selected in the **Shared relays** menu first (see page 30). All free relays available on the controller and on the modules connected can be used.

The controller always suggests the numerically smallest free relay.

Sensors can be allocated to more than one function.

For further information about heating circuits and optional heating functions see page 41.

### 4. Adjusting the operating mode

After commissioning the heating circuit will be in automatic mode. The operating mode can be changed in the status menu:

- Automatic
- Day
- Night
- Summer
- Holiday
- Off

The operating mode of the first heating circuit also applies to all further heating circuits (via extension modules), if they are linked. If you wish to operate one of the heating circuits 2...7 independently, deactivate the linking of the corresponding heating circuit (see page 38).

### 5. Activating optional arrangement functions

Now, optional functions for the arrangement can be selected, activated and adjusted:

- Heat exchange
- Return preheating
- Solid fuel boiler
- Mixer
- Parallel relay
- Irradiation switch
- Zone loading
- Error relay
- Function block

Free relays can be allocated to optional functions which require a relay. The controller always suggests the numerically smallest free relay.

Sensors can be allocated to more than one function.

For further information about the optional arrangement functions see page 46.

## 5 Functions and options

### 5.1 Menu structure

#### Main menu

Status

Heating

Arrangement

HQM

Basic settings

SD card

Manual mode

User code

In-/Outputs

#### Heating

System

Shared relays

Heating circuits

Optional functions

Screed drying

#### Arrangement

Optional functions

#### Basic settings

Language

Temp. Unit

Flow Unit

Press. Unit

Energy Unit

Auto DST

Time

...

Scheme

Reset

#### In-/Outputs

Modules

Inputs

Outputs

#### Shared rel.

Demand 1

Demand 2

Pump 1

Pump 2

Valve 1

Valve 2

#### Optional functions

DHW heating

Th. Disinfection

Circulation

#### Optional functions

Heat exchange

Return preheating

Solid fuel boiler

Mixer

Parallel relay

Irradiation switch

Zone loading

Error relay

Function block

#### Demand 1

Relay

0-10V

Minimum runtime



The menu items and adjustment values selectable are variable depending on adjustments already made. The figure only shows an exemplary excerpt of the complete menu in order to visualise the menu structure.

## 5.2 Status menu

Status	E 12:19
▶ Heating	
HC	>>
DHW heating	>>

The status menu contains information about the current states of all activated heating circuits, optional functions and HQM. Furthermore, measured and balance values as well as messages are indicated.

Use the buttons  and  for scrolling through the status menu.

HC 1	E 12:23		HC 2 static	E 12:23
▶ Op. mode	Auto		▶ Op. mode	Auto
Status	Day		Status	Summer
Flow	40 °C		Flow	50 °C

## 5.3 Heating

HC 1	E 12:23
▶ Op. mode	Auto
Status	Day
Flow	40 °C

In the **Status/Heating** menu, the status of the heating circuits activated as well as of the selected optional functions is indicated.

The status of the first heating circuit is also the home screen of the controller. In this menu, the operating mode of the heating circuit can be changed:

**Automatic:** Automatic heating mode with optionally activated DHW heating and circulation.

**Day:** Constant heating mode with the adjusted day correction.

**Night:** Constant heating mode with the adjusted night correction and the selected correction mode.

**Summer:** The heating circuit is switched off. The optionally activated DHW heating and circulation remain active.

**Off:** The heating circuit as well as the optionally activated DHW heating and circulation are switched off.

**Holiday:** Constant heating mode within an adjustable time frame with the adjusted night correction and the selected correction mode.

Days of absence
7 d
▶ ◀
0 ▲ = 0 ▼ 200

If the operating mode **Holiday** is selected, the adjustment channel **Holiday** will appear for adjusting the days of an absence. The day, on which the adjustment is made, is the first day of absence. The days will be counted backwards at 00:00. The remaining days are indicated in the status menu (countdown). If 0 is reached, the controller automatically switches to the operating mode Automatic.

The operating mode of the first heating circuit also applies to all further heating circuits (via extension modules), if they are linked. If you wish to operate one of the heating circuits 2...7 independently, deactivate the linking of the corresponding heating circuit (see page 38).

## 5.4 Arrangement

Solid fuel boiler	E 12:24
▶ Status	Active
SBoiler	75 °C
Store	45 °C

In the **Status/Arrangement** menu, the status information (Active, Inactive, Deactivated), the temperatures of the relevant sensors and the relays states are indicated.

HQM	E 12:25
▶ Status	Active
Sen. Flow	42 °C
Sen. Return	23 °C

In the **Status/HQM** menu, all current measured values of the flow and return sensors, flow rate and power as well as heat quantity are indicated.

### 5.6 Meas./Balance values

In the **Status/Meas./Balance** menu, all current measurement values as well as a range of balance values are displayed. Some of the menu items can be selected in order to enter a sub-menu.

Each sensor and relay is indicated with the component or function it has been allocated to. The symbol ▶ at the edge of the display next to a sensor allocated to a function, means that this sensor has several functions. Use buttons **2** and **4** to scroll to these functions. The sensors and relays of the controller and all modules connected are listed in numerical order.

Status: Meas. ...	E 12:05
S1	40.6 °C ▶▶
Flow HC	
HC	

When a line with a measurement value is selected, another sub-menu will open.

S1	E 12:25
▶ Minimum	23.2 °C
Maximum	46.4 °C
back	

If, for example, **S1** is selected, a sub-menu indicating the minimum and maximum values will open.

Status: Messages	E 12:26
▶ Everything OK	
Version	1.09
back	

In the **Status/ Messages** menu, error and warning messages are indicated. During normal operation, the message **Everything OK** is indicated.

A line break or short circuit in a sensor line is indicated as **!Sensor fault**. A precise error code can be found in the Status/Meas.-/Balance values menu.

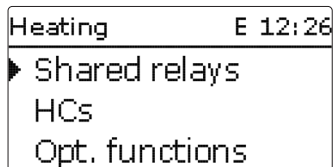

In this menu, all adjustments for the heating part of the arrangement or for the heating circuits respectively can be made.

Shared relays for demands, loading pumps or valves can be activated, heating circuits can be configured and optional functions can be selected and adjusted.

In this menu, the screed drying function can be activated and adjusted.

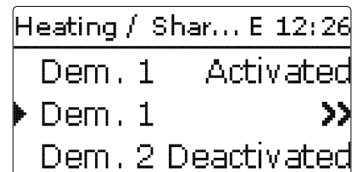
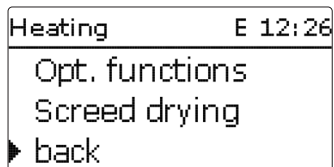

In this menu, adjustments for heat generators, loading pumps and valves which are shared by several heating circuits and their optional functions can be made.

Further options such as boiler protection, start-up and overrun are also available.

Shared relays will be available for selection under **Virtual** in the heating circuits and in the relay allocation channels of the corresponding optional functions of the Heating menu. This way, several heating circuits and optional functions (heating) can demand the same heat source, use the same loading pump or switch a shared relay (e. g. a valve).

**Note:**

Activate and adjust the shared relays first. They will then be available in the heating circuits and optional functions.

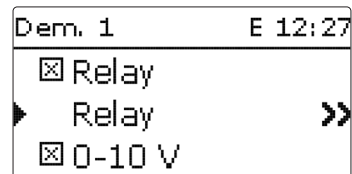

## Heating/Shared rel.

Adjustment channel	Description	Adjustment range / selection	Factory setting
Dem. 1 (2)	Demand 1 (2)	Activated, Deactivated	Deactivated
Relay	Relay option	Yes, No	No
Relay	Relay sub-menu	-	-
Output	Output selection	system dependent	R5
Boiler pr. min	Option for boiler protection min	Yes, No	No
Tmin	Minimum boiler temperature	10 ... 90 °C	55 °C
Boiler pr. max	Option for boiler protection max	Yes, No	No
Tmax	Maximum boiler temperature	20 ... 95 °C	90 °C
Sensor Boiler	Boiler sensor selection	system dependent	S4
0-10V	0-10V option	Yes, No	No
0-10V	0-10V sub-menu	-	-
Output	Output selection	-, A, B	D
Tset 1	Lower boiler temperature	10 ... 90 °C	10 °C
Volt 1	Lower voltage	0.0 ... 10.0 V	1.0 V
Tset 2	Upper boiler temperature	10 ... 90 °C	80 °C
Volt 2	Upper voltage	0.0 ... 10.0 V	8.0 V
Tmin	Minimum boiler temperature	1 ... 90 °C	10 °C
Tmax	Maximum boiler temperature	1 ... 90 °C	80 °C
Sen. Flow	Flow sensor option	Yes, No	No
Sensor	Flow sensor selection	system dependent	S4
Interval	Monitoring period	10 ... 600 s	30 s
Hysteresis	Correction hysteresis	0.5 ... 20.0 K	1.0 K
Correction	Correction of the voltage signal	0.1 ... 1.0 V	0.1 V
Min. runtime	Minimum runtime option	Yes, No	No
Min. runtime	Minimum runtime	0 ... 120 min	10 min
Pump 1 ... 2	Shared relay option for loading pump	Activated, Deactivated	Deactivated
Relay	Relay selection	system dependent	system dependent
Start-up	Pump delay	No, Time, Temperature	No
Delay	Delay to a demand	0 ... 300 s	60 s
TStart-up	Boiler start-up temperature	10 ... 90 °C	60 °C
Overrun	Pump overrun	No, Time, Temperature	No

Adjustment channel	Description	Adjustment range / selection	Factory setting
Overrun time	Overrun time	0 ... 300 s	60 s
TOverrun	Remaining boiler temperature	10 ... 90 °C	50 °C
Sensor Boiler 1 ... 2	Boiler sensor selection	system dependent	system dependent
Valve 1 ... 2	Activation of a shared relay Parallel relay	Activated, Deactivated	Deactivated
Relay	Relay selection	system dependent	system dependent

In this menu, up to 2 heating demands can be activated and adjusted.

**Activated demands will be available for selection in the output allocation channels of the backup heating in heating circuits and heating optional functions. This way, several heating circuits and optional functions can demand the same heat source.**

Every demand can be carried out by means of a relay and/or a 0-10 V output. If both the Relay and the 0-10 V option are activated, the demand will use both outputs in parallel.

### Relay option

If the **Relay** option is activated, the sub-menu **Relay** appears, in which a relay can be allocated to the demand.

The options **Boiler protection min** and **Boiler protection max** can be activated for the demand via a relay, allowing temperature-dependent control of the boiler demand. For this purpose, a boiler sensor (**Sensor Boiler**) is required.

The **Boiler pr. min** option is used for protecting an older type boiler against cooling. If the temperature falls below the adjusted minimum temperature, the allocated relay is energised until the minimum temperature is exceeded by 2 K.

The **Boiler pr. max** option is used for protecting an older type boiler against overheating. If the adjusted maximum temperature is exceeded, the allocated relay is switched off until the temperature falls by 2 K below the maximum temperature.

Example:

The potential-free relay R5 can be allocated to the demand. R5 will then become available for potential-free boiler demand in the heating circuits and e. g. the DHW heating function.

**Example:**

The potential-free relay R5 can be allocated to the shared relay **Demand 1**. R5 will then become available for potential-free boiler demand in the heating circuits and e. g. the DHW heating function (scheme 5).

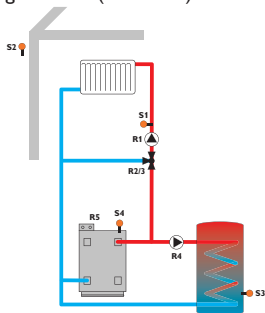
**0-10V option**

If the **0-10V** option is activated, the sub-menu 0-10V will appear, in which a 0-10V output can be allocated to the demand.

With this option, the controller can demand modulating heat generators equipped with a 0-10V interface.

The characteristic curve of the 0-10V signal as a function of the set boiler temperature are defined by means of 2 set points according to the specifications of the boiler manufacturer. At a temperature of **Tset 1**, the voltage signal of the heat generator is **Volt 1**. At a temperature of **Tset 2**, the voltage signal of the heat generator is **Volt 2**. The controller automatically calculates the characteristic curve resulting from these values.

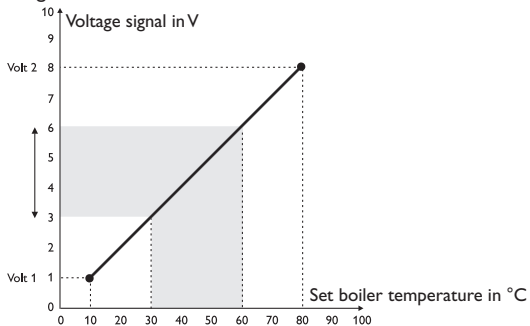

By means of the adjustment channels **Tmax** and **Tmin** the maximum and minimum limitations for the set boiler temperature can be defined.

When the **Sensor flow** option is activated, the controller will monitor whether the heat generator actually reaches the desired set temperature and will, if necessary, adjust the voltage signal accordingly. In order to do so, the controller will check the temperature at the boiler flow sensor when the **Interval** has elapsed. If the temperature measured deviates from the set boiler temperature by more than the **Hysteresis** value, the voltage signal will be adapted by the **Correction** value. This process will be repeated until the temperature measured is identical to the set boiler temperature.

When the **Min. runtime** option is activated, a **Minimum runtime** can be adjusted for the demand.

**Note:**

If the 0-10V demand is used for DHW heating, the voltage signal will always be identical to **Tmax**.

**Pump**

For loading pumps, the shared relays **Pump 1** and **Pump 2** are available. Concerning a demand, the options **Start-up** and **Overrun** can be activated for the shared relays. The demand can either be time- or temperature controlled. For temperature-dependent control an allocated boiler sensor is required.

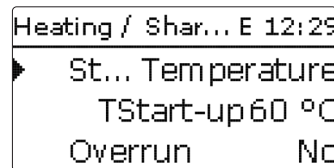

The **Start-up** option is used for switching on the loading pump with a delay to a demand. If the adjusted minimum temperature at the allocated sensor is exceeded or the adjusted start-up time has elapsed, the corresponding relay switches on.

The **Overrun** option is used for switching off the loading pump with a delay to a demand. If the temperature falls below the adjusted remaining boiler temperature or the adjusted overrun time has elapsed, the corresponding relay switches off.

**Valve**

Valves and parallel relays can use the shared relays **Valve 1** and **Valve 2**. These shared relays are energised individually or along with a reference relay (e. g. loading pump).



## 6.2 Heating circuits

The controller has 1 mixed and 1 unmixed weather-compensated heating circuit and is able to control up to 5 further mixed heating circuits by means of extension modules.

```
Heating / HCs   E 12:30
-----
HC 1
HC 2 static
▶ new HC...
```

If one or more extension modules are connected, they have to be registered with the controller. Only registered modules are available in the heating circuit selection (see page 59).

If **New HC...** is selected for the first time, the first heating circuit is allocated to the controller. The operating mode of the first heating circuit also applies to all further heating circuits, if they are linked.

In the heating circuit menu, relays for the heating circuit pump and the heating circuit mixer can be selected. Change the factory setting only if required.

```
HC 1           E 12:30
-----
▶ HC pump      R1
Mixer open     R2
Mixer closed   R3
```

3 free relays are required for a mixed heating circuit. If less than 3 free relays are available on the controller or module, a static (unmixed) heating circuit can be allocated.

If the measured flow temperature deviates from the set flow temperature, the mixer will be activated in order to adjust the flow temperature correspondingly.

The mixer runtime can be adjusted with the parameter **Interval**.

```
HC 1           E 12:30
-----
Interval       4 s
▶ Heat. sys.   Curve
Heating curve  1.0
```

The heating system **Constant** aims to keep the set flow temperature at a constant value which can be adjusted by means of the parameter **Set temperature**.

An outdoor temperature sensor cannot be allocated.

```
HC 1           E 12:31
-----
Heat. sys. Constant
▶ Set temp.    25 °C
Room therm.   >>
```

If the heating system **Curve** is selected, the controller calculates a set flow temperature by means of the outdoor temperature and the selected **heating curve**. In both cases, the dial setting of the remote control and the controller day correction or night correction are added.

### Heating system Constant:

Set flow temperature = set temperature + remote control + day correction or night correction

### Heating system Curve:

Set flow temperature = heating curve temperature + remote control + day correction or night correction.

The Remote control allows manual adjustment of the heating curve ( $\pm 15$  K). Furthermore, the heating circuit can be switched off or a rapid heating can be carried out by means of the remote control.

Heating circuit switched off means that the heating circuit pump is switched off and the mixer closed. The flow temperature is boosted to maximum for rapid heating when the remote control is set to rapid heating.

The calculated set flow temperature is limited by the adjusted values of the parameters **set flow temperature** and **minimum flow temperature**.

Maximum flow temperature  $\geq$  set flow temperature  $\geq$  minimum flow temperature

HC 1	E 12:31
Tflowmin	20 °C
Tflowmax	50 °C
<input type="checkbox"/> Pump off	

The parameter **Pump off** is used for switching off the heating circuit pump, if the adjusted value of the maximum flow temperature is exceeded by 5 K.

If the outdoor temperature sensor is defective, an error message will be indicated.

For the duration of this condition, the maximum flow temperature -5 K is assumed as the set flow temperature.

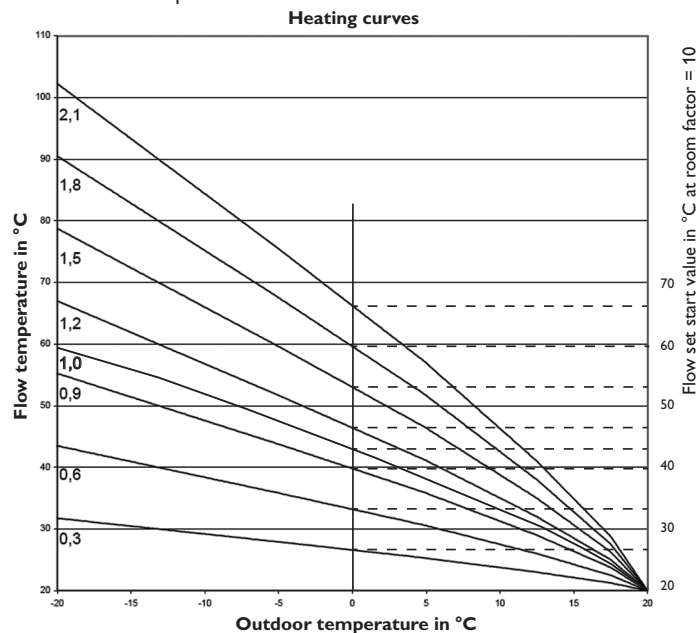

Flow set start value in °C at room factor = 10

## Room influence

If the heating system **Constant** is selected, the **Room influence** option will be available. The weather-compensated set flow temperature will thus be expanded by a demand-based room control.

HC 1	E 12:32
Heating curve	1.0
<input checked="" type="checkbox"/> Room influence	
Room factor	5

The parameter **Room factor** can be used for determining the intensity of the room influence.

### Room factor < 10

If the room factor is < 10, the controller will calculate the set flow temperature using the heating system Curve plus the room influence:

Set flow temperature = set temperature + remote control + day correction or night correction + room influence.

### Room factor = 10

If the room factor is equal to 10, the controller will calculate the set flow temperature by means of the room influence, the outdoor temperature will not be taken into account.

An outdoor temperature sensor cannot be allocated. The parameters **Day/Night correction, Timer** and **TSummer** will not be indicated.

The start value of the set flow temperature can be influenced by the parameter **Heating curve**. The start value corresponds to the set flow value of the selected curve at an outdoor temperature of 0°C.

Set flow temperature = set flow start value + room influence

HC 1	E 12:34
Room factor	10
Room therm.	➔➔
Sensor Flow	S1

In order to calculate the deviation of the room temperature from the adjusted set value, a room thermostat is required. The adjustments can be made using the parameter **RTH(1 ... 5)**. RTH1 is always pre-adjusted for the room influence with a room factor < 10.

## Room control

For the **Room control** with room factor = 10, the adjustment of all room thermostats activated will be considered. The controller will calculate the average value of the deviations measured.

## Room thermostat option

In order to integrate room thermostats into the control logic without activating the room influence option, proceed as follows:

Room thermos... E 12:18	
<input type="checkbox"/>	Room therm. 1
<input type="checkbox"/>	Room therm. 2
<input checked="" type="checkbox"/>	Room therm. 3

With the **Room thermostat** option, up to 5 room thermostats can be integrated into the control logic.

To each room thermostat, a sensor input can be allocated. The temperature at the allocated sensor is monitored. If the measured temperature exceeds the adjusted value **TambSet** at all activated room thermostats and if the parameter **HC off** is activated, the heating circuit will switch off.

Common room thermostats with potential-free outputs can be used alternatively. In this case, **Switch** must be selected in the **Type** channel. The corresponding input must beforehand be set to Switch in the Inputs/Outputs menu. Only inputs set to Switch will be displayed in the channel **Sen. RTH** as possible inputs for a Switch type room thermostat.

Room thermos... E 12:34	
Type	Sensor
<input checked="" type="checkbox"/> RTH sen.	S5
TambSet	18 °C

When the **Timer** option is activated, a timer is indicated in which time frames for the function can be adjusted. During these time frames, the adjusted room temperature decreases by the **Correction** value.



### Note:

For information on timer adjustment see page 11.

Room thermos... E 12:37	
<input type="checkbox"/>	Timer
Correction	5 K
<input checked="" type="checkbox"/> Relay	M1-R1

To each room thermostat, an additional relay can be allocated. The relay will switch on when the temperature falls below the adjusted room temperature. This way, the room in question can be excluded from the heating circuit via a valve as long as the desired room temperature is reached.

Room thermos... E 12:38	
Relay	M1-R1
<input checked="" type="checkbox"/> RTH	Activated
<input checked="" type="checkbox"/> HC off	

With the parameter **RTH**, the room thermostat can be temporarily deactivated or re-activated respectively. All adjustments remain stored.

## Correction timer

With the **Timer**, the day/night operation can be adjusted. During day phases, the set flow temperature is increased by the adjusted **Day correction** value, during night phases it is decreased by the **Night correction** value (night setback).

HC 2 static E 12:39	
Day correction	0 K
Night corr.	-5 K
<input checked="" type="checkbox"/> Timer	

HC 2 static E 12:40	
<input checked="" type="checkbox"/> Timer	
<input checked="" type="checkbox"/> Mode Day / night	
Timer HC	>>

The parameter **Mode** is used for selecting between the following correction modes:

**Day/night:** A reduced set flow temperature (night correction) is used during night operation.

**Day/off:** The heating circuit and the optionally activated backup heating are switched off during night operation.

**Room/off:** The heating circuit and the backup heating are switched off during night operation. If the temperature falls below the adjusted limit temperature at the allocated room sensor, the controller changes to the reduced heating mode.

**Outdoor/off:** The heating circuit and the backup heating are switched off during night operation. If the temperature falls below the adjusted limit temperature at the allocated outdoor temperature sensor, the controller changes to the reduced heating mode.

The **Timer HC** parameter can be used for adjusting the time frames for day operation.

### Summer mode

HC 2 static	E 12:40
▶ TSummer	20 °C
Daytime on	00:00
Daytime off	00:00

The automatic summer mode becomes active when the outdoor temperature exceeds the adjusted summer temperature **TSummer**. This can be limited to a daytime frame with the parameters **Daytime on** and **Daytime off**. Outside the adjusted time frame, the lower temperature **TNight** is used in summer mode. In summer mode, the heating circuit is switched off.

HC 2 static	E 12:40
Daytime on	09:00
Daytime off	19:00
▶ TNight	14 °C

### Backup heating

HC 2 static	E 12:41
<input checked="" type="checkbox"/> Afterheating	
▶ Afterheating	➡➡
<input type="checkbox"/> DHW priority	

For heating circuit **backup heating**, the calculated set flow temperature is compared with the temperature at one or two store/buffer reference sensors (differential control). If this temperature difference ( $\Delta T_{on}$ ) is too small, backup heating will be activated. It will be switched off, if the difference ( $\Delta T_{off}$ ) between the store and the set flow temperature is large enough.

If **Thermostat** is selected, the set flow temperature is compared with a store reference sensor. If **Zone** is selected, the set flow temperature is compared with 2 reference sensors. The switching conditions have to be fulfilled at both reference sensors.

Afterheating	E 12:41
$\Delta T_{on}$	3.0 K
$\Delta T_{off}$	5.0 K
▶ $\Delta T_{flow}$	0.0 K

In the **Set temperature** mode, backup heating will heat to the set flow temperature without a reference sensor. The value  $\Delta T_{flow}$  will be automatically added to the set boiler temperature in order to compensate for e. g. the heat loss in the pipes. This can be used with modulating boilers which provide direct backup heating without a store.

Afterheating	E 12:41
▶ Mode	Zone
Sensor 1	S3
Sensor 2	S4

Separate relays can be allocated to a demand and to a boiler loading pump (free relays or shared relays / demand 1, 2 or pump 1, 2 respectively). If **shared relays** are used and have been adjusted and allocated, the parameters **Boiler protection**, **Demand**, **Overrun** become active, provided they have previously been adjusted.

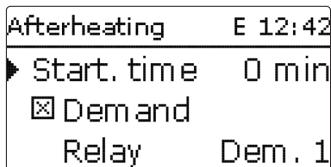

If the Correction mode **Day/Off**, **Room/Off** or **Outdoor/Off** is selected, the heating circuits and the backup heating are completely switched off during night operation. If the system has a store, the **Starting time** can be used for activating the backup heating before the day operation in order to heat the store to a sufficiently high temperature.

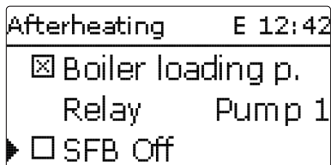

If **SFB Off** is activated, backup heating will be suppressed as long as a solid fuel boiler is switched on, which has previously been activated in the **Arrangement/Optional functions** menu.

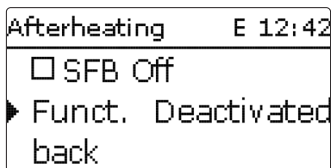

At first, backup heating is activated and can be temporarily deactivated.

### DHW priority

If the parameter **DHW priority** is activated, the heating circuit will be switched off and the backup heating be suppressed as long as DHW heating takes place, which has previously been activated in the **Heating/Optional functions** menu.

### Remote access

With the parameter **Remote access** different types of remote access to the controller can be activated.

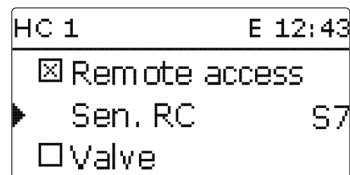

In the sensor selection menu, only outputs which have previously been selected as the input for remote access in the **Inputs/Outputs** menu will be available.

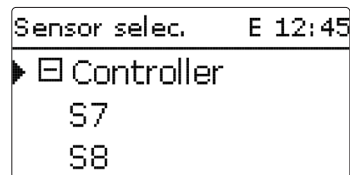

The following types of remote access are possible:

**Remote control:** A device which allows manual adjustment of the heating curve, thus influencing the set flow temperature.

→ In order to use a remote control, set the corresponding input to **Remote control**.

**Room control unit:** A device incorporating a remote control as well as an additional operating mode switch.

→ In order to use a room control unit, set the corresponding input to **OMS**.

The operating mode switch of the room control unit is used for adjusting the operating mode of the controller. If a room control unit is used, the operating mode can be adjusted by means of the room control unit only. The controller menu only allows the activation of the operating mode **Holiday**.

**Remote access with the app:** In addition to the wireline possibilities of remote access, an app can be used as well.

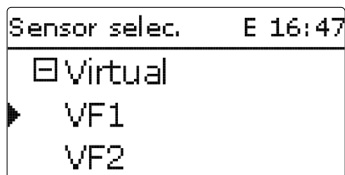

→ In order to use an app, adjust the corresponding input to **VF1**.

If you use an app, the operating mode can be adjusted in the controller menu as well as in the app.

### Valve option

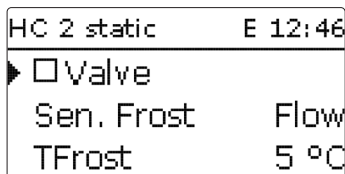

The **Valve** option can be used for allocating a relay which switches in parallel to the heating circuit (free relays or shared relays /valve 1, 2).

### Antifreeze function

The antifreeze function of the heating circuit can be used to temporarily activate an inactive heating circuit during sudden temperature drop in order to protect it against frost damage.

The temperature at the allocated antifreeze sensor **Sen. Frost** is monitored. If the temperature falls below the adjusted antifreeze temperature **TFrost**, the heating circuit will be activated until the antifreeze temperature is exceeded by 2K, but at least for 30 min.

### Chimney sweeper function

The chimney sweeper function can be used for enabling a quick access to measurement conditions without menu operation for the chimney sweeper.

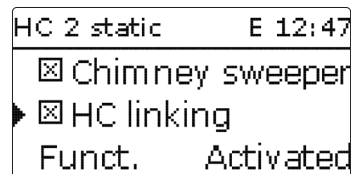

The chimney sweeper function is activated in all heating circuits by default. The chimney sweeper mode can be activated by pressing button **6** for 5 s

In the chimney sweeper mode, the heating circuit mixer opens, the heating circuit pump and the backup heating contact are activated. While the chimney sweeper mode is active, the directional pad is flashing red. Additionally, **Chimney sweeper** and a countdown of 30 min are indicated on the display.

When the countdown has elapsed, the chimney sweeper mode is automatically deactivated. If, during the countdown, button **6** is again pressed for more than 5 s, the chimney sweeper mode will stop.

Beginning with the second heating circuit, all heating circuits offer the parameter **HC linking**. Using this parameter, the heating circuits adopt the operating mode of the first heating circuit. If you wish to adjust the operating mode of the heating circuits separately, deactivate the linking option.

## Heating/Heating circuits/new HC... / Internal or Module 1...5

Adjustment channel	Description	Adjustment range/selection	Factory setting
HC pump	Heating circuit pump	system dependent	system dependent
Mixer open	Relay selection mixer open	system dependent	system dependent
Mixer closed	Relay selection mixer closed	system dependent	system dependent
Interval	Mixer interval	1...20s	4 s
Heat. sys.	Heating system selection	Curve, Constant	PWM characteristic curve
Heating curve	Heating curve	0.3...3.0	1.0
Set temp.	Set temperature	10...100 °C	25 °C
Room influence	Room influence option	Yes, No	No
Room factor	Room influence factor	1...10	5
Room therm.	Room thermostats sub-menu	-	-
Room therm. 1...5	Room thermostat option (1...5)	Yes, No	No
Type	Room thermostat type selection	Sensor, Switch	Sensor
RTH sen.	RTH input allocation	system dependent	system dependent
TambSet	Room temperature	10...30 °C	18 °C
Hysteresis	RTH hysteresis	0.5...20.0 K	0.5 K
Timer	RTH timer	Yes, No	No
Correction	Correction	1...20K	3K
Relay	RTH relay selection	system dependent	system dependent
RTH	Room thermostat	Activated, Deactivated	Activated
HC off	Heating circuit off option	Yes, No	No
Sensor Flow	Flow sensor selection	system dependent	system dependent
Tflowmin	Minimum flow temperature	20...89 °C	20 °C
Tflowmax	Maximum flow temperature	21...90 °C	50 °C
Pump off	Deactivation of the heating circuit pump when Tflowmax is exceeded	Yes, No	No
Sen. Outd.	Outdoor sensor selection	system dependent	S2
Day correction	Day correction	-5...+45 K	0 K
Night corr.	Night correction	-20...+30K	-5K
Timer	Timer option	Yes, No	No
Mode	Correction mode selection	Day/night, Day/Off, Room/Off, Outdoor/Off	Day/night
Sen. Room	Room sensor	system dependent	system dependent
TLimit	Limit temperature	-20...+30 °C	16 °C/0 °C

Adjustment channel	Description	Adjustment range/selection	Factory setting
Timer HC	Heating circuit timer	Yes, No	No
TSummer	Summer temperature day	0...40 °C	20 °C
Daytime on	Daytime on	00:00...23:45	00:00
Daytime off	Daytime off	00:00...23:45	00:00
TNight	Summer temperature night	0...40 °C	14 °C
Afterheating	Backup heating option	Yes, No	No
Mode	Backup heating mode selection	Therm., Zone, Set temp.	Therm.
Sensor 1	Reference sensor 1	system dependent	system dependent
Sensor 2	Reference sensor 2 (if mode = Zone)	system dependent	system dependent
ΔTon	Switch-on temperature difference	-15.0...44.5 K	3 K
ΔToff	Switch-off temperature difference	-14.5...45.0K	5K
ΔTFlow	Increase for the set flow temperature	0...20 K	0 K
Start. time	Backup heating starting time	0...120 min	0 min
Demand	Demand option	Yes, No	No
Relay	Relay selection	system dependent	system dependent
Boiler loading p.	Boiler loading pump option	Yes, No	No
Relay	Relay selection	system dependent	system dependent
SFB Off	Solid fuel boiler off option	Yes, No	No
Funct.	De/activation of the backup heating	Activated, Deactivated	Activated
DHW priority	DHW priority option	Yes, No	No
Remote access	Remote access option	Yes, No	No
Sen. RC	Remote access input selection	system dependent	system dependent
Valve	Option valve in parallel to the heating circuit	Yes, No	No
Relay	Relay selection (valve)	system dependent	system dependent
Sen. Frost	Antifreeze sensor	Flow, Outdoor	Flow
TFrost	Antifreeze temperature	+4...+10 °C/ -20...+10 °C	+5 °C/0 °C
Chimney sweeper	Chimney sweeper option	Yes, No	Yes
Linking	Linking option Operating mode (HC2...7)	Yes, No	Yes
Funct.	De/activation of the heating circuit	Activated/Deactivated	Activated

## Screed drying

This function is used for time- and temperature-controlled screed drying in selectable heating circuits.

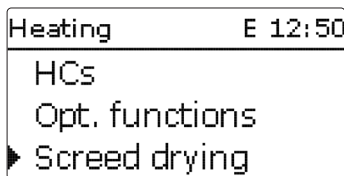

### Note:

The screed drying function is blocked against the chimney sweeper function. In order to activate the screed drying function, the chimney sweeper function must be deactivated in all heating circuits.

The heating circuits can be selected in the **Heating/Screed drying** menu. At the end of this menu, the function can be set to standby by using the "Activated" item.

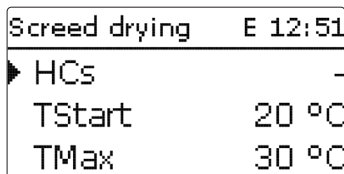

If the button  is pressed and held down for at least 5 s, the screed drying programme will start.

The message **Screed drying** will be indicated on the display and the remaining time will be indicated as a countdown (dd:hh). During this process, the directional pad is flashing green.

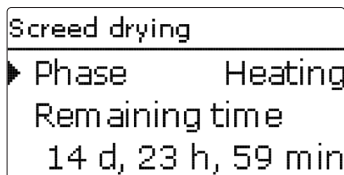

If button  is pressed again and held down for at least 5 s, the screed drying programme will be cancelled. For this reason, a security enquiry appears. If you wish to interrupt the screed drying function, confirm the security enquiry.

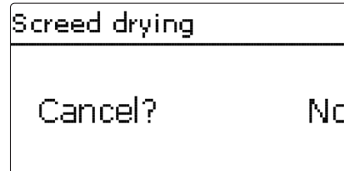

At the beginning of the screed drying function, the heating circuits selected are put into operation for the adjusted **Rise time** with the start temperature as the set flow temperature. Afterwards, the set flow temperature increases in steps by the adjustable rise value for the duration of the adjustable rise time until the holding temperature is reached. After the holding time has elapsed, the set flow temperature is reduced in steps until the start temperature is reached again.

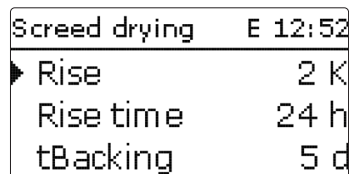

If the set flow temperature is not reached within 24 hours or after the rise time respectively, or if it is constantly exceeded, the screed drying function will be cancelled.

The heating circuit switches off and an error message is displayed. The directional pad flashes red.

Error 1: flow sensor defective

Error 2: the flow temperature is higher than the maximum flow temperature + 5 K for over 5 min

Error 3: the flow temperature is higher than the holding temperature + rise value for over 30 min

Error 4: the flow temperature is higher than the set flow temperature + rise value for over 2 h

Error 5: the flow temperature is lower than the set flow temperature - rise value for over a rise time period

During screed drying of the heating circuits selected, the other heating circuits run corresponding to their operating modes.

Button  can be used any time for changing to the status or main menu of the controller in order to carry out adjustments.



When the screed drying function has been successfully completed, the corresponding heating circuits change to their operating modes selected.

Screed drying will automatically be deactivated. The chimney sweeper function will be activated in all heating circuits.



**Note:**

Make sure the heating circuits are supplied with heat from a heat source (backup heating).



**Note:**

If an SD card has been inserted into the slot, a screed protocol will be generated.

### Heating/Screed drying

Adjustment channel	Description	Adjustment range/ selection	Factory setting
HCs	Heating circuit selection	HC1 ... 7	system dependent
TStart	Start temperature	10 ... 30 °C	20 °C
TMax	Holding temperature	20 ... 60 °C	30 °C
Rise	Rise	1 ... 10 K	2 K
Rise time	Rise time	1 ... 24 h	24 h
tBacking	Tmax holding time	1 ... 20 d	5 d
Funct.	Activation/Deactivation	Activated/Deactivated	Deactivated

### 6.3 Optional functions

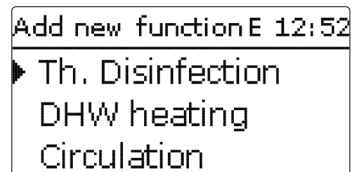

In this menu, optional functions can be selected and adjusted for the heating part of the arrangement.

By selecting **Add new function**, different pre-programmed functions can be selected. The optional functions are available as long as free relays are available.

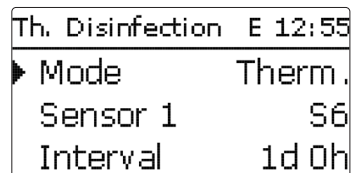

When a function is selected, a sub-menu opens in which all adjustments required can be made.

In this sub-menu, a circulating pump relay can be allocated to the function. A relay switching in parallel to the corresponding pump can be selected in the **Valve** menu.

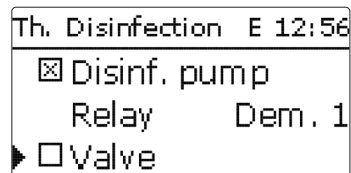

All optional functions of the heating contain the menu items **Demand** and **Boiler loading pump** which can be used for controlling a heat generator for backup heating.

They can be activated separately or in common.

In the **Demand** menu, a backup heating demand relay can be allocated to the function. All free relays are available for selection.

A shared relay **Demand 1/2** can also be selected in this menu (see page 30).

In the **Boiler loading pump** menu, a loading pump can be allocated to the backup heating. Not only is it possible to directly allocate a relay, it is also possible to select a shared relay **Pump 1/2**. When selecting shared relays, further options such as the boiler protection, start-up or overrun function are available (see page 30).

If the parameter **SFB Off** is activated, backup heating will be suppressed as long as a solid fuel boiler is switched on, which has previously been activated in the **Arrangement/Optional functions** menu.

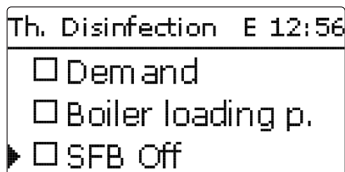

When a function has been selected and adjusted, it will appear in the **Opt. functions** menu above the menu item **Add new function**.

This allows an easy overview of functions already activated.

An overview about which sensor has been allocated to which component and which relay has been allocated to which function is given in the **Status/Service** menu.

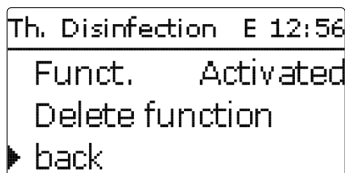

At the end of each optional function sub-menu, the menu items **Function** and **Delete function** are available.

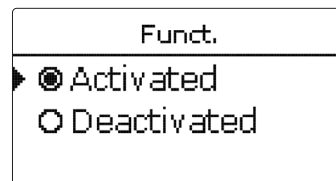

With the menu item **Function**, an optional function already selected can be temporarily deactivated or re-activated respectively. All adjustments remain stored, the allocated relays remain occupied and cannot be allocated to another function.

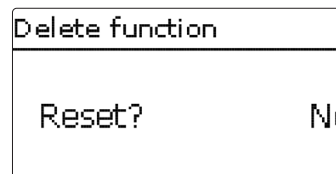

If the menu item **Delete function** is confirmed by pressing button **5**, a security enquiry appears. The setting can be changed between **Yes** and **No** by pressing buttons **2** and **4**. If **Yes** has been selected and confirmed by pressing button **5**, the function is deleted and the corresponding available again.

## DHW heating

DHW heating		E 12:57
▶ Sensor 1		S7
Ton		40 °C
Toff		45 °C

The DHW heating is used for demanding a backup heating for heating the DHW store.

Mode	
<input type="radio"/> Zone	
▶ <input checked="" type="radio"/> Therm.	

For the DHW heating, 2 different modes are available:

### Thermal mode

The allocated demand relay is switched on when the temperature at the allocated sensor 1 falls below the adjusted switch-on temperature. If the temperature at the allocated sensor exceeds the adjusted switch-off temperature, the relay is switched off.

### Zone mode

If the Zone mode is selected, the switch-on and switch-off conditions must be fulfilled at 2 sensors for the relay to switch on or off respectively.

DHW heating		E 12:58
▶ <input type="checkbox"/> Timer		
<input checked="" type="checkbox"/> DHW loading p...		
Relay		Dem. 1

When the **Timer** option is activated, a timer is indicated in which time frames for the function can be adjusted.



### Note:

For information on timer adjustment see page 11.

## Heating/Opt. functions/Add new function/DHW heating

Adjustment channel	Description	Adjustment range/selection	Factory setting
DHW heating	DHW heating	system dependent	system dependent
Mode	Mode	Therm., Zone	Therm.
Sensor 1	Reference sensor 1	system dependent	system dependent
Sensor 2	Reference sensor 2 (if mode = Zone)	system dependent	system dependent
Ton	Switch-on temperature	0 ... 94 °C	40 °C
Toff	Switch-off temperature	1 ... 95 °C	45 °C
Timer	Timer option	Yes, No	No
DHW loading p...	DHW loading pump option	Yes, No	Yes
Relay	Relay selection DHW loading pump	system dependent	system dependent
Valve	Valve option	Yes, No	No
Relay	Relay selection	system dependent	system dependent
Demand	Demand option	Yes, No	No
Relay	Relay selection	system dependent	system dependent
Boiler loading p.	Boiler loading pump option	Yes, No	No
Relay	Loading pump relay selection	system dependent	system dependent
SFB Off	Solid fuel boiler off option	Yes, No	No
Funct.	Activation/Deactivation	Activated/Deactivated	Activated

## Thermal disinfection

This function helps to contain the spread of Legionella in DHW stores by systematically activating the backup heating.

One or two sensors can be selected for this function.

For thermal disinfection, the temperature at the allocated sensor has to be monitored. Protection is ensured when, during the monitoring period, the disinfection temperature is continuously exceeded for the entire disinfection period.

The monitoring period starts as soon as the temperature at the allocated sensor falls below the disinfection temperature. When the monitoring period ends, the allocated reference relay activates the backup heating. The disinfection period starts, if the temperature at the allocated sensor exceeds the disinfection temperature.

Thermal disinfection can only be completed when the disinfection temperature is exceeded for the duration of the disinfection period without any interruption.

If the Zone mode is selected, the switch-on and switch-off conditions must be fulfilled at 2 sensors for the relay to switch on or off respectively.

Th. Disinfection E 12:59	
Interval	1d 0h
Temperature	60 °C
▶ Duration	1.0 h

### Starting time delay

If the starting delay option is activated, a starting time for the thermal disinfection with starting delay can be adjusted. The activation of the backup heating is then delayed until that starting time after the monitoring period has ended.

If the monitoring period ends, for example, at 12:00 o'clock, and the starting time has been set to 18:00, the reference relay will be energised with a delay of 6 hours at 18:00 instead of 12:00 o'clock.

Th. Disinfection E 12:59	
▶ <input checked="" type="checkbox"/> Start. time	
Start. time	20:00
Hyst. off	5 K

## Heating/Opt. functions/Add new function/Th. disinfection

Adjustment channel	Description	Adjustment range/ selection	Factory setting
Mode	Mode selection	Therm., Zone	Therm.
Sensor 1	Reference sensor 1 selection	system dependent	system dependent
Sensor 2	Reference sensor 2 selection (if mode = Zone)	system dependent	system dependent
Interval	Monitoring period	0 ... 30, 1 ... 23 (dd:hh)	1d 0h
Temperature	Disinfection temperature	45 ... 90 °C	60 °C
Duration	Disinfection period	0.5 ... 24.0 h	1.0 h
Start. time	Starting delay option	Yes, No	No
Start. time	Starting time	00:00 ... 23:30	20:00
Hyst. on	Switch-on hysteresis	2 ... 20 K	5 K
Hyst. off	Switch-off hysteresis	1 ... 19 K	2 K
Disinf. pump	Disinfection pump option	Yes, No	Yes
Relay	Disinfection pump relay	system dependent	system dependent
Valve	Valve option	Yes, No	No
Relay	Relay Valve	system dependent	system dependent
Demand	Demand relay selection	Yes, No	No
Relay	Relay Demand	system dependent	system dependent
Boiler loading p.	Option boiler loading pump	Yes, No	No
Relay	Relay selection Boiler loading pump	system dependent	system dependent
SFB Off	Solid fuel boiler off option	Yes, No	No
Func.	Activation / Deactivation	Activated / Deactivated	Activated

## Circulation

Circulation	E 12:59
▶ Mode	Thermal
Sensor	S7
Ton	40 °C

The **Circulation** function can be used for controlling a circulation pump. For the control logic, 5 different modes are available:

- Demand
- Thermal
- Timer
- Demand + Timer
- Thermal + Timer

If one of the variants is selected, the corresponding adjustment channels will appear.

### Demand

The switch-on condition is fulfilled, if a demand is being activated for the adjusted switch-on delay (contact closed). The switch-on condition is then met for the adjusted (minimum) runtime. The condition will then be ignored for the adjusted break time, the circulation will be in the break status.

### Thermal

The temperature at the allocated sensor is monitored. The allocated relay switches on when the temperature falls below the adjusted switch-on temperature. If the temperature exceeds the switch-off temperature, the relay switches off.

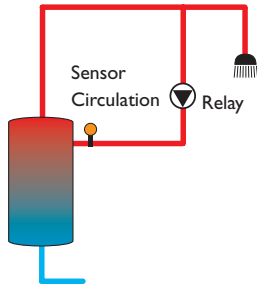

## Timer

The relay is switched on during the adjusted time frames, outside of them it switches off. For information on how to adjust the timer, see below.

### Demand + Timer

The relay operates when the switch-on conditions of both above mentioned variants are fulfilled.

### Thermal + Timer

The relay operates when the switch-on conditions of both above mentioned variants are fulfilled.

Mode
<input type="radio"/> Therm. + Timer
<input type="radio"/> Timer
▶ <input checked="" type="radio"/> Thermal



### Note:

If the flow switch is connected to the input S1 ... S8, continuity must be detected for at least 5 s for the controller to react, 1s if the flow switch is connected to an impulse input (S9).

Circulation	E 13:00
▶ Timer	»»
<input checked="" type="checkbox"/> Circ. pump	
Relay	Dem. 1

When the **Timer**, **Demand + Timer** or **Therm. + Timer** variant is activated, a timer is indicated in which time frames for the function can be adjusted.



### Note:

For information on timer adjustment see page 11.

## Heating/Opt. functions/Add new function/Circulation

Adjustment channel	Description	Adjustment range/ selection	Factory setting
Mode	Variant	Demand,Thermal,Timer, Demand+Timer,Therm.+Timer	Thermal
Sensor	Circulation sensor selection	system dependent	system dependent
Ton	Switch-on temperature	10 ... 59 °C	40 °C
Toff	Switch-off temperature	11 ... 60 °C	45 °C
Delay	Demand switch-on delay	0 ... 3 s	0 s
Runtime	Runtime	01:00 ... 15:00 min	03:00 min
Break time	Break time	10 ... 60 min	30 min
Timer	Timer option	Yes, No	No
Circ. pump	Circulation pump option	Yes, No	Yes
Relay	Relay selection	system dependent	system dependent
Valve	Valve option	Yes, No	No
Relay	Relay selection	system dependent	system dependent
Demand	Demand option	Yes, No	No
Relay	Relay selection	system dependent	system dependent
Boiler loading p.	Boiler loading pump option	Yes, No	No
Relay	Relay selection	system dependent	system dependent
SFB Off	Solid fuel boiler off option	Yes, No	No
Funct.	Activation/Deactivation	Activated/Deactivated	Activated

## 7 Arrangement

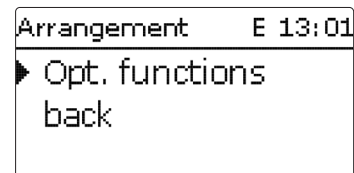

In this menu, all adjustments for the non-heating part of the arrangement can be made.

A range of optional functions can be selected and adjusted.

### 7.1 Optional functions

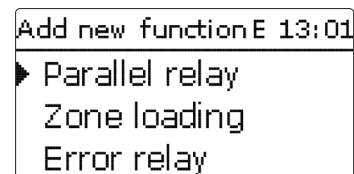

In this menu, additional functions can be selected and adjusted for the arrangement.

By selecting **Add new function**, different pre-programmed functions can be selected. The optional functions are available as long as free relays are available.

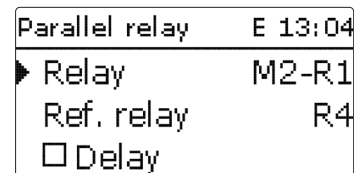

When a function is selected, a sub-menu opens in which all adjustments required can be made.

With this sub-menu, a relay and, if necessary, certain system components can be allocated to the function.

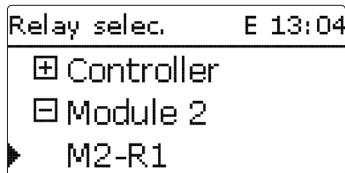

The menu item **Relay selec.** is available in all optional functions. Therefore, it will not be explained in the individual function descriptions.

With this menu item, a relay can be allocated to the function. All free relays are available for selection.

In the sub-menu **Controller**, all free relays of the controller are displayed. If external modules are connected and registered, their relays will be displayed in corresponding sub-menus.

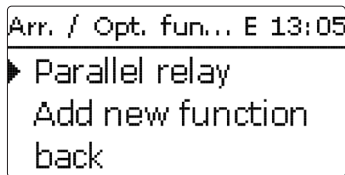

When a function has been selected and adjusted, it will appear in the **Opt. functions** menu above the menu item **Add new function**.

This allows an easy overview of functions already activated.

An overview about which sensor has been allocated to which component and which relay has been allocated to which function is given in the **Status/Meas./Balance values** menu.

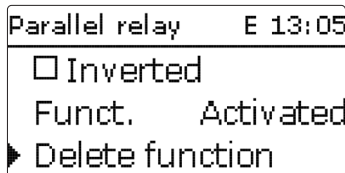

At the end of each optional function sub-menu, the menu items **Function** and **Delete function** are available.

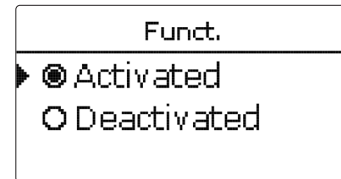

With the menu item **Function**, an optional function already selected can be temporarily deactivated or re-activated respectively. All adjustments remain stored, the allocated relays remain occupied and cannot be allocated to another function.

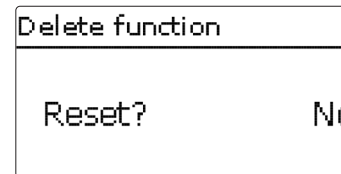

If the menu item **Delete function** is confirmed by pressing button **5**, a security enquiry appears. The setting can be changed between **Yes** and **No** by pressing buttons **2** and **4**. If **Yes** has been selected and confirmed by pressing button **5**, the function is deleted and available under **Add new function** again. The corresponding relays are available again.

## Parallel relay

Parallel relay	E 13:04
▶ Relay	M2-R1
Ref. relay	R4
<input type="checkbox"/> Delay	

### Arrangement/Opt. functions/Add new function/Parallel relay

Adjustment channel	Description	Adjustment range/selection	Factory setting
Relay	Relay selection	system dependent	system dependent
Ref. relay	Reference relay selection	system dependent	system dependent
Delay	Delay option	Yes, No	No
Duration	Delay time	1 ... 30 min	1 min
Overrun	Overrun option	Yes, No	No
Duration	Overrun time	1 ... 30 min	1 min
Inverted	Inverted switching option	Yes, No	No
Funct.	Activation/Deactivation	Activated/Deactivated	Activated



#### Note:

If a relay is in the manual mode, the selected parallel relay will not be energised.

The **Parallel relay** function can be used for operating an allocated parallel relay alongside a selected reference relay. With this function, e. g. a valve can be controlled in parallel to the pump via a separate relay.

If the **Overrun** option is activated, the parallel relay remains switched on for the adjusted **overrun time** after the reference relay has been switched off.

If the **Delay** option is activated, the parallel relay will be energised after the adjusted delay time has elapsed. If the reference relay is switched off again during the delay time, the parallel relay will not be switched on at all.

If the **Inverted** option is activated, the parallel relay switches on when the reference relay switches off and vice versa.

## Mixer

Mixer	E 13:06
▶ Relay closed	M2-R2
Relay open	M2-R1
Sensor	M2-S1

### Arrangement/Opt. functions/Add new function/Mixer

Adjustment channel	Description	Adjustment range/selection	Factory setting
Relay closed	Relay selection mixer closed	system dependent	system dependent
Relay open	Relay selection mixer open	system dependent	system dependent
Sensor	Sensor selection	system dependent	system dependent
TMixer	Mixer target temperature	0 ... 130 °C	60 °C
Interval	Mixer interval	1 ... 20 s	4 s
Funct.	Activation/Deactivation	Activated/Deactivated	Activated

The **Mixer** function can be used to adjust the actual flow temperature to the desired **mixer target temperature**. The mixer is opened or closed in pulses depending on this deviation. The pulses are determined by the adjustable **Interval**. The pause is determined by the difference between the actual value and the set value.

Mixer	E 13:06
▶ TMixer	60 °C
Interval	4 s
Funct.	Activated



## Zone loading

Zone loading	E 13:06
▶ Relay	M2-R4
Sensor top	M2-S1
Sensor base	M2-S2

The **Zone loading** function can be used for loading a store zone between 2 sensors (sensor top and sensor base).

For monitoring the switch-on and switch-off conditions, 2 sensors are used. The switch-on and switch-off temperatures **Ton** and **Toff** are used as reference parameters.

If the measured temperatures at both allocated sensors fall below the adjusted switching threshold **Ton**, the relay is energised. It is switched off again when the temperature at both sensors has exceeded **Toff**.

If one of the two sensors is defective, zone loading is suppressed or switched off.

Zone loading	E 13:07
Ton	45 °C
Toff	60 °C
▶ <input type="checkbox"/> Timer	

When the **Timer** option is activated, a timer is indicated in which time frames for the function can be adjusted.



### Note:

For information on timer adjustment see page 11.

## Arrangement / Opt. functions / Add new function / Zone loading

Adjustment channel	Description	Adjustment range / selection	Factory setting
Relay	Relay selection	system dependent	system dependent
Sensor top	Top sensor selection	system dependent	system dependent
Sensor base	Base sensor selection	system dependent	system dependent
Ton	Boiler switch-on temperature	0 ... 94 °C	45 °C
Toff	Boiler switch-off temperature	1 ... 95 °C	60 °C
Timer	Timer option	Yes, No	No
Funct.	Activation / Deactivation	Activated / Deactivated	Activated

## Heat exchange

Heat exchange	E 13:07
▶ Relay	M2-R5
Sen. Source	S8
Sen. Sink	M2-S6

### Arrangement / Opt. functions / Add new function / Heat exchange

Adjustment channel	Description	Adjustment range / selection	Factory setting
Relay	Relay selection	system dependent	system dependent
Sen. Source	Heat source sensor selection	system dependent	system dependent
Sen. Sink	Heat sink sensor selection	system dependent	system dependent
$\Delta T_{on}$	Switch-on temperature difference	1.0 ... 30.0 K	6.0 K
$\Delta T_{off}$	Switch-off temperature difference	0.5 ... 29.5 K	4.0 K
$\Delta T_{set}$	Set temperature difference	1.5 ... 40.0 K	10.0 K
Rise	Rise	1.0 ... 20.0 K	2.0 K
Min speed	Minimum speed	20 ... 100%	100%
Tmax	Maximum temperature of the store to be loaded	10 ... 95 °C	60 °C
Tmin	Minimum temperature of the store to be loaded	10 ... 95 °C	10 °C
Timer	Timer option	Yes, No	No
Funct.	Activation / Deactivation	Activated / Deactivated	Activated

The **Heat exchange** function can be used for transferring heat from a heat source to a heat sink.

The allocated relay is energised when all switch-on conditions are fulfilled:

- the temperature difference between the allocated sensors has exceeded the switch-on temperature difference
  - the temperature difference between the allocated sensors has not fallen below the switch-off temperature difference
  - the temperature at the heat source sensor has exceeded the minimum temperature
  - the temperature at the heat sink sensor has fallen below the maximum temperature
  - one of the adjusted time frames is active (if the **Timer** option is selected)
- Speed control is deactivated by default. In order to activate speed control, reduce the minimum pump speed.

When the **Set temperature difference** is exceeded, pump speed control starts. If the temperature difference increases by the adjustable Rise value, the pump speed increases by 10 % respectively.



#### Note:

For information on timer adjustment see page 11.

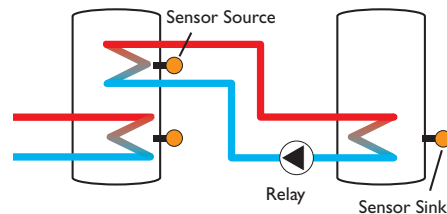

## Return preheating

Ret. preheat.	E 13:08
▶ Relay	M3-R1
Sen. HS	M3-S3
Sen. Return	M3-S2

### Arrangement / Opt. functions / Add new function / Ret. preheat.

Adjustment channel	Description	Adjustment range / selection	Factory setting
Relay	Relay selection	system dependent	system dependent
Sen. HS	Heat source sensor selection	system dependent	system dependent
Sen. Return	Return sensor selection	system dependent	system dependent
$\Delta T_{on}$	Switch-on temperature difference	2.0 ... 30.0 K	6.0 K
$\Delta T_{off}$	Switch-off temperature difference	1.0 ... 29.0 K	4.0 K
Summer off	Summer switch-off option	Yes, No	No
Sensor	Outdoor sensor selection	system dependent	system dependent
Toff	Switch-off temperature	10 ... 60 °C	20 °C
Funct.	Activation / Deactivation	Activated / Deactivated	Activated

The **Return preheating** function can be used for transferring heat from a heat source to the heating circuit return.

The allocated relay is energised when all switch-on conditions are fulfilled:

- the temperature difference between the allocated sensors has exceeded the switch-on temperature difference
- the temperature difference between the allocated sensors has not fallen below the switch-off temperature difference
- if **Summer off** is activated, the temperature at the outdoor temperature sensor falls below the adjusted outdoor temperature value
- the temperature at the allocated sensor does not exceed the switch-off temperature (if the **Summer off** option is selected)

Speed control is deactivated by default. In order to activate speed control, reduce the minimum pump speed.

With the summer switch-off option, the return preheating can be suppressed outside the heating period. If the heating circuit concerned is controlled by the controller, the adjustments automatically adapt to the heating circuit.

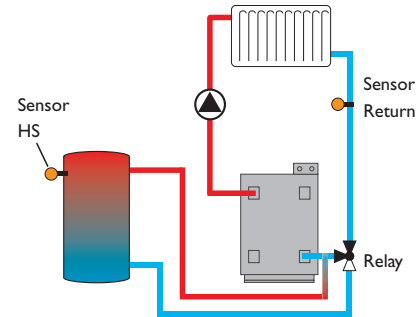

## Solid fuel boiler

Solid fuel boiler E 13:09	
▶ Relay	R4
Sen. Boiler	S7
Sen. Store	S8

### Arrangement / Opt. functions / Add new function / Solid fuel boiler

Adjustment channel	Description	Adjustment range / selection	Factory setting
Relay	Relay selection	system dependent	system dependent
Sen. Boiler	Solid fuel boiler sensor selection	system dependent	system dependent
Sen. Store	Store sensor selection	system dependent	system dependent
$\Delta T_{on}$	Switch-on temperature difference	2.0 ... 30.0 K	6.0 K
$\Delta T_{off}$	Switch-off temperature difference	1.0 ... 29.0 K	4.0 K
$\Delta T_{set}$	Set temperature difference	3.0 ... 40.0 K	10.0 K
Rise	Rise	1.0 ... 20.0 K	2.0 K
Min speed	Minimum speed	20 ... 100%	100%
Tmax st.	Maximum temperature	4 ... 95 °C	60 °C
Tmin boiler	Minimum temperature	4 ... 95 °C	60 °C
Funct.	Activation / Deactivation	Activated / Deactivated	Activated

The **Solid fuel boiler** function can be used for transferring heat from a solid fuel boiler to a store.

The allocated relay is energised when all switch-on conditions are fulfilled:

- the temperature difference between the allocated sensors has exceeded the switch-on temperature difference
- the temperature difference between the allocated sensors has not fallen below the switch-off temperature difference
- the temperature at the solid fuel boiler sensor has exceeded the minimum temperature
- the temperature at the store sensor has fallen below the maximum temperature
- one of the adjusted time frames is active (if the **Timer** option is selected)

Speed control is deactivated by default. In order to activate speed control, reduce the minimum pump speed.

When the **Set temperature difference** is exceeded, pump speed control starts. If the temperature difference increases by the adjustable Rise value, the pump speed increases by 10 % respectively.

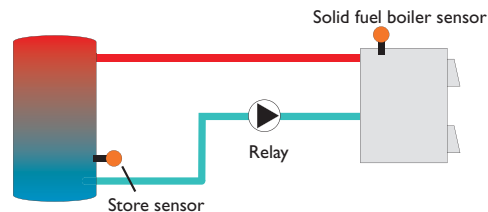

## Function block

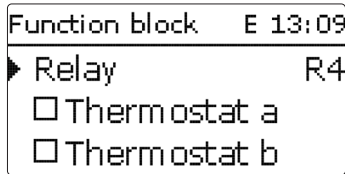

In addition to the pre-defined optional functions, function blocks consisting of thermostat functions, timer and differential functions are available. With the help of these function blocks, further components and functions respectively can be controlled.

To each function block, sensors and free relays can be allocated. Sensors already in use can be allocated again without impeding their control functions.

Within a function block the functions are interconnected (AND gate). This means that the conditions of all the activated functions have to be fulfilled for switching the allocated relay. As soon as one condition is not fulfilled, the relay is switched off.

### Thermostat function

The relay allocated to the function block is switched on, when the adjusted switch-on temperature ( $Th(x)_{on}$ ) is reached. It is switched off when the adjusted switch-off temperature ( $Th(x)_{off}$ ) is reached. The switching conditions of all other activated functions of the function block have to be fulfilled as well.

Allocate the reference sensor in the **Sensor** channel.

Adjust the maximum temperature limitation with  $Th(x)_{off} > Th(x)_{on}$  and the minimum temperature limitation with  $Th(x)_{on} > Th(x)_{off}$ . The temperatures cannot be set to an identical value.

### $\Delta T$ function

The relay allocated to the function block is switched on as soon as the adjusted switch-on temperature difference ( $\Delta Th(x)_{on}$ ) is reached. It is switched off as soon as the adjusted switch-off temperature difference ( $\Delta Th(x)_{off}$ ) is reached. The switching conditions of all other activated functions of the function block have to be fulfilled as well.

The  $\Delta T$  function is equipped with a speed control function. A set temperature difference and a minimum speed can be adjusted. The non-adjustable rise value is 2 K.

## Reference relay

Up to 5 reference relays can be selected.

Whether the reference relays are to be switched in series (AND) or in parallel (OR) can be adjusted in the **Mode** channel.

### OR mode

If at least one of the reference relays is active, the switch-on condition for the function block is considered fulfilled. The switching conditions of all other activated functions of the function block have to be fulfilled as well.

### AND mode

If all reference relays are active, the switch-on condition for the function block is considered fulfilled. The switching conditions of all other activated functions of the function block have to be fulfilled as well.



### Note:

For information on timer adjustment see page 11.

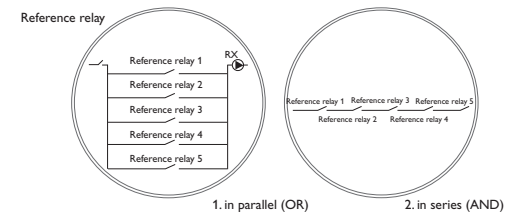
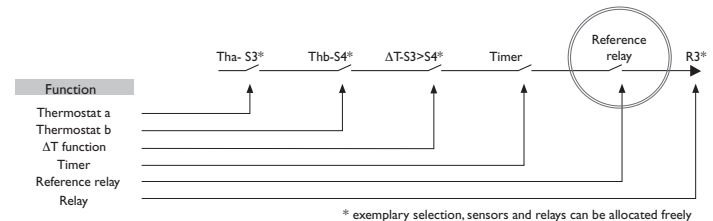

## Arrangement/Opt. functions/Add new function/Function block

Adjustment channel	Description	Adjustment range/selection	Factory setting
Relay	Relay	system dependent	system dependent
Thermostat a	Thermostat a	Yes, No	No
Th-a on	Switch-on temperature thermostat a	-40 ... 250 °C	40 °C
Th-a off	Switch-off temperature thermostat a	-40 ... 250 °C	45 °C
Sensor	Sensor thermostat a	system dependent	system dependent
Thermostat b	Thermostat b	Yes, No	No
Th-b on	Switch-on temperature thermostat b	-40 ... 250 °C	40 °C
Th-b off	Switch-off temperature thermostat b	-40 ... 250 °C	45 °C
Sensor	Sensor thermostat b	system dependent	system dependent
ΔT function	Differential function	Yes, No	No
ΔTon	Switch-on temperature difference	1.0 ... 50.0 K	5.0 K
ΔToff	Switch-off temperature difference	0.5 ... 49.5 K	3.0 K
ΔTset	Set temperature difference	2 ... 100 K	10 K
Rise	Rise	1.0 ... 20.0	2.0 K
Min speed	Minimum speed	20 ... 100%	30%
Sen. Source	Heat source sensor	system dependent	system dependent
Sen. Sink	Heat sink sensor	system dependent	system dependent
Timer	Timer option	Yes, No	No
Ref. relay	Reference relay option	Yes, No	No
Mode	Reference relay mode	AND, OR	OR
Relay	Reference relay 1 selection	system dependent	system dependent
Relay	Reference relay 2 selection	system dependent	system dependent
Relay	Reference relay 3 selection	system dependent	system dependent
Funct.	Activation / Deactivation	Activated / Deactivated	Activated

## Irradiation switch

Adjustment channel	Description	Adjustment range/selection	Factory setting
Irrad. switch	Irradiation switch	system dependent	system dependent
Relay	Relay selection	system dependent	system dependent
Irrad.	Switch-on irradiation	50 ... 1000 W/m <sup>2</sup>	200 W/m <sup>2</sup>
Duration	Switch-on duration	0 ... 30 min	2 min
Inverted	Inverted switching option	Yes, No	No
Funct.	Activation / Deactivation	Activated / Deactivated	Activated

## Arrangement/Opt. functions/Add new function/Irrad. switch

Adjustment channel	Description	Adjustment range/selection	Factory setting
Relay	Relay selection	system dependent	system dependent
Irrad.	Switch-on irradiation	50 ... 1000 W/m <sup>2</sup>	200 W/m <sup>2</sup>
Duration	Switch-on duration	0 ... 30 min	2 min
Inverted	Inverted switching option	Yes, No	No
Funct.	Activation / Deactivation	Activated / Deactivated	Activated

The **Irradiation switch** function can be used for operating a relay depending on the measured irradiation value.

The allocated relay is switched on if the adjusted irradiation value remains exceeded for the adjusted duration. If the irradiation falls below the adjusted value for the adjusted duration, the relay is switched off.

If the **Inverted** option is activated, the relay operates vice versa.

## Error relay

Adjustment channel	Description	Adjustment range/selection	Factory setting
Error relay	Error relay	system dependent	system dependent
Relay	Relay selection	system dependent	system dependent
Funct.	Activation / Deactivation	Activated / Deactivated	Activated

## Arrangement/Opt. functions/Add new function/Error relay

Adjustment channel	Description	Adjustment range/selection	Factory setting
Relay	Relay selection	system dependent	system dependent
Funct.	Activation / Deactivation	Activated / Deactivated	Activated

The **Error relay** function can be used for operating a relay in the case of an error. Thus, e. g. a signalling device can be connected in order to signal errors.

If the error relay function is activated, the allocated relay will operate when a sensor fault occurs.

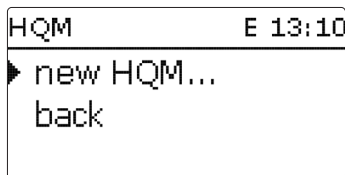

In the **HQM** menu, up to 5 internal heat quantity measurements can be activated and adjusted.

By selecting the menu item **new HQM...**, a new heat quantity measurement can be activated.

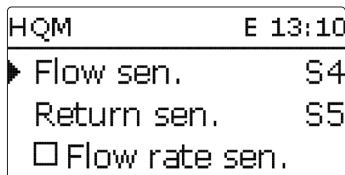

A menu opens in which all adjustments required for the heat quantity measurement can be made.

If the **Flow rate sensor** option is activated, an impulse input or, if available, a Grundfos Direct Sensor™ can be selected. Grundfos Direct Sensors™ are only available if they have been previously registered in the In-/Outputs menu. The impulse rate must be adjusted in that menu as well.

If the **Flow rate sensor** option is deactivated, the controller calculates the heat quantity by means of a fixed flow rate value. This is called heat quantity balancing. For this purpose, the flow rate must be read from the flowmeter at 100 % pump speed and adjusted in the adjustment channel **Flow rate**. In addition to that, a **Relay** must be allocated. Heat quantity balancing is in effect whenever the allocated relay is active.

In the adjustment channel **Fluid type** the heat transfer fluid must be selected. If either propylene glycol or ethylene glycol is selected, the adjustment channel **Ratio** is indicated in which the antifreeze ratio of the heat transfer fluid can be adjusted.

When the **Alternative unit** is activated, the controller will convert the heat quantity into the quantity of fossil fuels (coal, oil or gas) saved, or the CO<sub>2</sub> emission saved respectively. The alternative **Unit** can be selected. A **Conversion factor** must be adjusted for the calculation. The conversion factor depends on the arrangement in use and has to be determined individually.

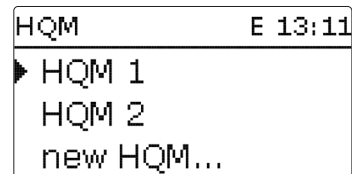

Heat quantity measurements already activated will appear in the HQM menu above the menu item **new HQM ...** in numerical order.

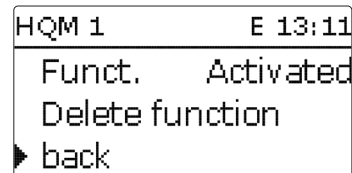

If an activated heat quantity measurement is selected, the above mentioned menu with all adjustment values will re-open.

To deactivate a heat quantity measurement, select the menu item **Delete function** at the bottom of the menu.

The heat quantity measurement deleted will disappear from the list and become available for selection in the **new HQM** menu again. The numeration of the other activated heat quantity measurements will not change.

## HQM / new HQM...

Adjustment channel	Description	Adjustment range / selection	Factory setting
Flow sen.	Flow sensor selection	system dependent	system dependent
Return sen.	Return sensor selection	system dependent	system dependent
Flow rate sen.	Flow rate sensor option	Yes, No	No
Flow rate sen.	Flow rate sensor selection	Imp 1, Gd1, Gd2	-
Flow r..	Flow rate (only if Flow rate sen. = No)	1.0 ... 500.0 l/min	3.0 l/min
Relay	Relay selection	system dependent	system dependent
Fluid type	Heat transfer fluid	Tyfocor LS, Propylene glycol, Ethylene glycol, Water	Water
Ratio	Glycol ratio in the heat transfer fluid (only if Fluid type = Propylene glycol or Ethylene glycol)	5 ... 100%	40%
Alternative unit	Alternative unit option	Yes, No	No
Unit	Alternative display unit	Coal, Gas, Oil, CO <sub>2</sub>	CO <sub>2</sub>
Factor	Conversion factor	0.01 ... 100.00	0.50
Funct.	Activation / Deactivation	Activated / Deactivated	Activated

## 9 Basic settings

Basic settings	E 13:12
▶ Language	English
<input checked="" type="checkbox"/> Auto DST	
Date	01.07.2015

### Basic settings

Adjustment channel	Description	Adjustment range / selection	Factory setting
Language	Selection of the menu language	Deutsch, English, Français, Español, Italiano, Nederlands, Türkçe, Český, Polski, Portugues, Hrvatski, Română, Български, Русский, Suomi, Svenska, Magyar	Deutsch
Auto DST	Daylight savings time selection	Yes, No	Yes
Date	Adjustment of the current date	01.01.2001 ... 31.12.2099	01.07.2015
Time	Adjustment of the current time	00:00 ... 23:59	-
Temp. Unit	Temperature unit	°C, °F	°C
Flow Unit	Volume unit	Gallons, Liter	Liter
Press. unit	Pressure unit	psi, bar	bar
Energy Unit	Energy unit	Wh, BTU	Wh
Scheme	Scheme selection	0 ... 9, 202 ... 809	0
Reset	back to factory setting	Yes, No	No

In the **Basic settings** menu, all basic parameters for the controller can be adjusted. Normally, these settings have been made during commissioning. They can be subsequently changed in this menu.

### Reset

By means of the reset function, all adjustments can be set back to their factory settings.

All adjustments that have previously been made will be lost! For this reason, a security enquiry will appear after the reset function has been selected.

Only confirm the security enquiry if you are sure you want to set back all adjustment to the factory setting.



### Note:

If you select a new scheme, all adjustments that have previously been made will be lost.



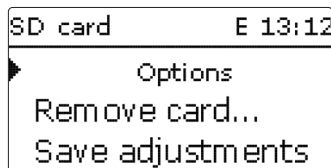

The controller is equipped with an SD card slot for SD memory cards.

With an SD card, the following functions can be carried out:

- Logging measurement and balance values. After the transfer to a computer, the values can be opened and visualised, e. g. in a spreadsheet.
- Store adjustments and parameterisations on the SD card and, if necessary, retrieve them from there.
- Running firmware updates on the controller.

### Running firmware updates

The current software can be downloaded from [www.resol.de/firmware](http://www.resol.de/firmware). When an SD card with a firmware update is inserted, the enquiry **Update?** is indicated on the display. The setting can be changed between **Yes** and **No** by pressing buttons **2** and **4**.

➔ To run the update, select **Yes** and confirm by pressing button **5**.

The update is run automatically. The indication **Please wait** and a progress bar appear on the display. When the update has been completed, the controller will automatically reboot and run a short initialisation phase.

➔ To skip the update, select **No**.

The controller starts normal operation.



#### Note:

The controller will only recognise a firmware update file if it is stored in a folder named **RESOLHC** on the first level of the SD card.

➔ Create a folder named **RESOLHC** on the SD card and extract the downloaded ZIP file into this folder.

### Starting the logging

1. Insert the SD card into the slot
2. Adjust the desired logging type and interval

Logging will start immediately.

### Completing the logging process

1. Select the menu item **Remove card**
2. After **Remove card** is displayed, remove the card from the slot.

When **Linear** is adjusted in the **Logging type** adjustment channel, data logging will stop if the capacity limit is reached. The message **Card full** will be displayed.

If **Cyclic** is adjusted, the oldest data logged onto the SD card will be overwritten as soon as the capacity limit is reached.



#### Note:

Because of the increasing size of the data packets, the remaining logging time does not decrease linearly. The data packet size can increase, e. g. with the increasing operating hours value.

### Storing controller adjustments

➔ To store the controller adjustments on an SD card, select the menu item **Save adjustments**.

While the adjustments are being stored, first **Please wait**, then **Done!** will be indicated on the display. The controller adjustments are stored as a .SET file on the SD card.

### Loading controller adjustments

1. To load controller adjustments from an SD card, select the menu item **Load adjustments**.

The File selection window is indicated.

2. Select the desired .SET file.

While the adjustments are being loaded, first **Please wait**, then **Done!** will be indicated on the display.

### Formatting the SD card

➔ Select the menu item **Format card**

The content of the card will be deleted and the card will be formatted with the FAT file system.



#### Note:

To safely remove the SD card, always select the menu item **Remove card ...** before removing the card.

### SD card

Adjustment channel	Description	Adjustment range/ selection	Factory setting
Remove card...	Safely remove card	-	-
Save adjustments	Save adjustments	-	-
Load adjustments	Load adjustments	-	-
Logging int...	Logging interval	00:01 ... 20:00 (mm:ss)	01:00
Logging type	Logging type	Cyclic, Linear	Linear
Format card	Format card	-	-

## 11 Manual mode

```

Manual mode   E 13:12
              Controller
▶ Relay 1     Auto
Relay 2     Auto
    
```

In the **Manual mode** menu, the operating mode of all relays in the controller and in connected modules can be adjusted.

All relays are displayed in numerical order, first those of the controller, then those of the individual modules connected. Modules are listed in numerical order.

In the menu item **All relays...**, all relays can be switched off (Off) or set to automatic mode (Auto) at once:

Off = Relay is switched off (manual mode)

Auto = Relay is in automatic mode

```

Relay 1
○ Max
▶ ● Auto
○ Min
    
```

The operating mode can be selected for each individual relay, too. The following options are available:

Off = Relay is switched off (manual mode)

Min = Relay active with minimum speed (manual mode)

Max = Relay active at 100% speed (manual mode)

Auto = Relay is in automatic mode



### Note:

After service and maintenance work, the relay mode must be set back to **Auto**. Normal operation is not possible in manual mode.

### Manual mode

Adjustment channel	Description	Adjustment range/selection	Factory setting
Relay 1...X	Operating mode selection	Max, Auto, Min, Off	Auto
All relays...	Operating mode of all relays	Auto, Off	Off

## 12 User code

```

User code:
          0000
          ▲
    
```

The access to some adjustment values can be restricted via a user code (customer).

To access the menu areas of the expert level, the expert user code must be entered:

Expert user code: 0262

If the expert user code is active, an E will be displayed next to the clock time.

```

HC 1           E 12:23
▶ Op. mode     Auto
Status         Day
Flow           40 °C
    
```

For safety reasons, the user code should generally be set to the customer code before the controller is handed to the customer!

Customer user code: 0000



### Note:

If no entry is made for 30min, the controller will automatically switch back to the customer level (0000).

## 13 In-/Outputs

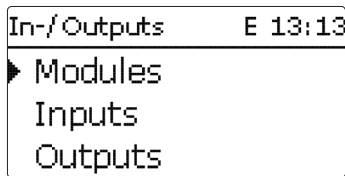

In the **In-/Outputs** menu, external modules can be registered, sensor offsets can be adjusted and relay outputs can be configured.

### 13.1 Modules

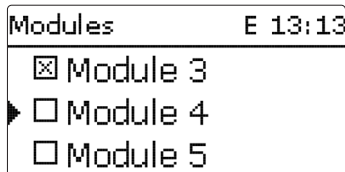

In this menu, up to 5 external modules can be registered.

All modules connected and acknowledged by the controller are available.

➔ To register a module, select the corresponding menu item by pressing button .

If a module is registered, all its sensor inputs and relay outputs will be available in the corresponding controller menus.

#### In-/Outputs/Modules

Adjustment channel	Description	Adjustment range/selection	Factory setting
Module 1...5	Registering external modules	-	-

## 13.2 Inputs

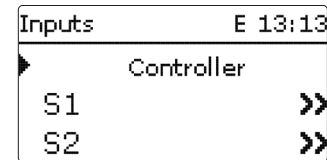

In this sub-menu, the type of the sensor connected can be adjusted for each individual input. The following types can be selected:

- Switch
- KTY
- Pt500
- OMS (room control unit)
- Remote control
- Pt1000
- None

#### ATTENTION! System damage!







Selecting the wrong sensor type will lead to unwanted control behavior. In the worst case, system damage can occur!

➔ **Make sure that the right sensor type is selected!**

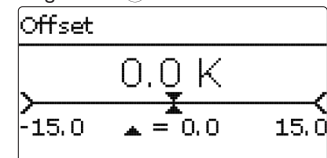
If KTY, Pt500 or Pt1000 is selected, the channel **Offset** appears, in which an individual offset can be adjusted for each sensor.

1. In order to select a sensor for the offset adjustment, select the corresponding menu item by pressing button .



2. To adjust the sensor offset, select the desired value by pressing buttons  or , then confirm by pressing button .

## Irradiation sensor offset

If an irradiation sensor is to be connected, an offset has to be carried out before the connection is made.

To carry out the offset, proceed as follows:

1. Adjust the irradiation sensor type in the **Type** channel.
2. Select the **Offset** channel.
3. Confirm the reset enquiry with **Yes**.
4. Select **back** to return to the **Inputs** menu, then connect the irradiation sensor.

## In-/Outputs/Inputs

Adjustment channel	Description	Adjustment range/ selection	Factory setting
S1 ... S9	Sensor input selection	-	-
Type	Selecting the sensor type	Switch, KTY, Pt500, Remote control, Pt1000, OMS, Impulse (S9 only), None	Pt1000
Offset	Sensor offset	-15.0 ... +15.0 K	0.0 K
Inverted	Inverted switching option (only if Type = Switch)	Yes, No	No
Imp.1	Impulse input (only if Type = Impulse)	-	-
Vol./Imp.	Impulse rate (only if Type = Impulse)	0.1 ... 100.0	1.0
CS10	Irradiation sensor input	-	-
Type	Irradiation sensor type	A ... K	E
Offset	Delete offset	Yes, No	No
Gd1, 2	Grundfos Direct Sensor™ digital 1, 2	-	-
Type	Grundfos Direct Sensor™ Type	RPD,VFD, None	None
	if Type = VFD: Measuring range selection	10-200 l/min, 5-100 l/min, 2-40 l/min, 2-40 l/min (fast), 1-20 l/min, 1-12 l/min*	1-12 l/min

\* For the Inputs Gd1 and Gd2, the following sensor combinations are possible:  
 - 1 x RPD, 1 x VFD  
 - 2 x VFD, but with different measuring ranges only

## 13.3 Outputs

Outputs	E 13:13
▶ R1	>>
R2	>>
R3	>>

In this menu, the control type and the minimum speed can be adjusted for each individual relay of the controller and the external modules.

R1	E 13:14
Signal	PWM
Output	B
▶ Profile	Heating

The control type determines the way speed control of a connected pump is effected. The following modes are available:

**Adapter** = speed control signal via a VBus®/PWM interface adapter

**0-10V** = Speed control via a 0-10V signal

**PWM** = Speed control via a PWM signal

**Standard** = Burst control (factory setting)

With the control types **Adapter**, **0-10 V** and **PWM**, the relay itself is not involved in speed control. A separate connection for the corresponding signal will have to be made (see figure).

If **PWM/0-10 V** is selected, the channels **Output** and **Profile** appear. In the **Output** channel, one of the 2 PWM outputs can be selected. In the **Profile** channel, different PWM curves corresponding with the pump in use can be selected.

In order to reduce the number of switching processes for high-efficiency pumps, the controller is equipped with a relay overrun function that automatically comes into effect when the speed control signal is not issued by the relay itself. The corresponding relay will then remain switched on for an hour after the switch-off conditions are fulfilled.

**Note:**

If **PWM/0-10V** is selected for an output, the adjustment range for the corresponding minimum speed will extend to 20 ... 100 %.

**Note:**

For boiler modulation, the 0-10V outputs A and B can be allocated to a demand in the **Shared relays** menu.

**In- /Outputs/Outputs**

Adjustment channel	Description	Adjustment range/ selection	Factory setting
R1 ... R5	Relay output selection	-	-
Signal	Control type	Adapter, 0-10V, PWM, Standard	Standard
Output	PWM output selection	A, B	A
Profile	PWM characteristic curve	Solar, Heating	Solar
Min speed	Minimum speed	(20) 30 ... 100 %	30 %

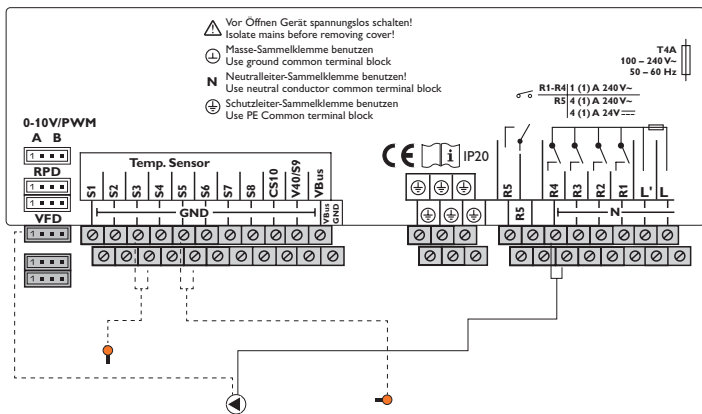
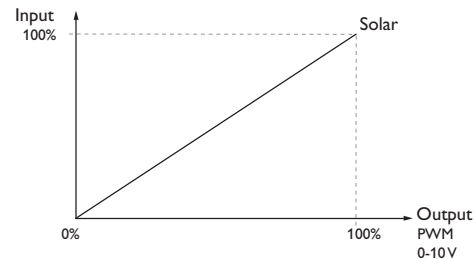
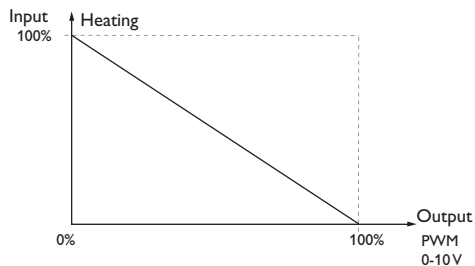
**Characteristic curve profile Solar****Characteristic curve profile Heating****Note:**

When the minimum pump speed value adjusted in the Outputs menu differs from the minimum pump speed adjusted in an optional function that uses the same output, only the higher value will be come into effect.

## 14 Troubleshooting

If a malfunction occurs, a message will appear on the display of the controller.

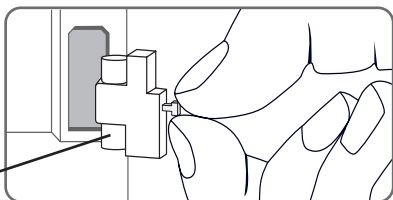

Fuse

Directional pad flashes red.

Sensor fault. The message **!Sensor fault** instead of a temperature is shown on the sensor display channel.

Short circuit or line break.  
Disconnected temperature sensors can be checked with an ohmmeter. Please check if the resistance values correspond with the table.

°C	°F	Ω Pt500	Ω Pt1000	Ω KTY	°C	°F	Ω Pt500	Ω Pt1000	Ω KTY
-10	14	481	961	1499	55	131	607	1213	2502
-5	23	490	980	1565	60	140	616	1232	2592
0	32	500	1000	1633	65	149	626	1252	2684
5	41	510	1019	1702	70	158	636	1271	2778
10	50	520	1039	1774	75	167	645	1290	2874
15	59	529	1058	1847	80	176	655	1309	2971
20	68	539	1078	1922	85	185	664	1328	3071
25	77	549	1097	2000	90	194	634	1347	3172
30	86	559	1117	2079	95	203	683	1366	3275
35	95	568	1136	2159	100	212	693	1385	3380
40	104	578	1155	2242	105	221	702	1404	3484
45	113	588	1175	2327	110	230	712	1423	3590
50	122	597	1194	2413	115	239	721	1442	3695

### WARNING! Electric shock!



Upon opening the housing, live parts are exposed!

→ **Always disconnect the device from power supply before opening the housing!**

The controller is protected by a fuse. The fuse holder (which also holds the spare fuse) becomes accessible when the cover is removed. To replace the fuse, pull the fuse holder from the base.

The display is permanently off.

Press button . Display illuminated?

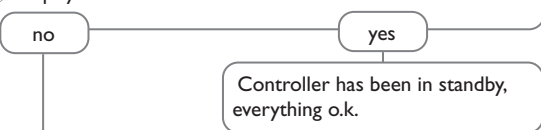

Check the power supply of the controller. Is it disconnected?

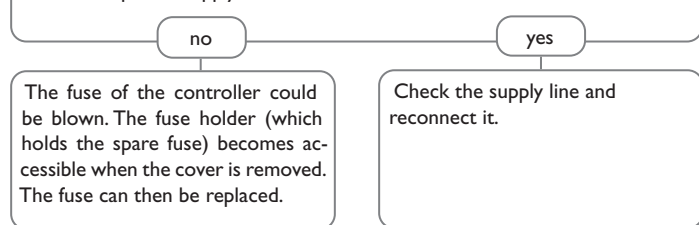

### Note:

For answers to frequently asked questions (FAQ) see [www.resol.com](http://www.resol.com).

The heating circuit pump does not work, although this is indicated on the display.

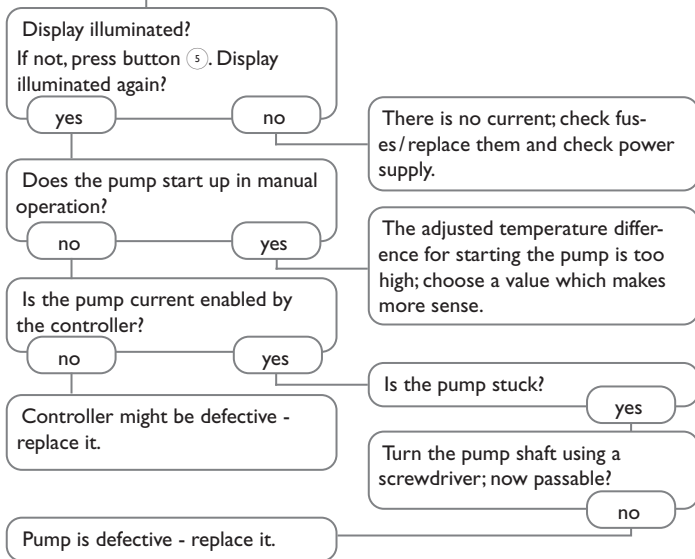

Stores cool down at night.

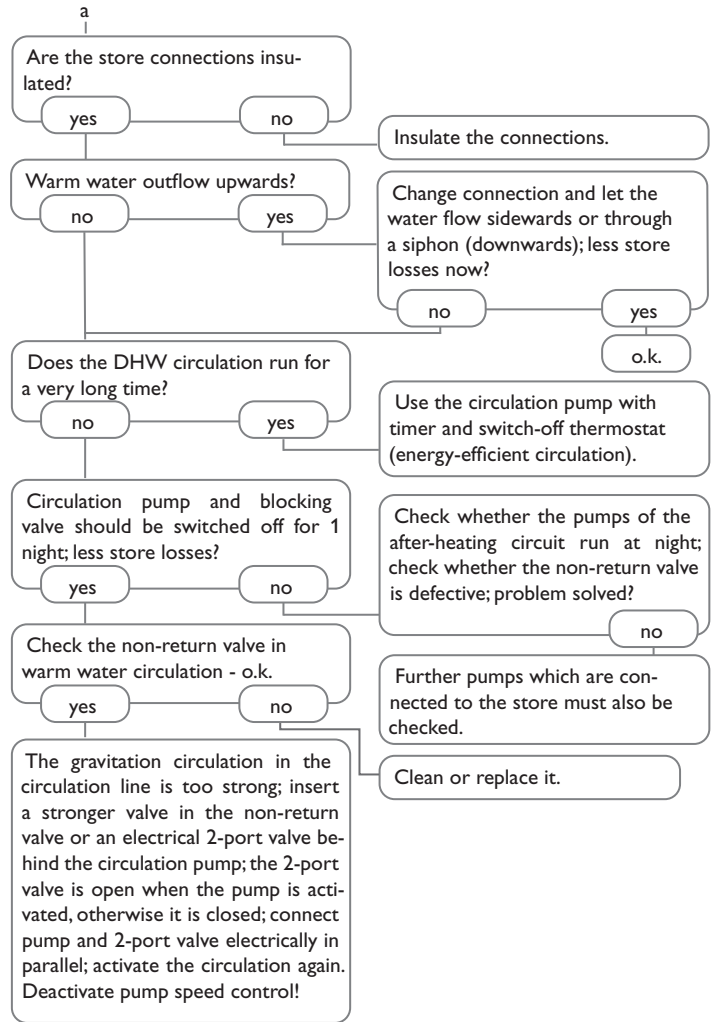
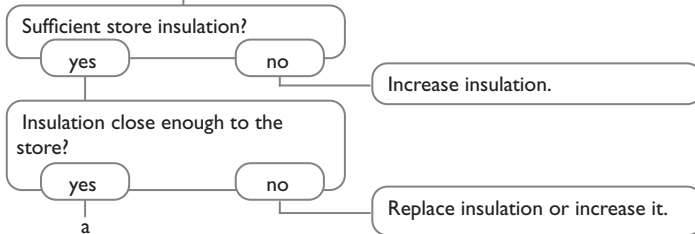

# 15 Accessories

en

Installation

Commissioning

Settings

Data communication

Troubleshooting



Sensors



RCP12 Room control unit



RTA12 Remote control



VFD and RPD Grundfos Direct Sensors™



V40 Flowmeter



VBus®Touch HC

ErP 6 kit/  
ErP 8 kit  
(s. page 66)



AM1 Alarm module



EM Extension Module



DL2 Datalogger



KM2 Communication module



VBus®/USB & VBus®/LAN interface adapters



## 15.1 Sensors and measuring instruments

### Sensors

The product range includes high-precision platinum temperature sensors, flatscrew sensors, outdoor temperature sensors, indoor temperature sensors, cylindrical clip-on sensors, also as complete sensors with immersion sleeve.

### RCP12 Room control unit

With the RTA12 Room control unit, the heating curve can be comfortably adjusted from the living area. The integrated sensor measures the ambient temperature.

### RTA12 Remote control

With the RTA12, the heating curve can be comfortably adjusted from the living area.

### VFD and RPD Grundfos Direct Sensors™

The RPD Grundfos Direct Sensor™ is a digital sensor that measures both temperature and pressure.

The VFD Grundfos Direct Sensor™ is a digital sensor that measures both temperature and flow rate.

### V40 Flowmeter

The V40 is a measuring instrument for detecting the flow of water or water/glycol mixtures.

## 15.2 VBus® accessories

### AM1 Alarm module

Alarm module for signalling system failures.

### EM Extension Module

Sensor and relay Extension module with 5 outputs and 6 inputs.

### DL2 Datalogger

For visualisation via VBus.net, incl. SD card and network cable, mains adapter and VBus® cable pre-connected.

### KM2 Communication module

The KM2 Communication module is the ideal interface between a solar or heating controller and the Internet. In only a few steps, the controller can be connected to the VBus.net visualisation portal.

### VBus®Touch HC

This easy-to-use app enables you to make adjustments on your heating controller (DeltaTherm® HC and HC mini) from a mobile device.

Thus, e.g. the operating mode can be set via the app. Additionally, the system data are displayed in a clearly arranged graphic.



VBus® is a registered trademark of RESOL GmbH  
Google Play is a trademark of Google Inc.

Apple, the Apple logo, iPad, and iPhone are trademarks of Apple Inc., registered in the U.S. and other countries. App Store is a service mark of Apple Inc.

## 15.3 Interface adapters

### VBus®/USB & VBus®/LAN interface adapters

With the VBus®/USB interface adapter, the controller can be connected to the USB port of a PC via the VBus®.

The VBus®/LAN interface adapter is designed for the direct connection of the controller to a PC or router. It enables easy access to the controller via the local network of the owner.

## ErP 6 kit

### DeltaTherm® HC

#### + FAP13 Outdoor temperature sensor

The FAP13 is used for measuring the outdoor temperature with a Pt1000 measuring element

#### + RCP12 Room control unit

With the RCP12, the heating curve can be comfortably adjusted from the living area. The integrated sensor measures the room temperature.

The additional operating mode switch enables a quick change of modes, e. g. from Automatic to Night mode.

#### + FRP21 Cylindrical clip-on sensor

For surface mounting on tubes, Pt1000 version

#### + FRP6 Temperature sensor

For installation into immersion sleeves

## ErP 8 kit

### DeltaTherm® HC

#### + FRP12 Indoor temperature sensor

Used for measuring the indoor temperature with a Pt1000 measuring element

#### + RCP12 Room control unit

With the RCP12, the heating curve can be comfortably adjusted from the living area. The integrated sensor measures the room temperature.

The additional operating mode switch enables a quick change of modes, e. g. from Automatic to Night mode.

#### + FRP21 Cylindrical clip-on sensor

For surface mounting on tubes, Pt1000 version

#### + FRP6 Temperature sensor

For installation into immersion sleeves

## 16 Index

### Symbols

$\Delta T$  function..... 53

### A

Antifreeze function..... 38

Automatic mode..... 26

### B

Backup heating..... 36

Balance values..... 29

Basic system..... 15

Boiler loading pump..... 36

### C

Chimney sweeper function..... 9, 38

Circulation..... 45

Commissioning menu..... 14

Controller adjustments, loading of..... 57

Controller adjustments, storing of..... 57

Correction modes..... 37

Countdown..... 38

### D

Data logging..... 57

Day correction..... 33

Day/Night operation..... 35

Day operation..... 37

DHW heating..... 43

DHW priority..... 37

### E

ErP Directive..... 16

Error relay..... 54

### F

Firmware updates..... 57

Function block..... 53

Fuse, replacing of..... 62

<b>H</b>			
Heat exchange .....	50	<b>R</b>	
Heating circuit mixer .....	33	Registering external modules .....	59
Heating circuit pump .....	33	Remote access .....	37
Heating curve .....	33	Remote control .....	33
Heat quantity measurement .....	55	Return preheating .....	51
Holiday .....	28	Room control .....	35
<b>I</b>		Room control unit .....	37
Interval .....	33	Room influence .....	34
Irradiation switch .....	54	Room thermostat .....	35
<b>L</b>		<b>S</b>	
Limit temperature .....	36	Scheme .....	15
Linking .....	38	Screed drying .....	40
<b>M</b>		Sensor fault, error message .....	29
Mains connection .....	7	Sensor offset .....	59
Maximum flow temperature .....	33	Set flow temperature .....	33
Meas. values .....	29	Shared relays .....	30
Messages .....	29	Solid fuel boiler .....	52
Minimum flow temperature .....	33	Starting time .....	37
Mixer .....	48	Start temperature .....	40
Mixer runtime .....	33	Start-up .....	32
Modulating heating control .....	32	Summer mode .....	36
<b>N</b>		<b>T</b>	
Night correction .....	33	Technical data .....	5
Night operation .....	36	Temperature controls class .....	16
<b>O</b>		Thermal disinfection .....	44
Offset .....	59	Thermostat .....	36
Operating mode, relays .....	58	Thermostat function .....	53
Operating mode switch .....	37	<b>U</b>	
Operation mode .....	26	User code .....	58
Overrun .....	32	<b>V</b>	
<b>P</b>		Virtual .....	30
Parallel relay .....	48	<b>Z</b>	
PWM speed control .....	60	Zone .....	36
		Zone loading .....	49

Distributed by:

**RESOL – Elektronische Regelungen GmbH**

Heiskampstraße 10  
45527 Hattingen / Germany

Tel.: +49 (0) 23 24 / 96 48 - 0

Fax: +49 (0) 23 24 / 96 48 - 755

[www.resol.com](http://www.resol.com)

[info@resol.com](mailto:info@resol.com)

**Important note**

The texts and drawings in this manual are correct to the best of our knowledge. As faults can never be excluded, please note:

Your own calculations and plans, under consideration of the current standards and directions should only be basis for your projects. We do not offer a guarantee for the completeness of the drawings and texts of this manual - they only represent some examples. They can only be used at your own risk. No liability is assumed for incorrect, incomplete or false information and / or the resulting damages.

**Note**

The design and the specifications can be changed without notice.

The illustrations may differ from the original product.

**Imprint**

This mounting- and operation manual including all parts is copyrighted. Another use outside the copyright requires the approval of **RESOL – Elektronische Regelungen GmbH**. This especially applies for copies, translations, micro films and the storage into electronic systems.

© **RESOL – Elektronische Regelungen GmbH**