

RESOL DeltaSol[®] BS/2 (Version 2)

Mounting

Connection

Application examples

Operation

Troubleshooting



48005401

**Thank you for buying this RESOL product.
Read this manual carefully to get the best performance from this unit.
Please keep this manual carefully.**

DeltaSol[®] BS/2

en-US/CA

Manual

www.resol.com

Contents

General	2	2.3 Flashing codes	9
Overview	3	3. Commissioning	10
1. Installation	4	4. Channel overview	12
1.1 Mounting	4	4.1 Display channels	12
1.2 Electrical connection	4	4.2 Adjustment channels	14
1.3 Data communication/ Bus	5	5. Troubleshooting	21
1.4 Terminal allocation	6	5.1 Various	22
2. Operation and function	8	6. Accessories	24
2.1 Push buttons	8	Imprint	28
2.2 System monitoring display	8		

General

Safety advice:

Please read the following information carefully before installing and operating the controller. In this way damage to the solar system caused by wrong installation will be avoided. Please make sure that the mounting is adapted to the characteristics of the building, that the local regulations are respected and is conform with the technical rules.

Please pay attention to the following safety advice in order to avoid danger and damage to people and property.

Subject to technical change. Errors excepted.

Instructions:

Attention should be paid to

- Valid national and local standards and regulations
- Respective valid standards and directives

Equipment to be installed and used in accordance with the rules of the National Electrical Code (NEC) or with Canadian Electrical Code (CEC), Part I.

These instructions are exclusively addressed to authorized skilled personnel.

- Only qualified electricians should carry out installation and maintenance work.
- Initial installation should be carried out by qualified personnel

Description of symbols

WARNING!	Warnings are indicated with a warning triangle! → They contain information on how to avoid the danger described.

Signal words describe the danger that may occur, when it is not avoided.

Warning means that injury, possibly life-threatening injury, can occur.

Attention means that damage to the appliance can occur.



Note

Notes are indicated with an information symbol.

→ Arrows indicate instruction steps that should be carried out.

Information about the product

Proper usage

The solar controller is designed for use in solar thermal and heating systems in compliance with the technical data specified in these instructions.

Improper use excludes all liability claims.



Note

Strong electromagnetic fields can impair the function of the controller.

→ Make sure the controller as well as the system are not exposed to strong electromagnetic fields.

Overview

- System-monitoring-display
- Up to 4 Pt1000 temperature sensors
- Semiconductor relay for pump speed control
- Energy metering
- VBus®
- Function control
- Control of the system by ServiceCenter software possible
- User-friendly operation
- Housing with outstanding design
- Extra-low power consumption
- HE pump control via adaptor



Included with the BS/2:

- 1 × DeltaSol® BS/2
- 1 × accessory bag
 - 1 × spare fuse T4A
 - 2 × screws and wall plugs
 - 4 × strain relief and screws
- 1 × manual

Additionally enclosed in the full kit:

- 1 × sensor FKP6
- 2 × sensor FRP6

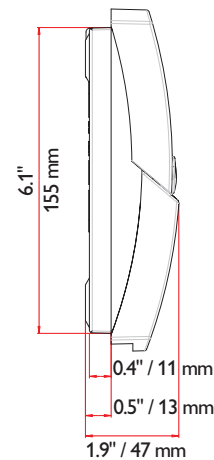
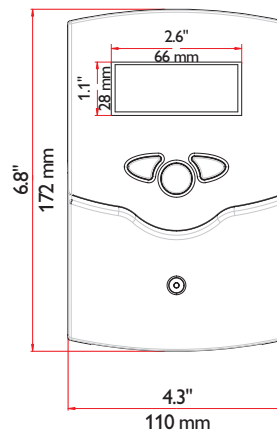

Technical data

Housing: plastic, PC-ABS and PMMA

Protection type: IP 20 / EN 60529

Ambient temp.:

32 ... 104 °F

[0 ... 40 °C]

Size:

6.8" × 4.3" × 1.9"

172 × 110 × 47 mm

Mounting: wall mounting, mounting into patch-panels is possible

Display: System screen for system visualization, 16-segment display, 7-segment display, 8 symbols for system status and operating control lamp

Operation: by 3 push buttons at the front of the housing

Functions: Differential temperature controller with optional add-on system functions. Function control, operating hours counter for solar pump, pump speed control, drainback option and energy metering.

Inputs:

for 4 Pt1000 temperature sensors

Output: 1 semiconductor relay

Bus: VBus®

Power supply: 100 – 240 V~

Standby power consumption: < 1 W

Switching capacities:

R1: 1 (1) A 100 – 240 V~
(semiconductor relay)

1. Installation

1.1 Mounting

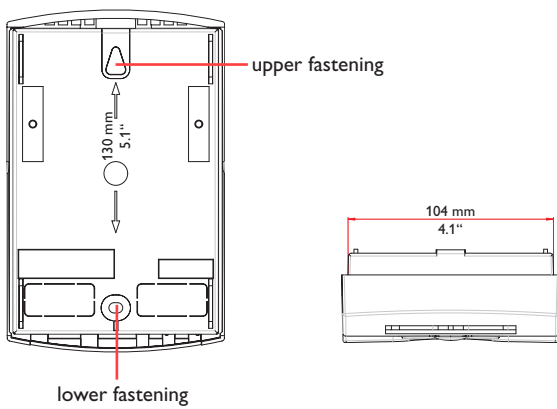
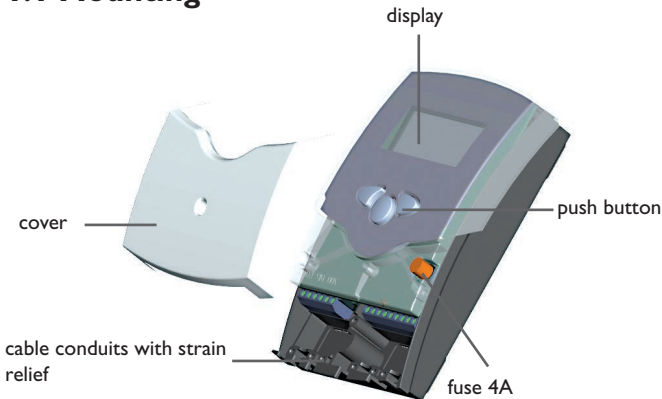

	WARNING! Electric shock!
	Opening the housing will expose live parts! → Switch off power supply and disconnect the device from power supply before opening the housing!

- The unit must only be installed
- in a dry interior location
 - in a non-hazardous location
 - away from electromagnetic fields

The controller must additionally be supplied from a double-pole switch with contact gap of at least 0.12" [3 mm].

Route sensor cables and power supply cables separately.

- Unscrew the cross-head screw from the cover and remove it along with the cover from the housing
- Mark the upper fastening point on the wall and drill
- Fasten the enclosed wall plug and screw leaving the head protruding
- Hang the housing from the upper fastening point and mark the lower fastening point through the hole in the terminal box (centers 5.1" [130 mm])
- Drill and insert the lower wall plug
- Fasten the housing to the wall with lower fastening screw and tighten
- Complete wiring connections in accordance with terminal allocations, see chap. 1.2 "Electrical connection"
- Place the cover back onto the housing
- Fasten the cover by means of the cross-head screw

1.2 Electrical connection

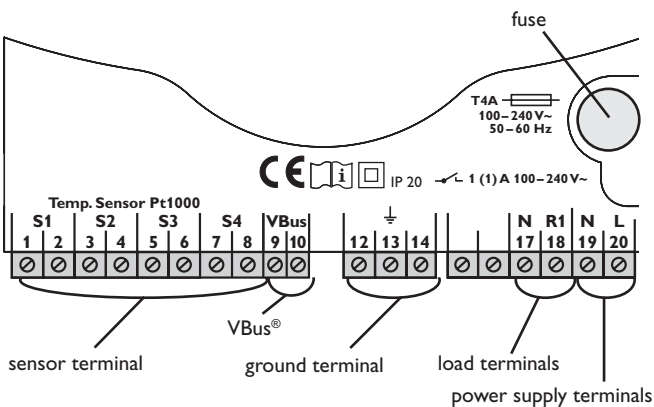

	ATTENTION! ESD damage!
	Electrostatic discharge can lead to damage to electronic components! → Take care to discharge properly before touching the inside of the device. To do so, touch a grounded surface such as a radiator or tap!

Note: The minimum pump speed must be set to 100 % when auxiliary relays or valves are connected.

Connecting the device to the power supply must always be the last step of the installation!

The power supply to the controller must be carried out via an external power switch (last step!). The supply voltage must be 100 ... 240 V~ (50 ... 60 Hz). Flexible cables must be attached to the housing with the enclosed strain relief and the corresponding screws.

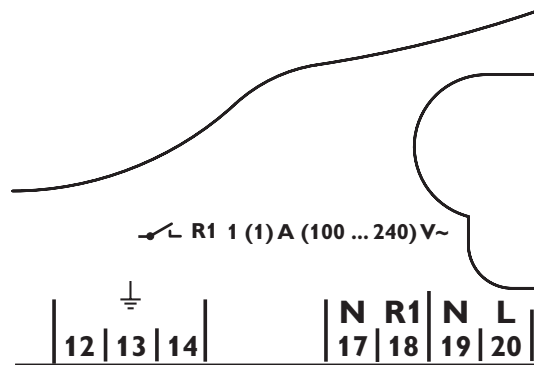

Grounding and load terminals

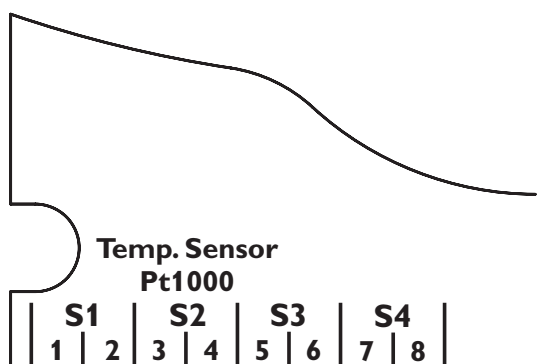

Sensor terminals S1 ... S4

The controller is equipped with a semiconductor relay, to which a **load** such as a pump, a valve etc. can be connected:

- Relay 1
 - 18 = conductor R1
 - 17 = neutral conductor N
 - 13 = ground conductor

The **power supply** is to be carried out at the terminals:

- 19 = neutral conductor N
- 20 = conductor L
- 12 = ground terminal

The **temperature sensors** (S1 up to S4) are to be connected to the following terminals with either polarity:

- 1 / 2 = Sensor 1 (e.g. Sensor collector)
- 3 / 4 = Sensor 2 (e.g. Sensor tank)
- 5 / 6 = Sensor 3 (e.g. Sensor tank top)
- 7 / 8 = Sensor 4 (e.g. Sensor return)

All Pt1000 temperature sensors are equipped with a platinum measuring element in their tip. The electrical resistance of the measuring element changes in relation to the temperature (see table in chap. 5).

The difference between **FKP** and **FRP** type sensors only lies in the cable insulation material. The insulation material of FKP type sensor cables resists a higher temperature, so that FKP type sensors should be used as collector sensors. FRP type sensors are best used as reference sensors in tanks or pipes.

1.3 Data communication/ Bus

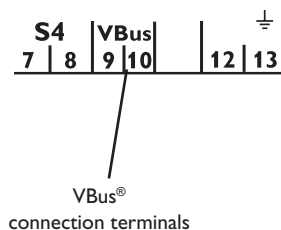

The controller is equipped with a RESOL **VBus**® for data transfer with and energy supply to external modules. The connection is carried out at the terminals marked “VBus” (either polarity). One or more RESOL VBus® modules can be connected via this data bus, such as

- GA3 large display, SD3 smart display
- DL2 datalogger
- VBus®/USB or VBus®/LAN interface adaptor
- VBus®/PWM interface adaptor
- AM1 alarm module
- WMZ calorimeter module

By means of a DL2 datalogger or an interface adaptor, the controller can be connected to a PC or a computer network. With the RESOL ServiceCenter Software (RSC) the controller measurements can be read out, processed and visualized. The software allows easy function control of the system. For the remote parametrisation of the controller, a special software tool will be available for download, soon.

1.4 Terminal allocation

The controller calculates the temperature difference between collector sensor S1 and tank sensor S2. If the difference is larger than or identical to the adjusted switch-on temperature difference (DT O), the solar pump will be operated by R1, and the tank will be loaded until the switch-off temperature difference (DT F) or the maximum tank temperature (S MX) is reached.

Sensors S3 and S4 can optionally be connected for measurement purposes. S3 can optionally be used as reference sensor for the tank emergency shutdown option (OSEM). If heat quantity measurement (OHQM) is activated, sensor S4 has to be connected as return sensor.

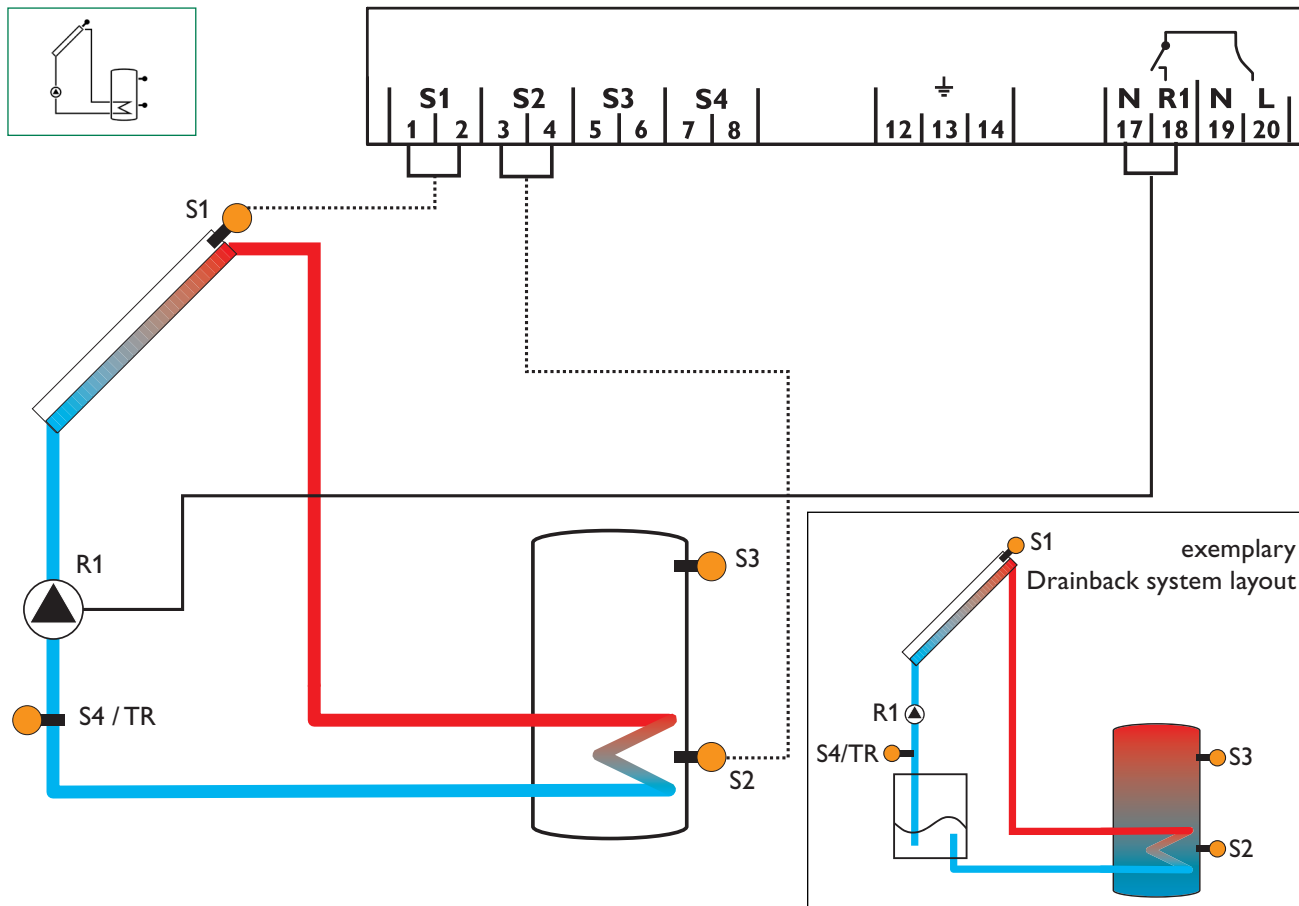

Display Channels				
Channel		Description	Terminal	Page
INIT	x*	ODB initialization active	-	12
FLL	x*	ODB filling time active	-	12
STAB	x*	ODB stabilization in progress	-	12
COL	x	Temperature collector	S1	12
TST	x	Temperature tank	S2	12
S3	x	Temperature sensor 3	S3	12
TSTT	x*	Temperatur tank at the top	S3	12
S4	x	Temperature sensor 4	S4	12
TR	x*	Temperature return sensor	S4	12
n %	x	Pump speed R1	R1	13
hP	x	Operating hours R1	R1	13
kWh	x*	Heat quantity kWh	-	13
MWh	x*	Heat quantity MWh	-	13

Adjustment Channels				
Channel		Description	Factory setting	Page
DT O	x	Switch-on temperature difference	12.0 °Ra [6.0 K]	14
DT F	x	Switch-off temperature difference	8.0 °Ra [4.0 K]	14
DT S	x	Nominal temperature difference	20.0 °Ra [10.0 K]	14
RIS	x	Rise control	4 °Ra [2 K]	14
nMN	x	Minimum pump speed	30 %	14
S MX	x	Maximum tank temperature	140 °F [60 °C]	15
OSEM	x	Option tank emergency shutdown	OFF	15
EM	x	Emergency temperature collector	270 °F [130 °C]	15
		Emergency temperature collector if ODB is activated:	200 °F [95 °C]	15
OCC	x	Option collector cooling	OFF	16
CMX	x*	Maximum collector temperature	230 °F [110 °C]	16
OSYC	x	Option system cooling	OFF	16
DTCO	x*	Cooling switch-on temperature difference	40.0 °Ra [20.0 K]	16
DTCF	x*	Cooling switch-off temperature difference	30.0 °Ra [15.0 K]	16
OSTC	x	Option tank cooling	OFF	17
OHOL	x*	Option holiday cooling	OFF	17
THOL	x*	Holiday cooling temperature	110 °F [40 °C]	17
OCN	x	Option minimum limitation	OFF	17
CMN	x*	Minimum collector temperature	50 °F [10 °C]	17
OCF	x	Option antifreeze	OFF	17
CFR	x*	Antifreeze temperature	40.0 °F [4.0 °C]	17
OHQM	x	Option energy metering	OFF	18
FMAX	x*	Maximum flow	6.0 l	18
MEDT	x*	Antifreeze type	1	18
MED%	x*	Antifreeze concentration (only if MEDT = propylene or ethylene)	45 %	18
ODB	x	Drainback option	OFF	19
tDTO	x*	ODB switch-on condition - time period	60 s	19
tFLL	x*	ODB filling time	5.0 min	19
tSTB	x*	ODB stabilization time	2.0 min	19
MAN1	x	Manual operation R1	Auto	20
ADA1	x	HE pump control	OFF	20
LANG	x	Language	En	20
UNIT	x	Temperature unit	°C	20
RESE	x	Reset - back to factory defaults		20
W0020100		Version number		

Legend:

Symbol	Specification
x	Channel is available
x*	Channel is available if the corresponding option is activated.

2. Operation and function

2.1 Push buttons

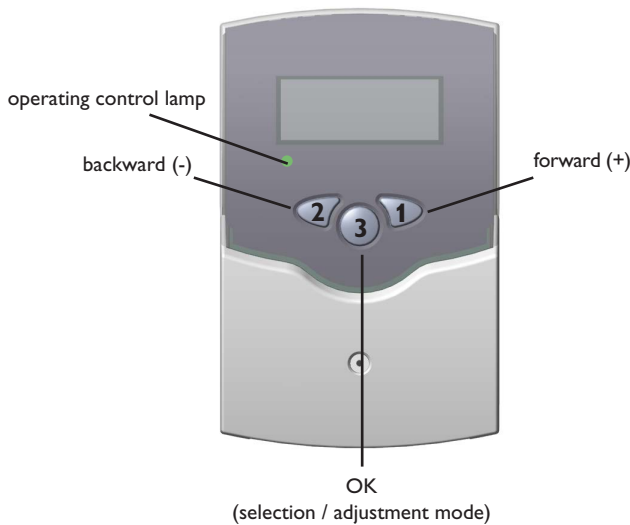

The controller is operated via three push buttons below the display.

Button 1 is used for scrolling forward through the indication menu or to increase the adjustment values. **Button 2** is used for scrolling backward and reducing values. **Button 3** is used for selecting channels and confirming adjustments.

During normal operation, only the display channels are shown.

→ Scroll through the display channels by pressing buttons 1 and 2

Accessing the adjustment channels:

→ Scroll down in the display menu and press button 1 for approx. 2 seconds after you have reached the last display item.

When an **adjustment value** is shown on the display, **SET** is indicated to the right of the channel name.

→ Press button 3 in order to access the adjustment mode **SET** starts flashing.

→ Adjust the value using buttons 1 and 2

→ Briefly press button 3, **SET** permanently appears, the adjusted value will be saved.

2.2 System monitoring display

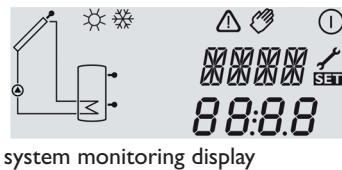

system monitoring display

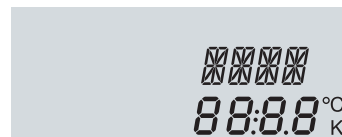

channel display



tool bar

The system monitoring display consists of three blocks: **channel display**, **tool bar** and **system screen**.

The **channel display** consists of 2 lines. The upper line is an alpha-numeric 16-segment display (text display) for displaying channel names and menu items. In the lower 7-segment display, the channel values and the adjustment parameters are displayed.

Temperatures are either indicated in °F or °C, whereas temperature differences are indicated in K or °Ra respectively.

The additional symbols of the **tool bar** indicate the current system status.

Status	standard	flashing
relay 1 active	ⓘ	
maximum tank temperature exceeded	☀	
tank emergency shutdown active		⚠ + ☀
collector emergency shutdown active		⚠
collector cooling active	ⓘ	☀
system cooling active	ⓘ	☀
tank cooling active	ⓘ + ☀	
holiday cooling function activated	☀	⚠
holiday cooling function active	ⓘ + ☀	⚠
collector minimum limitation active		❄
antifreeze function activated	❄	
antifreeze function active	ⓘ	❄
manual operation relay 1 ON	☞ + ⓘ	⚠
manual operation relay 1 OFF	☞	⚠
sensor defective	🔧	⚠

System screen



system screen

The system screen shows the solar system. It consists of several system component symbols, which are – depending on the current status of the system – either flashing or permanently shown.

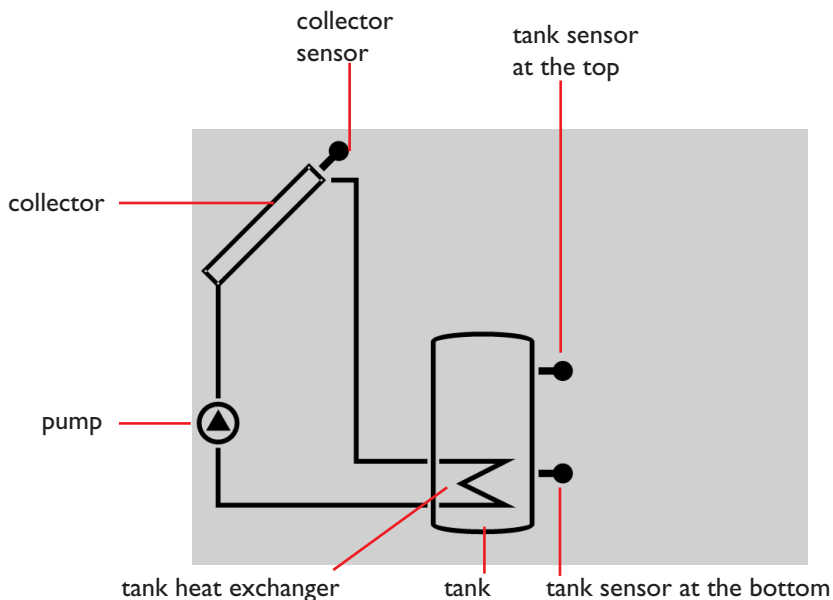

Collector
with collector sensor



Temperature sensor



Tank
with heat exchanger



Pump

2.3 Flashing codes

System screen flashing codes

- Pump is flashing when the relay is active
- Sensor symbols are flashing if the corresponding sensor display channel is selected.
- Sensors are flashing quickly in the case of a sensor fault.

LED flashing codes

- | | |
|---------------------|-------------------------------------|
| green: | everything OK |
| red/green flashing: | initialization phase |
| red flashing: | manual operation |
| | sensor fault |
| | (sensor symbol is flashing quickly) |

3. Commissioning



The three push buttons of the BS/2 controller

→ Establish the power supply

During a short initialization phase, the operating control lamp flashes red and green.

When the controller is commissioned for the first time or after a reset, it will run a commissioning menu. The commissioning menu leads the user through the most important adjustment channels needed for operating the system.

Operating the commissioning menu:

→ Enter the channel by pressing button 3

The **SET** symbol flashes.

→ Adjust the value by pressing buttons 1 and 2

→ Save the adjustment by pressing button 3 again

The **SET** symbol stops flashing.

→ Press button 1 or 2 to switch to the next or previous channel

The commissioning menu consists of the following 4 channels:

LANG:

Language selection
Selection: dE, En, Fr
Factory setting: En



1. Language

→ Adjust the desired menu language in this channel

- dE : German
- En : English
- Fr : French

UNIT:

Temperature unit selection
Selection: °F, °C
Factory setting: °C



2. Unit

→ Adjust the unit in which temperatures and temperature differences shall be displayed

S MX:

Maximum tank temp.

Adjustment range:

40 ... 200 °F [4 ... 95 °C]

in steps of 2 °F [1 °C]

Factory setting: 140 °F [60 °C]

**3. Maximum tank temperature**

→ Adjust the desired maximum tank temperature

**Note:**

The controller is also equipped with a non-adjustable emergency shutdown function, which will shut the system down if the tank reaches 200 °F [95 °C].

nMN:

Pump speed control

Adjustment range:

30 ... 100 %

in steps of 5 %

Factory setting: 30 %

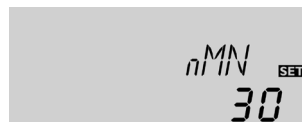
**4. Minimum pump speed**

→ Adjust a minimum speed for the pump

**Note:**

If a load which is not speed-controlled is used, the value must be set to 100 %.

Confirmation enquiry**Completing the commissioning menu**

After the last channel of the commissioning menu has been adjusted and confirmed, the controller asks for confirmation of the adjustments.

→ To confirm the adjustments made in the commissioning menu, press button 3

Now the controller is ready for operation with typical settings to suit the selected system layout.

The settings made in the commissioning menu can be changed later on in the corresponding adjustment channels. Additional functions and options can of course be individually adjusted as well (see chap. 4.2).

4. Channel overview

4.1 Display channels

Indication of drainback time periods

Initialization

INIT:
ODB initialization active

INIT
60

Indicates the time adjusted in **tD_{TO}**, running backwards.

Filling time

FLL:
ODB filling time active

FLL
05:00

Indicates the time adjusted in **tF_{LL}**, running backwards.

Stabilization

STAB:
Stabilization

STAB
02:00

Indicates the time adjusted in **tS_{TB}**, running backwards.

Indication of collector temperature

COL:
Collector temperature
Display range: -40...+500 °F
[-40...+260 °C]

COL
185.0

Indicates the current collector temperature.

Indication of tank temperatures

TST:
Tank temperatures
Display range: -40...+500 °F
[-40...+260 °C]

TST
140.0

Indicates the current tank temperature.

Indication of sensors 3 and 4

S3, S4:
Sensor temperatures
Display range: -40...+500 °F
[-40...+260 °C]

S3
87.5

Indicates the current temperature of the corresponding additional sensor (without control function).

- S3 : temperature sensor 3
- S4 : temperature sensor 4

Indication of return temperature

TR:
Return temperature
Display range: -40...+500 °F
[-40...+260 °C]

TR
136.4

If energy metering is active, the temperature at sensor 4 is indicated as TR.



Note:

The displayed values and adjustment channels depend on which options and functions have been selected. Only values and adjustment channels available for the individual settings selected will appear in the menu.



Note:

S3 and S4 will only be indicated if the temperature sensors are connected.

Indication of current pump speed**n %:**Current pump speed
Display range: 30...100 %**kWh/MWh:** Heat quantity
in kWh / MWh
Display channel

Indicates the current pump speed of the solar pump.

Indicates the energy gained in heat quantity – only available if energy metering (OHQM) is activated.

The flow rate as well as the reference sensors S1 (flow) and S4 (return) are used for calculating the heat quantity supplied. It is shown in kWh in the channel **kWh** and in MWh in the channel **MWh**. The overall heat quantity results from the sum of both values.The accumulated heat quantity can be set back to 0. As soon as one of the display channels of the heat quantity is selected, the **SET** symbol is permanently shown on the display.

→ Press button 3 for about 2 seconds in order to access the RESET mode of the counter.

The display symbol **SET** will flash and the heat quantity value will be set to 0.

→ Confirm the reset with button 3 in order to finish the reset.

In order to interrupt the RESET-process, do not press a button for about five seconds. The display returns to the display mode.

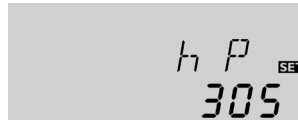
Operating hours counter**h P:**Operating hours counter
Display channelThe operating hours counter accumulates the solar operating hours of the relay (**h P**). Full hours are displayed.The accumulated operating hours can be set back to 0. As soon as one operating hours channel is selected, the symbol **SET** is displayed.

→ In order to access the RESET-mode of the counter, press button 3 for approx. 2 seconds.

The display symbol **SET** will flash and the operating hours will be set to 0.

→ Confirm the reset with button 3 in order to finish the reset.

In order to interrupt the RESET-process, do not press a button for about five seconds. The display returns to the display mode.

4.2 Adjustment channels

ΔT-regulation

DT O:

Switch-on temperature diff.
Adjustment range: 2.0 ... 40.0 °Ra
[1.0 ... 20.0 K]
in steps of 1 °Ra [0.5 K]
Factory setting: 12.0 °Ra
[6.0 K]

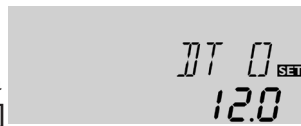

DT F:

Switch-off temperature diff.
Adjustment range: 1.0 ... 39.0 °Ra
[0.5 ... 19.5 K]
in steps of 1 °Ra [0.5 K]
Factory setting: 8.0 °Ra
[4.0 K]

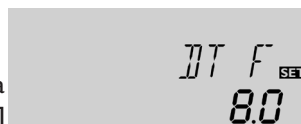

Pump speed control

DT S:

Nominal temperature difference
Adjustment range: 3.0 ... 60.0 °Ra
[1.5 ... 30.0 K]
in steps of 1 °Ra [0.5 K]
Factory setting: 20.0 °Ra
[10.0 K]

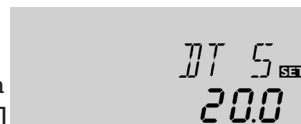

RIS:

Rise
Adjustment range:
2 ... 40 °Ra [1 ... 20 K]
in steps of 2 °Ra [1 K]
Factory setting: 4 °Ra [2 K]



Minimum pump speed

nMN:

Pump speed control
Adjustment range:
30 ... 100 %
in steps of 5 %
Factory setting: 30 %
if ODB is activated: 50 %

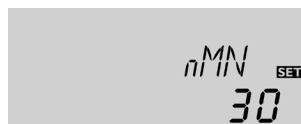

The controller works as a standard differential controller. If the switch-on difference is reached, the pump is activated. When the temperature difference falls below the adjusted switch-off temperature difference, the relay switches off.



Note:

The switch-on temperature difference must be at least 1 °Ra [0.5 K] higher than the switch-off temperature difference.



Note:

When the drainback option **ODB** is activated, the temperature differences **DT O**, **DT F** and **DT S** are set to a fixed adjustment:

DT O = 20 °Ra [10 K]
DT F = 8 °Ra [4 K]
DT S = 30 °Ra [15 K]

Previous adjustments made in these channels will be overridden and may have to be entered again if **ODB** is deactivated later on.



Note:

For pump speed control, the operation mode of relay 1 must be set to Auto (adjustment channel **MAN**)

When the switch-on temperature difference is reached, the pump is activated at full speed for 10 seconds. Then, the speed is reduced to the minimum pump speed value (factory setting = 30 %).

If the temperature difference reaches the adjusted nominal temperature difference, the pump speed increases by one step (10 %). If the difference increases by the adjustable rise value, the pump speed increases by 10 % respectively until the maximum pump speed of 100 % is reached. The response of the controller can be adapted via the parameter "Rise".



Note:

The nominal temperature difference must be at least 1 °Ra [0.5 K] higher than the switch-on temperature difference.

A relative minimum pump speed can be allocated to the output R1 via the adjustment channel **nMN**.



Note:

When a load which is not speed-controlled is used, the value must be set to 100 % in order to deactivate pump speed control.

Maximum tank temperature**SMX:**

Maximum tank temp.

Adjustment range:

40 ... 200 °F [4 ... 95 °C]

in steps of 2 °F [1 °C]

Factory setting: 140 °F [60 °C]



Once the adjusted maximum temperature is exceeded, the solar pump is switched off and further loading of the tank is prevented to reduce scald risk or system damage. A fixed hysteresis of 4 °Ra [2 K] is set for the maximum tank temperature.

When the temperature at sensor 2 exceeds the adjusted maximum tank temperature, the  symbol is shown on the display.

**Note:**

If the collector cooling or the system cooling function is activated, the adjusted tank temperature may be overridden. In order to prevent system damage, the controller is also equipped with a non-adjustable emergency shutdown if the tank reaches 200 °F [95 °C].

Tank emergency shutdown option**OSEM:**

Tank emergency shutdown option

Adjustment range: OFF/ON

Factory setting: OFF

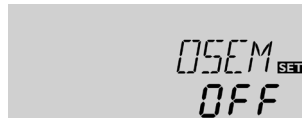

This option is used for activating the integrated tank emergency shutdown for an upper tank sensor. If the temperature at the reference sensor (S3) exceeds 200 °F [95 °C], the tank will be blocked and loading will be stopped until the temperature falls below 190 °F [90 °C].

**Collector temperature limitation
Emergency shutdown of the collector****EM:**

Collector temperature limitation

Adjustment range:

170 ... 390 °F

[80 ... 200 °C]

in steps of 2 °F [1 °C]

Factory setting:

270 °F [130 °C]

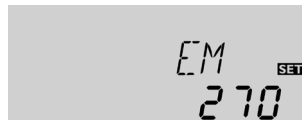

If the adjusted collector emergency shutdown temperature **EM** is exceeded, the controller switches off the solar pump (R1) in order to protect the system against overheating (collector emergency shutdown). A hysteresis of 20 °Ra [10 K] is set for the collector temperature limitation. While the collector is in emergency shutdown,  (flashing) is shown on the display.

**Note:**

If the drainback option **ODB** is activated, the adjustment range of **EM** is changed to 170 ... 250 °F [80 ... 120 °C]. The factory setting in that case is 200 °F [95 °C].

<p>WARNING!</p> 	<p>Danger of injury and system damage through pressure surges!</p> <p>If water is used as a heat transfer medium in a pressure-less system, the water will start boiling at 212 °F [100 °C].</p> <p>→ If a pressure-less drainback system is used with water as a heat transfer medium, do not adjust the collector temperature limitation EM to more than 200 °F [95 °C]!</p>
---	--

Cooling functions

Below, the three cooling functions – collector cooling, system cooling and tank cooling – are described in detail. The following note is valid for all three cooling functions:



Note:

The cooling functions will not become active as long as solar loading is possible.

Collector cooling function

OCC:

Option collector cooling
Adjustment range: OFF/ON
Factory setting: OFF

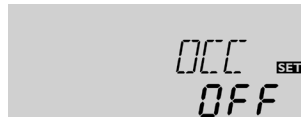

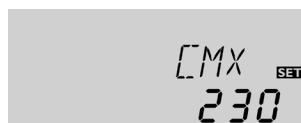

CMX:

Maximum collector temp.
Adjustment range:
150...320 °F
[70 ... 160 °C]
in steps of 1 °F [1 °C]
Factory setting:
230 °F [110 °C]



When the collector cooling function is activated, the controller aims to keep the collector at an operational temperature. When the adjusted maximum tank temperature is reached, solar loading stops. If the collector temperature increases to the adjusted maximum collector temperature, the solar pump is activated until the collector temperature falls at least 10 °Ra [5 K] below the maximum collector temperature. The tank temperature may increase (subordinate active maximum tank temperature), but only up to 200°F [95 °C] (emergency shutdown of the tank).

If the collector cooling function is active,  and  (flashing) is shown on the display.



Note:

This function will only be available if the system cooling function (**OSYC**) is deactivated.

System cooling function

OSYC:

Option system cooling
Adjustment range: OFF/ON
Factory setting: OFF

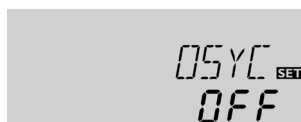

DTCO:

Switch-on temperature diff.
Adjustment range:
2.0 ... 60.0 °Ra
[1.0 ... 30.0 K]
in steps of 1 °Ra [0.5 K]
Factory setting:
40.0 °Ra [20.0 K]



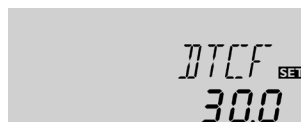

DTCF:

Switch-off temperature diff.
Adjustment range:
1.0 ... 59.0 °Ra
[0.5 ... 29.5 K]
in steps of 1 °Ra [0.5 K]
Factory setting:
30.0 °Ra [15.0 K]



When the system cooling function is activated, the controller aims to keep the solar system operational for a longer time. The function overrides the maximum tank temperature to provide thermal relief of the collector field and the heat transfer fluid on hot days.

If the tank temperature is higher than the maximum tank temperature **S MX** and the switch-on temperature difference **DTCO** is reached, the solar system remains activated. Solar loading is continued until either the tank temperature reaches 200 °F [95 °C] (emergency shutdown of the tank), the temperature difference falls below the adjusted value **DTCF** or the collector emergency shutdown temperature **EM** is reached.

If the system cooling function is active,  and  (flashing) is shown on the display.



Note:

This function will only be available if the collector cooling function (**OCC**) is deactivated.

Tank cooling function**OSTC:**

Tank cooling option
Adjustment range: OFF/ON
Factory setting: OFF

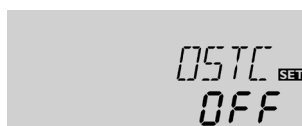
**OHOL:**

Holiday cooling option
Adjustment range: OFF/ON
Factory setting: OFF

**THOL:**

Holiday cooling temperature
Adjustment range:
70 ... 175 °F
[20 ... 80 °C]
in steps of 1 °F [1 °C]
Factory setting:
110 °F [40 °C]

**Collector minimum limitation option****OCN:**

Collector minimum limitation
Adjustment range: OFF / ON
Factory setting: OFF

**CMN:**

Collector minimum temp.
Adjustment range:
50.0 ... 190.0 °F
[10.0 ... 90.0 °C]
in steps of 1.0 °F [0.5 °C]
Factory setting:
50.0 °F [10.0 °C]

**Antifreeze option****OCF:**

Antifreeze function
Adjustment range: OFF / ON
Factory setting: OFF

**CFR:**

Antifreeze temperature
Adjustment range:
-40.0 ... +50.0 °F
[-40.0 ... +10.0 °C]
in steps of 1 °F [0.5 °C]
Factory setting:
40.0 °F [4.0 °C]



When the tank cooling function is activated, the controller aims to cool down the tank during the night in order to prepare it for solar loading on the following day.

If the adjusted maximum tank temperature **S MX** is exceeded and the collector temperature falls below the tank temperature, the system will be reactivated in order to cool down the tank. Cooling will continue until the tank temperature has fallen below the adjusted maximum tank temperature **S MX** again. A fixed hysteresis of 4 °Ra [2 K] is set for this function.

Reference threshold temperature differences for the tank cooling function are **DT O** and **DT F**.

If no DHW consumption is expected for a longer period of time, the additional holiday cooling option **OHOL** can be activated in order to extend the tank cooling function. The adjustable temperature **THOL** then replaces the maximum tank temperature **S MX** as a switch-off temperature for the tank cooling function.

When the holiday cooling function is activated, ☀ and ⚠ (flashing) are shown on the display.

While the holiday cooling function is active, ⓪, ☀ and ⚠ (flashing) are shown on the display.

If the collector minimum limitation option is activated, the pump (R1) is only switched on if the adjustable collector minimum temperature is exceeded. The minimum temperature prevents the pump from being switched on too often at low collector temperatures. A fixed hysteresis of 10 °Ra [5 °K] is set for this function.

If the collector minimum limitation is active, ❄ (flashing) is shown on the display.

**Note:**

If **OSTC** or **OCF** is active, the collector minimum function will be overridden. In that case, the collector temperature may fall below **CMN**.

The antifreeze function activates the loading circuit between the collector and the tank when the temperature falls below the adjusted antifreeze temperature. This will protect the fluid against freezing or coagulating. If the adjusted antifreeze temperature is exceeded by 2 °Ra [1 K], the loading circuit will be deactivated.

When the antifreeze function is activated, ❄ is shown on the display. If the antifreeze function is active, ⓪ and ❄ (flashing) are shown on the display.

**Note:**

Since this function uses the limited heat quantity of the tank, the antifreeze function should be used in regions with few days of temperatures around the freezing point.

The antifreeze function will be suppressed if the tank temperature falls below 40 °F [5 °C] in order to protect the tank from frost damage.

Energy metering

OHQM: Energy metering
Adjustment range: OFF/ON
Factory setting: OFF



FMAX: Flow rate in l/min
Adjustment range: 0.5 ... 100.0
in steps of 0.5
Factory setting: 6.0



MEDT: Heat transfer fluid
Adjustment range: 0...3
Factory setting: 1



MED%: Antifreeze ratio
in Vol-% (MED% is hidden
when MEDT 0 or 3 is used.)
Adjustment range: 20 ... 70 %
in steps of 1 %
Factory setting: 45 %



If OHQM is activated, the heat quantity gained can be calculated and displayed. Energy metering is possible if a flowmeter is used. To enable energy metering, proceed as follows:

- Read the flow rate (l/min) from the flowmeter at maximum pump speed and adjust it in the **FMAX** channel
- Adjust the heat transfer fluid and the concentration of the antifreeze in the channels **MEDT** and **MED%**.

Heat transfer fluid:

- 0 : Water
- 1 : Propylene glycol
- 2 : Ethylene glycol
- 3 : Tyfocor® LS / G-LS

Drainback option**ODB:**

Drainback option

Adjustment range: OFF/ON

Factory setting: OFF

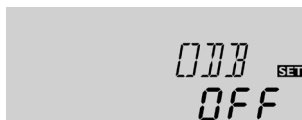
**Note:**

A drainback system layout requires additional components such as a holding tank. The drainback option should only be activated if all components required are properly installed.

A drainback system permits the heat transfer fluid to drain back into the holding tank when solar energy is not collected. The drainback option will initiate the filling of the system when solar loading begins.

If the drainback option **ODB** is activated, the pump will operate at 100 % speed for the adjusted filling time **tFLL** in order to fill the system with fluid from the holding tank. After **tFLL**, pump speed will go down to the adjusted minimum pump speed **nMn**. The switch-off conditions will then be ignored for the stabilization time **tSTB** in order to avoid the system from shutting down prematurely.

If the function is activated, the menu items described in the following (**tDTo**, **tFLL** and **tSTB**) have to be adjusted:

**Note:**

When the drainback option **ODB** is activated, the cooling functions **OCC**, **OSYC** and **OSTC** as well as the antifreeze function **OCF** are not available.

If **OCC**, **OSYC**, **OSTC** or **OCF** have already been activated before, they will be deactivated again as soon as **ODB** is activated. They will remain deactivated, even if **ODB** is deactivated later on.

**Note:**

When the drainback option **ODB** is activated, the temperature differences **DT O**, **DT F** and **DT S** as well as the minimum speed value **nMn** are set to a fixed adjustment. Additionally, the adjustment range and the factory setting of the collector emergency shutdown temperature **EM** changes (see the corresponding channel descriptions for further information).

Previous adjustments made in these channels will be overridden and have to be entered again if **ODB** is deactivated later on.

Time period - switch-on conditions**tDTo:**

Time period -

switch-on conditions

Adjustment range: 1 ... 100 s

in steps of 1 s

Factory setting: 60 s

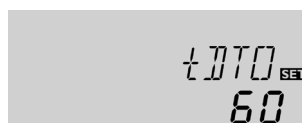
**Filling time****tFLL:**

Filling time

Adjustment range:

1.0 ... 30.0 min

in steps of 0.5 min

Factory setting: 5.0 min

**Stabilization****tSTB:**

Stabilization

Adjustment range:

1.0 ... 15.0 min

in steps of 0.5 min

Factory setting: 2.0 min

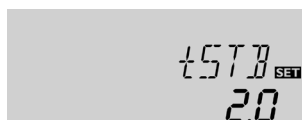

The parameter **tDTo** is used for adjusting the time period during which the switch-on condition **DT O** must be permanently fulfilled.

The filling time can be adjusted using the parameter **tFLL**. During this period, the pump runs at 100 % speed.

The parameter **tSTB** is used for adjusting the time period during which the switch-off condition **DT F** will be ignored after the filling time has ended.

Operating mode**MAN:**

Operating mode
Adjustment range: OFF, Auto, ON
Factory setting: Auto



For control and service work, the operating mode of the controller can be manually adjusted. For this purpose, select the adjustment value **MAN** in which the following adjustments can be made:

Operating mode
OFF : relay off (flashing) +
Auto : relay in automatic operation
ON : relay on (flashing) + +

**Note:**

Always adjust the operating mode back to “Auto” when the control and service work is completed. Normal operation is not possible in manual mode.

HE pump control**ADA1:**

HE pump control
Adjustment range: ON/OFF
Factory setting: OFF

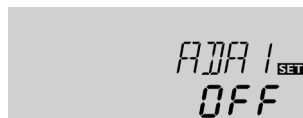

This option is used for controlling a high-efficiency pump via a VBus®/PWM adaptor. The power supply of the pump takes place via the semiconductor relay (R1). For pump speed control with activated ADA1 option, the relay is switched on or off (no pulse packets). Temperature dependent speed information is transmitted via the VBus®. The relay will remain deactivated for 1 hour after its switch-off conditions have been fulfilled (pump protection).

Language**LANG:**

Language selection
Selection: dE, En, Fr
Factory setting: En



The menu language can be adjusted in this channel.

- dE : German
- En : English
- Fr : French

Unit**UNIT:**

Temperature unit selection
Selection: °F, °C
Factory setting: °C



In this adjustment channel, the display unit for temperatures and temperature differences can be chosen. The unit can be switched between °C / K and °F / °Ra during operation. Temperatures and temperature differences in °F and °Ra are displayed without units. If the indication is set to °C, the units are displayed with the values.

Reset**RESE**

Reset function



By using the reset function, all adjustments will be set back to the factory settings.

→ To initiate a reset, press button 3

Any previous adjustments will be lost. Therefore, initiating the reset function is always followed by a security enquiry.

Only confirm the security enquiry if you are sure that you wish to reset all adjustments to the factory settings!

→ To confirm the security enquiry, press button 3

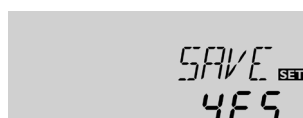
Security enquiry:**Note:**

Whenever a reset has been completed, the controller runs the commissioning menu again (see chap. 3).

5. Troubleshooting

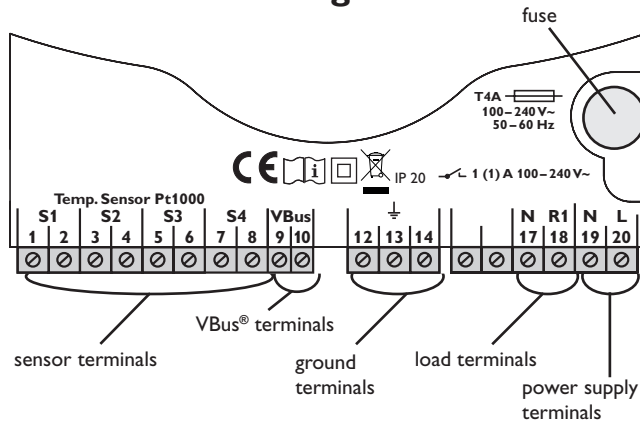

In the case of an error, a message is shown on the display of the controller:

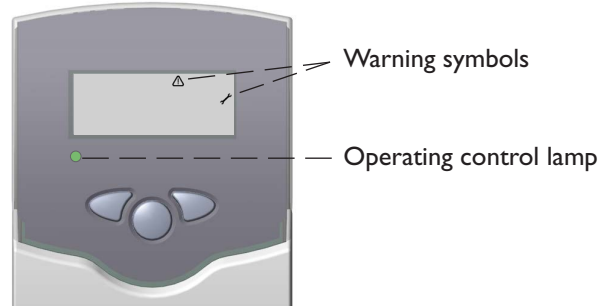

Operating control lamp flashes red. On the display the symbols and appear.

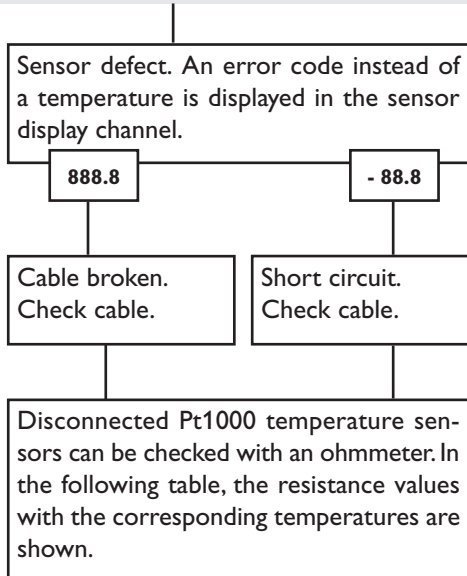

°C	°F	Ω	°C	°F	Ω
-10	14	961	55	131	1213
-5	23	980	60	140	1232
0	32	1000	65	149	1252
5	41	1019	70	158	1271
10	50	1039	75	167	1290
15	59	1058	80	176	1309
20	68	1078	85	185	1328
25	77	1097	90	194	1347
30	86	1117	95	203	1366
35	95	1136	100	212	1385
40	104	1155	105	221	1404
45	113	1175	110	230	1423
50	122	1194	115	239	1442

Resistance values of the Pt1000-sensors

Operating control lamp off.

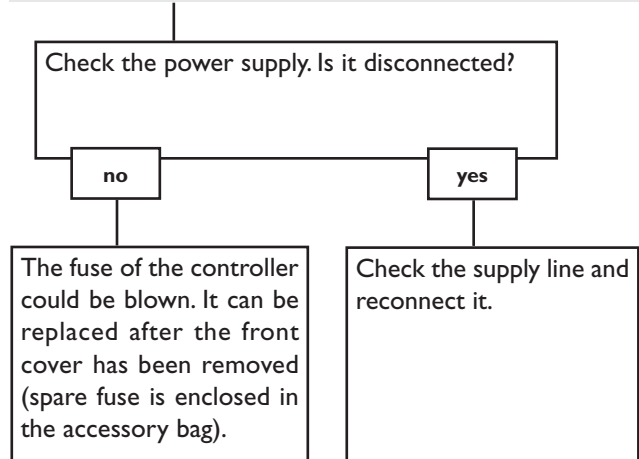

5.1 Various

Pump is overheated, but no heat transfer from the collector to the tank, flow and return have the same temperature; perhaps also air / gas bubbles in the lines.

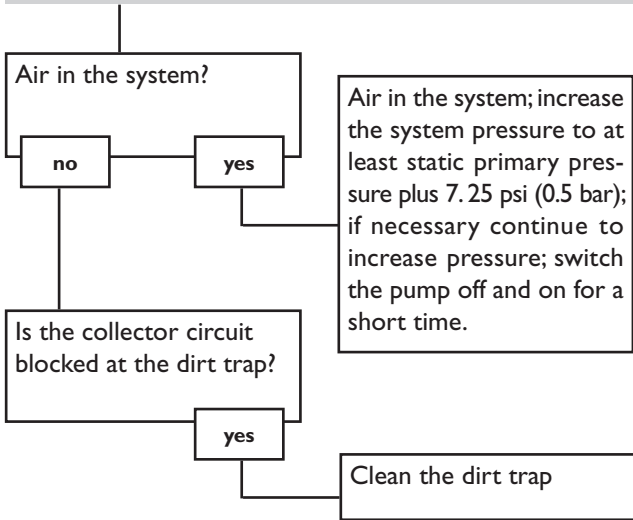

Pump starts for a short moment, switches off, switches on again, etc.

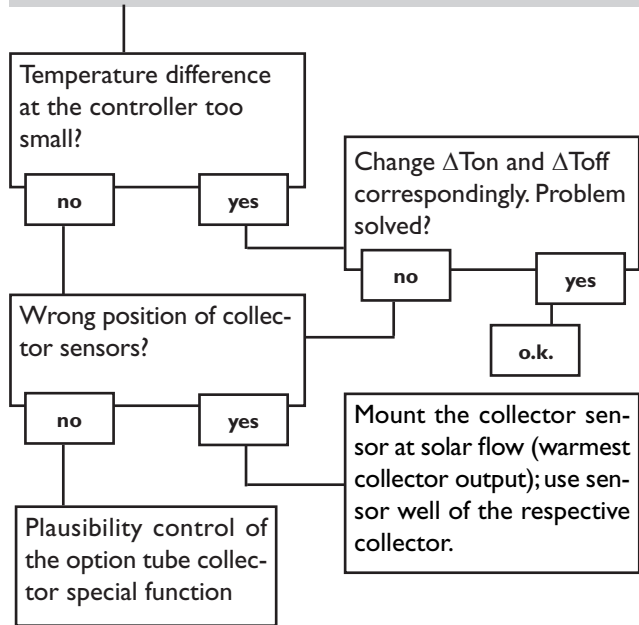

Pump starts up very late

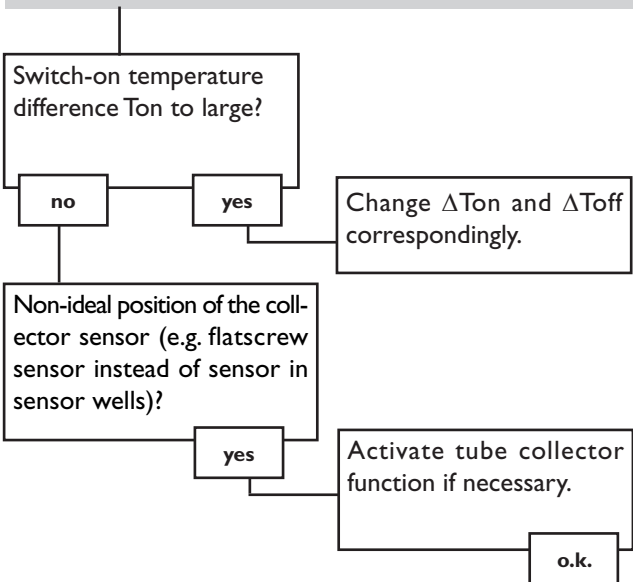

The temperature difference between tank and collector increases enormously during operation; the collector circuit cannot dissipate the heat.

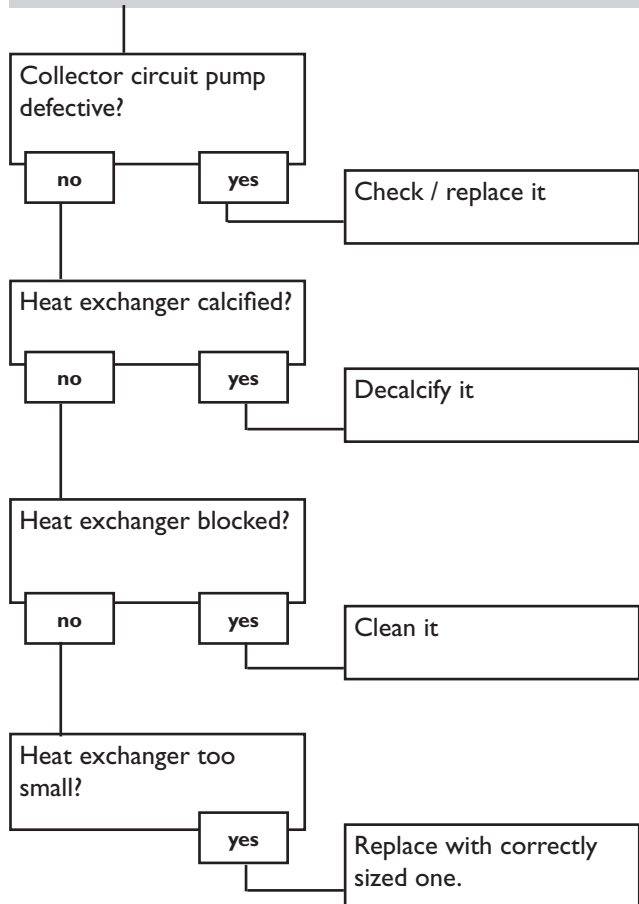

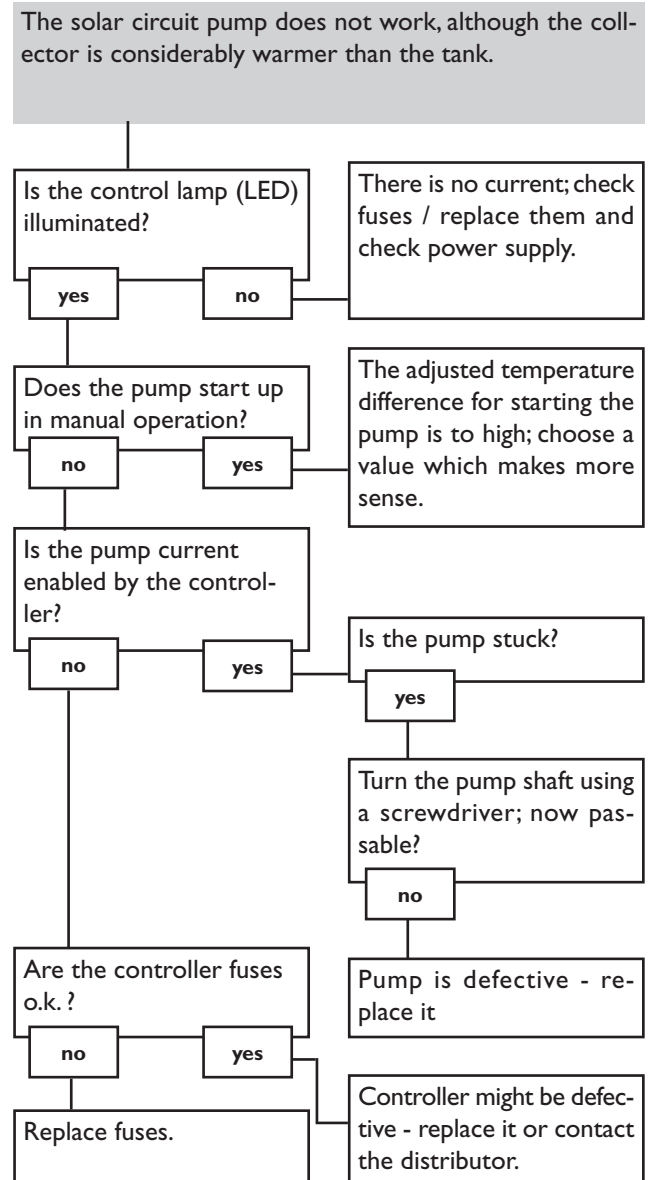
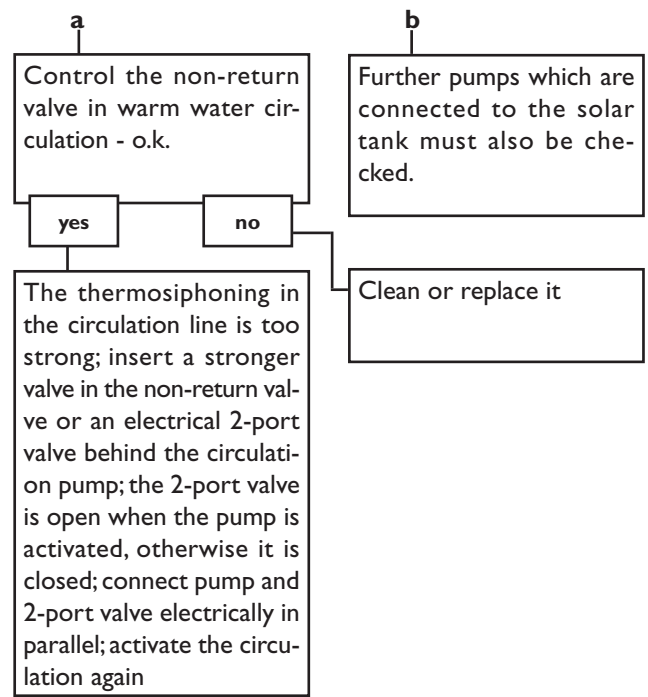
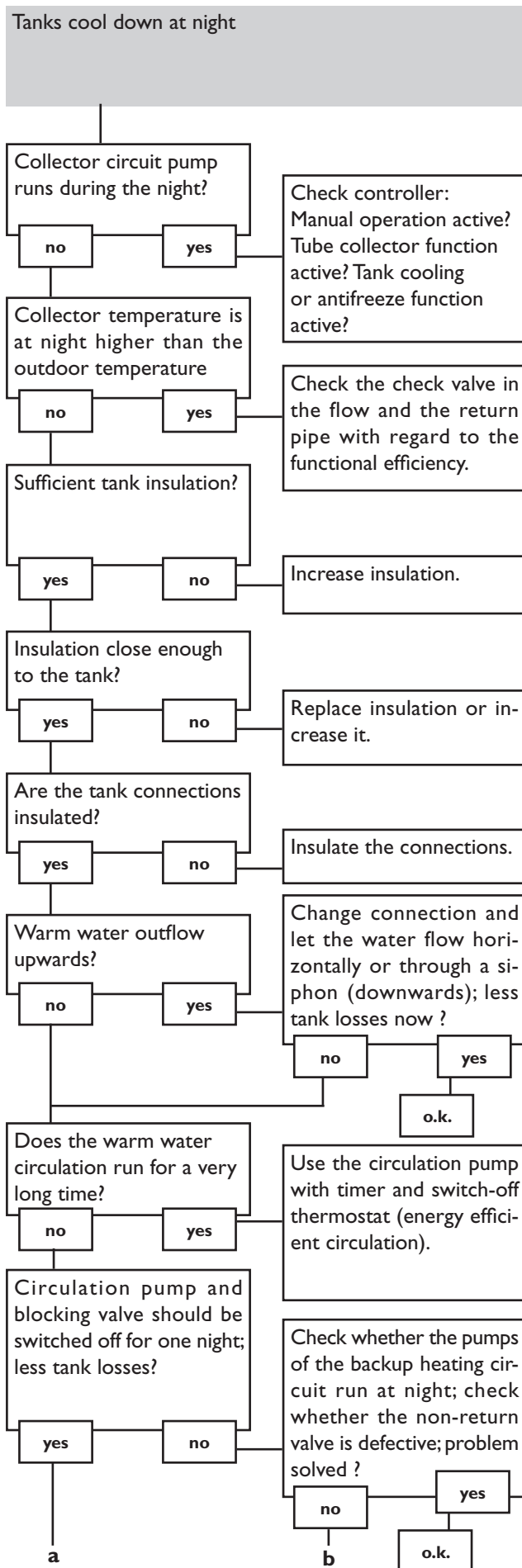

6. Accessories

Sensors

Our product range includes high-precision platinum temperature sensors, flatscrew sensors, outdoor temperature sensors, indoor temperature sensors, cylindrical clip-on sensors, also as complete sensors with immersion sleeve.

For more information, see our catalogue and price list.



Overvoltage protection device

In order to avoid overvoltage damage at collector sensors (e.g. caused by local lightning storms), we recommend the overvoltage protection RESOL SP10.

RESOL SP10

Article no.: **180 110 70**



Smart Display SD3

The RESOL Smart Display is designed for simple connection to RESOL controllers with RESOLVBus®. It is used for visualizing data issued by the controller: collector temperature, storage temperature and energy yield of the solar thermal system. The use of high-efficient LEDs and filter glass assures a high optical brilliance and good readability even in poor visibility conditions and from a larger distance. An additional power supply is not required.

RESOL SD3 (unit °C)

Article no.: **180 004 90**

RESOL SD3 (unit °F)

Article no.: **180 007 77**



Large Display GA3

The RESOL Large Display GA3 is designed for simple connection to RESOL controllers via the RESOLVBus®. It is used for visualizing the data issued by the controller: collector and tank temperature as well as heat quantity produced in the solar system.

The use of high-efficient LEDs and antireflective filter glass assures a high optical brilliance and good readability - even in poor lighting conditions and at a larger distance.

RESOL GA3 (unit °C)

Article no.: **180 006 50**

RESOL GA3 (unit °F)

Article no.: **180 007 87**



DL2 Datalogger

This additional module enables the acquisition and storage of large amounts of data (such as measuring and balance values of the solar system) over a long period of time. The DL2 can be configured and read-out with a standard internet browser via its integrated web interface. For transmission of the data stored in the internal memory of the DL2 to a PC, an SD card can be used.

The DL2 is appropriate for all controllers with RESOL VBus®. It can be connected directly to a PC or router for remote access and thus enables comfortable system monitoring for yield monitoring or for diagnostics of faults.

RESOL DL2Article no.: **180 007 10****VBus® / USB interface adaptor**

The new VBus® / USB interface adaptor is the interface between the controller and a personal computer. With its standard mini-USB port it enables a fast transmission of system data via the VBus® for processing, visualizing and archiving. A full version of the RESOL ServiceCenter software is included.

RESOL VBus® / USB interface adaptorArticle no.: **180 008 50****VBus® / LAN interface adaptor**

The VBus® / LAN interface adaptor is designed for the direct connection of the controller to a PC network or router. It enables easy access to the controller via the local network of the owner. Thus, controller access and data charting can be effected from every workstation of the network. A full version of the RESOL ServiceCenter software is included.

RESOL VBus® / LAN interface adaptorArticle no.: **180 008 80****VBus® / PWM interface adaptor**

The VBus® / PWM interface adaptor is used for the speed control of a pump via a PWM or 0-10V signal. Via the VBus®, the adaptor receives information from the controller about the necessary pump speed. The speed is converted into a PWM or direct voltage signal and put out to the corresponding terminals.

RESOL VBus® / PWM interface adaptorArticle no.: **180 008 60****AM1 Alarm module**

The AM1 alarm module is designed to signal system failures. It is to be connected to the VBus® of the controller and issues an optical signal via a red LED if a failure has occurred. The AM1 also has a dry contact relay output, which can e. g. be connected to a building management system (BMS). Thus, a collective error message can be issued in the case of a system failure.

RESOL AM1 Alarm moduleArticle no.: **180 008 70**

Notes

Notes

Distributed by:

RESOL - Elektronische Regelungen GmbH

Heiskampstraße 10
45527 Hattingen / Germany
Tel.: +49 (0) 23 24 / 96 48 - 0
Fax: +49 (0) 23 24 / 96 48 - 755
www.resol.com
info@resol.com

Important notice:

The texts and drawings in this manual are correct to the best of our knowledge. As faults can never be excluded, please note: Your own calculations and plans, under consideration of the current standards should only be basis for your projects. We do not offer a guarantee for the completeness of the drawings and texts of this manual - they only represent some examples. They can only be used at your own risk. No liability is assumed for incorrect, incomplete or false information and / or any resulting damages.

Please note:

The design and the specifications can be changed without prior notice. The illustrations may differ from the original product.

Reprinting / copying

This mounting- and operation manual including all parts is copyrighted. Another use outside the copyright requires the approval of RESOL - Elektronische Regelungen GmbH. This especially applies for copies, translations, micro-films and the storage into electronic systems.
Editor: RESOL - Elektronische Regelungen GmbH